



The city is conducting this public meeting using a hybrid model. The public is welcome to attend tonight's meeting in-person at City Hall (Council Chambers), or virtually by using the meeting access link below-

<https://sumnerwa-gov.zoom.us/j/83345379222>

Phone one-tap: +12532050468,,83345379222# +12532158782,,83345379222# US (Tacoma)

Join via audio: +1 253 205 0468 +1 253 215 8782 US (Tacoma) Webinar ID: 833 4537 9222

## **CALL TO ORDER**

Pledge of Allegiance

Invocation - Pastor Chris Lumsden

Roll Call: Elfers, Evers, Hochstatter, Kenna, Malcolm, Reinke and Wilsey

*The following items are distributed to Councilmembers in advance for study and review, and the recommended actions will be accepted in a single motion. Any item may be removed for further discussion if requested by a Councilmember.*

## **CONSENT AGENDA**

1. Second Amendment to the 2013 YMCA Services Agreement
2. Resolution No. 1751 - Interlocal Agreement with Pierce County Flood Control Zone District
3. Resolution No. 1750 - Stormwater Capacity Grant Acceptance
4. Fryar Ave Trail Project Property Acquisition - Roman 1, LLC
5. Fryar Ave Trail Project Property Acquisition - Liberty Property Development Corp II
6. Fryar Ave Trail Project Property Acquisition - Lewis Landmark, LLC
7. Fryar Ave Trail Project Property Acquisition - Pierce County
8. Valley Avenue Water System Improvements - Construction Contract Award
9. Resolution No. 1749 - WSDOT Updated Right-of-Way Procedures
10. Neighborhood Traffic Calming and Intersection Data Collection - Consultant Contract Award
11. 63rd Street Storm Improvements Project Change Order #2
12. Operations Facility - Puget Sound Energy Gas Easement
13. Heritage Park Remediation - Design Consultant Contract Award
14. Approval of the minutes from the following: April 20, 2026 regular council meeting, April 27th study session, and May 4th and May 11th council budget retreats.

## **PUBLIC HEARING**

## **REGULAR BUSINESS**

1. **Unfinished Business**

- a. Ordinance No. 2966 - Vacation of 63rd Street East and a Portion of State Street
2. **Public Comment (Limit 3 minutes)**  
Members of the community who wish to give public comment are strongly encouraged to attend the meeting via the ZOOM link or by telephone. If you are unable to attend the meeting, please submit your public comment in writing via email to the City Clerk at [Michellec@sumnerwa.gov](mailto:Michellec@sumnerwa.gov) no later than 4:00pm on the day of the meeting. Please contact the City Clerk at 253-299-5590 with any questions.
3. **New Business**
  - a. Appointment to Sumner Lodging Tax Advisory Committee - Crick
  - b. Appointment to the Forestry, Parks & Arts Commission - Thomas
  - c. Appointment to the Forestry, Parks & Arts Commission - Mathews
  - d. Heritage Park Phase 3 & 4 Consultant Contract Amendment
  - e. Ordinance No. 2967 - System Development Charges Calculation
4. **Reports**
  - a. Council
  - b. City Administrator
  - c. Mayor
5. **Executive Session**  
Pursuant to RCW 42.30.110(1)(g), to review the qualifications and performance of appointed employees
6. **Adjournment**

*This meeting is accessible to persons with disabilities. For individuals who may require special accommodations, please contact the City Clerk at (253) 299-5590, 24 hours in advance.*

---

**SUBJECT:** Second Amendment to the 2013 YMCA Services Agreement

**CATEGORY:** Consent

---

**BUDGET IMPACT:**

Expenditure Required: None

Within Budget Allocation: N/A

---

**ATTACHMENTS:**

1. Second Amendment to the 2013 YMCA Services Agreement

**STAFF CONTACT:** Jason Wilson, City Administrator

---

**SUMMARY BACKGROUND:**

Staff is proposing an amendment to the 2013 services agreement to expand the types of services provided by the YMCA. The expanded services are consistent with the type of services the City received from the 2019 services agreement, and benefit more members of our community. These services are provided by the YMCA to the City's residents and visitors in satisfaction and exchange for the land donation provided by the City to the YMCA for the current facility.

---

**COUNCIL COMMITTEE/STUDY SESSION:** Study Session

**MEETING/STUDY SESSION DATE:** 4/27/2026

**COMMITTEE RECOMMENDATION:**

**STAFF RECOMMENDATIONS/MOTION:**

A motion approving amendment No. 2 to the 2013 services agreement with the YMCA of Pierce and Kitsap Counties, and authorizing the Mayor to execute any and all documents necessary to effectuate the amendment, substantially in a form as approved by the City Attorney.

SECOND AMENDMENT  
TO SERVICES AGREEMENT

This SECOND AMENDMENT TO SERVICES AGREEMENT (the “Amendment”) is made and entered into as of May \_\_\_\_, 2026, by and between THE CITY OF SUMNER, WASHINGTON, a Washington municipal corporation (the “City” or “Sumner”), and the YOUNG MEN’S CHRISTIAN ASSOCIATION OF PIERCE AND KITSAP COUNTIES, a Washington non-profit corporation (the “YMCA”). The City and YMCA are referred to in this Agreement individually as a “Party” and, collectively, as the “Parties.” Except as expressly provided herein, capitalized terms in this Amendment have the meanings specified in the 2013 Services Agreement, dated as of May 7, 2013 (“2013 Services Agreement”), and First Amendment dated August 15, 2022, attached hereto.

RECITALS

- A. The Parties entered into the 2013 Services Agreement with a common goal to identify a location for development and operation of a YMCA community center within the City (“Facility”).
- B. In lieu of operating and maintaining its own community related center, the City provided the YMCA with a monetary contribution to the Facility and desired to contract with the YMCA to operate and maintain the Facility and to provide social services, recreational programming, and other services for residents of Sumner.
- C. In consideration of the monetary contribution from the City to the YMCA as more fully set forth in the 2013 Services Agreement, the YMCA is obligated to deliver the agreed services during the term of the 2013 Services Agreement.
- D. After execution of the Agreement, the YMCA experienced, and continues to experience, substantial impacts caused by the Covid-19 worldwide pandemic, which interfered with the YMCA’s ability to timely fulfil the services obligations outlined therein and caused the cost of the project to more than double due to hyperinflation. By no fault of the YMCA, many of the deadlines and services per the Agreement were not met.
- E. The Parties entered into a First Amendment to the 2013 Services Agreement on August 15, 2022.
- F. The YMCA has been providing services pursuant to the 2013 agreement; however, the scope and effectiveness have changed with time.
- G. The Parties desire to amend the terms of the 2013 Services Agreement to ensure that the City receives full and fair consideration for the prior monetary contribution as more particularly set forth herein.

## AGREEMENT

NOW, THEREFORE, for valuable consideration, the receipt and sufficiency of which is hereby acknowledged, Sumner and the YMCA hereby agree as follows:

1. Article 1, Section 1.1 – Services shall be amended to include the additional provisions as follows:

1.1.12 *Family Membership Vouchers*. The YMCA will provide 320 three-month family membership vouchers between January 1, 2025 and the term expiration date including joining fees, for low income and refugee families. Such vouchers shall be distributed by the Sumner Bonney Lake School District Family Center based upon their low income guidelines and relationships with families and may also be distributed by the YMCA membership team based on need.

1.1.13 *Senior Membership Vouchers*. The YMCA will provide 185 Active Older Adult (55+ years old) membership vouchers between January 1, 2025 and the term expiration date including joining fees for low-income seniors. Such vouchers shall be distributed by the Sumner Bonney Lake School District Family Center and Sumner Senior Center. 50% of the vouchers will be distributed to low-income older adults following a sliding scale based on the Federal Poverty Guidelines. Vouchers may also be distributed by the YMCA based on extenuating circumstances, including extraordinary economic challenges i.e., medical expenses, death, layoffs etc.

1.1.14 *Shower Program*. The YMCA will provide shower services for unhoused community members on Monday – Friday from 6-8am. The YMCA will provide a towel and toiletries for each shower guest. The City agrees to collaborate in efforts to communicate and market this service to unhoused community members.

1.1.15 *Bill Heath Sports Complex Management*. The YMCA will schedule, the complex for use by the YMCA, Sumner Bonney Lake School District and outside organizations renting use of the field. Rental fees collected will be remitted to the City no less than quarterly.

2. Article 3, Section 3.1 – Term shall be amended as follows:

Term. The term of this Agreement (“Term”) shall expire on September 14, 2027 (the 12<sup>th</sup> anniversary date of commercial operations), unless earlier terminated pursuant to Section 3.2 of the 2013 Services Agreement, or upon full and complete provision of the value of services contemplated therein, whichever is later.

The Parties agree to meet in 2027 to discuss an ongoing partnership to provide same or similar services, as listed in Article 1, to the Sumner Community.

3. Full Force and Effect. Except as expressly amended and modified hereby, the 2013

Services Agreement is and shall remain in full force and effect, and the terms and provisions of the 2013 Services Agreement are hereby ratified and affirmed in their entirety.

4. Counterparts. This Amendment may be executed in any number of counterparts, each of which shall be deemed to be an original and all of which shall constitute one and the same agreement. This Amendment shall be deemed executed and delivered upon each party's delivery of executed signature pages, which signature pages may be delivered electronically or by facsimile with the same effect as delivery of the originals.

IN WITNESS WHEREOF, the parties hereto have examined and executed this Amendment as of the date first written above.

CITY:

City of Sumner, a Washington State  
municipal corporation

YMCA:

YOUNG MEN'S CHRISTIAN  
ASSOCIATION OF PIERCE AND  
KITSAP COUNTIES, a Washington  
nonprofit corporation

By: \_\_\_\_\_  
Name: Carla S. Bowman  
Title: Mayor

By: \_\_\_\_\_  
Name: Charlie Davis  
Title: CEO

Approved as to Form:

\_\_\_\_\_  
Andrea Marquez  
City Attorney

ATTEST:

\_\_\_\_\_  
Michelle Converse  
City Clerk

---

**SUBJECT:** Resolution No. 1751 - Interlocal Agreement with Pierce County Flood Control Zone District

**CATEGORY:** Consent

---

**BUDGET IMPACT:**

Expenditure Required: None

Within Budget Allocation: N/A

---

**ATTACHMENTS:**

1. Resolution and ILA

**STAFF CONTACT:** Robert Wright, Assistant Engineering Manager

---

**SUMMARY BACKGROUND:**

The Pierce County Flood Control Zone District (FCZD) adopts an annual budget. This budget often includes funding for City projects such as the White River Restoration and the Stewart Road Bridge. The District has been a large funding partner on projects over the years, providing over \$20 Million to the City. In 2025, the district wished to allocate project funding for 2026 through a competitive process. The City applied for, and was awarded \$9.5 Million that was included in the 2026 FCZD budget resolution.

In order to receive these funds, this interlocal agreement replaces one signed in 2018 with updated project descriptions and dollar amounts. The amount of funding each year will vary based on approved budget resolutions.

---

**COUNCIL COMMITTEE/STUDY SESSION:** Public Works Committee

**MEETING/STUDY SESSION DATE:** 4/21/2026

**COMMITTEE RECOMMENDATION:** Do Pass

**STAFF RECOMMENDATIONS/MOTION:**

A motion to adopt Resolution No. 1751, authorizing the Mayor to enter into an interlocal agreement between the City of Sumner and the Pierce County Flood Control Zone District related to District funded projects in a form as approved by the City Attorney.

**RESOLUTION NO. 1751  
CITY OF SUMNER, WASHINGTON**

**A RESOLUTION OF THE CITY COUNCIL OF THE CITY OF SUMNER, WASHINGTON, AUTHORIZING THE MAYOR TO ENTER INTO AN INTERLOCAL AGREEMENT BETWEEN THE CITY OF SUMNER AND THE PIERCE COUNTY FLOOD CONTROL ZONE DISTRICT RELATING TO DISTRICT FUNDED PROJECTS..**

**WHEREAS**, the Pierce County Flood Control Zone District funds projects that address flood concerns and habitat challenges; and

**WHEREAS**, the District’s Resolution No. 2026-4 authorizes construction and acquisition funding for City of Sumner projects on the White River in the amount of up to \$9.5 million dollars in 2026 plus amounts approved in future budget amendments; and

**WHEREAS**, the City Council has determined it to be in the best interest of the City of Sumner to enter into said intergovernmental agreement; and

**WHEREAS**, the City of Sumner is authorized, pursuant to Chapter 39.34 RCW, Interlocal Cooperation Act, to enter into such agreement.

**NOW, THEREFORE, THE CITY COUNCIL OF THE CITY OF SUMNER, WASHINGTON DOES RESOLVE AS FOLLOWS:**

**Section 1. Authorization.** That the City Council hereby approves an Interlocal Agreement between the City of Sumner and the Pierce County Flood Control Zone District for the purpose of funding projects referenced in the attached agreement. The Mayor is authorized to sign the Agreement in substantially the form that is attached.

**Section 2. Corrections by City Clerk or Code Reviser.** Upon approval of the city attorney, the city clerk and the code reviser are authorized to make necessary corrections to this resolution, including but not limited to the correction of clerical errors; or references to other local, state, or federal laws, codes, rules, or regulations.

**Section 3.** The Mayor is hereby authorized to implement such administrative procedures as may be necessary to carry out the directions of this legislation

**Section 4. Effective Date.** This resolution shall take effect and be in force immediately upon passage by City Council.

**ADOPTED AND APPROVED** this \_\_\_\_ day of \_\_\_\_\_, 2026.

\_\_\_\_\_  
Mayor Carla S. Bowman

**ATTEST:**

**APPROVED AS TO FORM:**

\_\_\_\_\_  
Michelle Converse, CMC, City Clerk

\_\_\_\_\_  
City Attorney Andrea Marquez

1  
2  
3  
4  
5  
6  
7  
8  
9  
10  
11  
12  
13  
14  
15  
16  
17  
18  
19  
20  
21  
22  
23  
24  
25  
26  
27  
28  
29  
30  
31  
32  
33  
34  
35  
36  
37  
38  
39  
40  
41  
42  
43  
44  
45

**RESOLUTION NO. 2026-4**

**A Resolution of the Pierce County Flood Control Zone District Relating to District Flood and Stormwater Projects and Approving an Interlocal Agreement Between the District and the City of Sumner for District Funded Projects.**

**Whereas**, the City of Sumner’s long-term vision for addressing the flooding and habit challenges of the Lower White River includes four projects on the Lower Green River; and

**Whereas**, Resolution No. 2025-5, approved by the Pierce County Flood Control Zone District (District) on October 8, 2025, approved funding to be expended in 2026 for four projects in the City of Sumner including the Lower White River, RM 2.5-4.2, 24<sup>th</sup> Street project (SUM-1), the Sumner Pointbar (SUM-2), the Stewart Street Setback (SUM-3), and the Stewart Road Bridge (SUM-4); and

**Whereas**, Resolution No. 2025-5 authorized construction funding for SUM-1 and SUM-4 and land acquisition funding for SUM-2 and SUM-3; and

**Whereas**, the District and the City are authorized to enter into this Agreement pursuant to RCW 39.34.080 and RCW 86.15.080(11); **Now, therefore**,

**BE IT RESOLVED** by the Board of Supervisors of the Pierce County Flood Control Zone District:

Section 1. The Board of Supervisors approves the “Interlocal Agreement Between the Pierce County Flood Control Zone District and the City of Sumner” attached as Exhibit A to this resolution for District Funded Projects.

**ADOPTED** this 8<sup>th</sup> day of April, 2026.

ATTEST:

**PIERCE COUNTY FLOOD CONTROL  
ZONE DISTRICT**  
Pierce County, Washington

  
\_\_\_\_\_  
**Brenna Price**  
Clerk of the Board

  
\_\_\_\_\_  
**Dave Morell**  
Flood Control Zone District Chair

**INTERLOCAL AGREEMENT BETWEEN  
THE PIERCE COUNTY FLOOD CONTROL ZONE DISTRICT AND THE CITY  
OF SUMNER FOR  
FOR DISTRICT GRANT FUNDED PROJECTS**

THIS INTERLOCAL AGREEMENT FOR PIERCE COUNTY FLOOD CONTROL ZONE DISTRICT GRANT FUNDED PROJECTS (“Agreement”) is made and entered into by and between the City of Sumner, a Washington municipal corporation, hereinafter referred to as the “Grantee,” and the Pierce County Flood Control Zone District, a Washington quasi-municipal corporation, hereinafter referred to as the “District.” The District and the Grantee are individually a “Party” and collectively the “Parties.” This Agreement shall be effective upon execution by the Grantee and the District.

**RECITALS**

A. The District’s Board of Supervisors has adopted Resolution No. 2025-5, the District’s 2026 budget resolution, which lists the included Capital Improvement Projects that will be funded by the District in 2026.

B. Through a competitive process, the Grantee was awarded up to \$9.5 million dollars for four projects in the City of Sumner, identified in the 2026 Budget Resolution and further identified and described in **Attachment A**, attached and incorporated herein.

C. The District desires to provide funding for the Projects consistent with the 2026 Budget Resolution and the terms and conditions of this Agreement.

D. Pursuant to Chapter 39.34 RCW and RCW 86.15.080, the Parties desire to enter into this Agreement to establish the terms and conditions of District providing grant funding for the Projects.

**AGREEMENT**

In furtherance of the foregoing and in consideration of the following terms and conditions, the Parties agree as follows:

1. Definitions. In this Agreement, the following terms shall have the following meanings.

1.1 “Board” means the Board of Supervisors of the District.

1.2 “District Administrator” means the Director of the Pierce County Public Works and Utilities Department, or designee.

1.3 “Funds” shall mean the funds authorized for payment by the District to the Grantee for expenditures on the Projects, as set forth in the 2026 Budget Resolution and any subsequent budget resolutions or resolutions approving modifications to funds authorized or authorizing additional funds for the Projects.

1.4 “Projects” collectively means the Lower White River – RM 2.5-4.2 (24<sup>th</sup> Street) project (SUM-1); the Lower White River – Sumner Pointbar project (SUM-2); Lower White River -Stewart Setback project (SUM-3); and the Lower White River – Stewart Road Bridge project (SUM-4), all as further identified and described in **Attachment A**, and as listed in 2026 Budget Resolution.

1.5 “Project” shall mean any individual project included within the defined term “**Projects**.” References in this Agreement to a “Project” mean one of the Projects, as the context requires.

1.6 “2026 Budget Resolution” means District Resolution No. 2025-5.

## 2. Term of Agreement—Termination of Agreement—Survival of Agreement.

2.1 This Agreement shall be effective upon execution by both Parties and shall remain in effect until the earliest of the following: (a) termination pursuant to Section 2.2, (b) termination pursuant to Section 2.3, or (c) termination for particular Projects for lack of funding authorization pursuant to Section 8.

2.2 Either Party may terminate this Agreement for cause by providing written notice of termination to the other Party. Notice by the Grantee shall be provided to the District Administrator, and notice by the District shall be provided to the Public Works Director of the Grantee. For purposes of this section, “For Cause” shall be limited to the following causes: (1) material breach by either party that is not cured within fourteen (14) days of written notice specifying the breach in reasonable detail; (2) misuse of funds that is inconsistent with the approved budget, scope of work of any Project or in violation of applicable law and not cured or refunded within fourteen (14) days of written notice specifying the misuse in reasonable detail; (3) failure to perform any material deliverable and such failure is not cured within fourteen (14) days of written notice specifying the failure in reasonable detail; (4) legal or regulatory non-compliance by either Party who becomes subject to any investigation, enforcement action or legal proceeding that materially impairs its ability to perform its obligations under this agreement; or (5) insolvency by either Party involving all or substantially all of the Party’s assets. For causes (1), (2), or (3) that cannot reasonably be cured within fourteen (14) days, Grantee shall, within that fourteen (14) day period, commence actions reasonably calculated to cure the cause and thereafter diligently pursue such cure to completion; provided, however, that the cause must be fully cured within sixty (60) days after Grantee’s receipt of the notice of termination. .

2.3 This Agreement may be terminated without notice upon mutual written agreement of the Parties

2.4 Any provision of this Agreement that, by its nature, is intended to continue after termination shall survive termination and remain in effect, including without limitation Sections 10, 11, and 12.

2.5 The Parties agree that the Interlocal Agreement Between the Pierce County Flood Control Zone District and the City of Sumner for District Funded Project (Finding Only), executed Grantee on November 6, 2018, and the District on December 19, 2018, is hereby terminated and replaced by this Agreement.

3. Design, Procurement, and Construction—Permits and Approvals—Submission of Documents. The Grantee shall design, procure, and construct the Projects in compliance with all applicable laws, rules, and regulations, and shall obtain and be responsible for all approvals and permits for the Projects. Prior to bidding of each of the Projects, the Grantee shall submit copies of the bid documents, drawings, plans, and specifications for that Project to the District Administrator. Failure to timely submit the required documents for a Project shall not invalidate the bidding of that Project, but shall be a material breach of this Agreement under Section 2.2 and a basis for withholding Funds under Section 7.

4. Project Work and Funding Sources. The descriptions and schedules for the Projects are stated in **Attachment A**. When requested by the District Administrator, the Grantee shall submit further descriptions of the work and schedule information for the Projects, a description of the funding sources for the Projects, and a schedule of the expected receipt of all funds for the Projects.

5. Payment and Use of Funds. The District shall pay Funds to the Grantee only for Projects-related expenses that are consistent with the “Scope of Work for the FCZD Allocation” in **Attachment A**. The District will make payments pursuant to a procedure and schedule developed by the District Administrator, with reasonable requests by the Grantee considered.

6. Funding Limitation. The Parties acknowledge and agree that the District is only responsible up to the amount the District awarded Grantee for each Project. The financial obligations of the District pursuant to this Agreement are limited to payment of the Funds pursuant to this Agreement for each of the Projects. The Funds were awarded based on the estimated cost of the Projects, and the District shall not be responsible or liable for any Project-related expenses or costs in excess of the Funds authorized for a Project, regardless of whether the actual cost of that Project is greater than its estimated cost.

7. Withholding or Denial of Funds. The District reserves the right to withhold or deny payment of Funds for failure of the Grantee to comply with this Agreement, failure of any of the Projects to meet the descriptions and schedules

in **Attachment A** or in the further descriptions and schedules provided pursuant to Section 4, or failure of any of the Projects to conform substantially to the bid documents, drawings, plans, and specifications.. Should any identified failure be remedied by Grantee, District will then release the withheld or denied Funds, subject to the terms of this Agreement including without limitation Section 8.

8. Multi-Year Projects—Funding Duration—Automatic Termination. The Projects are intended to be constructed or completed in two or more budget years; however, the District's obligation to provide Funds for any subsequent budget year is conditioned upon appropriation of Funds by the District for that subsequent budget year. If the District appropriates Funds for subsequent budget years, the appropriated Funds and associated scopes of work will be added to this Agreement through an amendment. If the District approves Funds for a Project in one budget year but fails to approve Funds for that Project in a subsequent budget year, (a) this Agreement shall remain in force for the Project only until the District has paid all Funds appropriated for the Project in the previous budget year (to the extent Grantee submits for reimbursement by March 31 of the subsequent year), and (b) this Agreement shall remain in force for all other Projects that have received an appropriation of Funds for the subsequent budget year. This Agreement shall terminate in full automatically on March 31 of the first budget year in which the District has not authorized any Funds for the Projects.

9. Project-Related Expenses—Reimbursement. The District's budget year ends December 31 of the designated calendar year. In order to be eligible for reimbursement, Project-related expenses must be incurred during a budget year for which the District has appropriated Funds, and Grantee must request reimbursement for the expenses no later than March 31 of the following budget year. The Grantee may, however, submit to the Board, no later than December 1 of a budget year, a written request for an extension of one year in order to incur the expenses of that current budget year, which the District will consider in its sole discretion

10. Reports—Records Retention—Inspections and Audit.

10.1 The Grantee shall prepare and file written reports describing its request for, and expenditure of, the Funds no less than quarterly, or more frequently, as reasonably required by the District Administrator. The Grantee shall prepare and file a final report after final distribution of Funds for each Project, using the progress report form provided by the District Administrator. The Grantee will make a brief presentation to the Board at a regularly scheduled meeting each year this Agreement is in effect.

10.2 The Grantee shall retain all records and documents relating to the Funds for a minimum of seven (7) years after final payment of Funds by the

District, unless required by law to be retained for a longer period, in which case the longer period shall apply.

10.3 Upon reasonable notice, the Grantee shall make all records and documents relating to the expenditure and application of the Funds available to the District Administrator for inspection, review, and audit.

10.4 Following an audit of the payment of the Funds, the Grantee shall repay to the District all amounts that the District determines were improperly paid to the Grantee, to the extent those payments are found by the District to have been caused by the negligent or intentional acts of the Grantee, its officers, officials, employees, agents, contractors, volunteers, or assigns.

11. Ownership and Maintenance. The Parties agree that the Grantee is solely responsible for the acquisition, design and construction of the Projects. This District shall not own the Projects, and shall have no obligation or responsibility for the acquisition, design, construction, operation, or maintenance of the Projects.

12. Hold Harmless and Indemnification.

12.1 To the maximum extent permitted by law, each Party shall defend, indemnify and hold harmless the other Party, and all of its officers, officials, employees, agents, contractors and volunteers, from any and all claims, injuries, damages, losses or suits, including attorney fees, arising out of or resulting from any negligent acts, errors, omissions of the indemnifying Party and its officers, officials, employees, agents, contractors and volunteers in performing obligations under this Agreement or in implementing the Projects. However, if any such injuries and damages to persons or property are caused by or result from the concurrent negligence of the District or its officers, officials, employees, agents, contractors and volunteers, and the Grantee or its officers, officials, employees, agents, contractors and volunteers, each Party's obligation hereunder applies only to the extent of the negligence of such Party or its officers, officials, employees, agents, contractors, or volunteers.

12.2 The foregoing indemnity is specifically and expressly intended to constitute a waiver of each Party's immunity under industrial insurance, Title 51 RCW, as respects the other Party only, and only to the extent necessary to provide the indemnified Party with a full and complete indemnity of claims made by the indemnitor's employees. This waiver has been mutually negotiated by the Parties.

13. Amendment. This Agreement may be modified by written instrument approved by the Grantee's governing body and the Board and signed by the authorized representatives of the Parties.

14. Waiver. No waiver by either Party of any term or condition of this Agreement shall be deemed or construed to be a waiver of any other term or condition, nor shall a waiver of any breach be deemed to constitute a waiver of any subsequent breach whether of the same or different provision of this Agreement. No waiver shall be effective unless made in writing.
15. No Third Party Rights. Nothing in this Agreement shall be construed to create any rights in or duties to any third party, nor any liability to or standard of care with reference to any third party.
16. Entirety. This Agreement is the complete expression of the terms hereto and any oral representations or understandings not incorporated are excluded. This Agreement merges and supersedes all prior negotiations, representations and agreements between the Parties relating to the Projects and constitutes the entire agreement between the Parties.
17. Counterparts. This Agreement may be signed in counterparts and, if so signed, shall be deemed one integrated document.
18. Governing Law; Venue. This Agreement shall be construed and interpreted in accordance with the laws of the State of Washington. In the event of a dispute, such dispute shall be litigated only in the Superior Court of Pierce County, Washington.
19. Severability. The invalidity or unenforceability of any provision in this Agreement shall not affect the validity or enforceability of any other provisions that can be given effect without the offending provision.
20. Administration. This Agreement will be jointly administered by the Grantee and the District. This Agreement does not create any separate legal or administrative entity. The District Administrator and the Public Works Director for Grantee, respectively, shall receive and give all notices, approvals, reports and documents under this Agreement.
21. Financing; Budget. This Agreement does not contemplate joint financing of the activities within its scope, nor does it contemplate a joint budget.
22. Property Acquisition and Disposition. This Agreement does not contemplate the joint acquisition of property by the parties. At termination, each party will remain the sole owner of its own property.
23. Recording. In accordance with RCW 38.34.040, this Agreement shall be filed with the Pierce County Auditor or listed on the web sites of the Parties prior to its effective date.

IN WITNESS WHEREOF, authorized representatives of the parties hereto have signed their names in the spaces below:

GRANTEE:  
CITY OF SUMNER

PIERCE COUNTY FLOOD CONTROL  
ZONE DISTRICT:

\_\_\_\_\_  
Name: \_\_\_\_\_  
Title: \_\_\_\_\_

\_\_\_\_\_  
Name: \_\_\_\_\_  
Title: \_\_\_\_\_

Date: \_\_\_\_\_

Date: \_\_\_\_\_

Attested to:

Attested to:

\_\_\_\_\_  
[name/title]

\_\_\_\_\_  
[name/title]

Date: \_\_\_\_\_

Date: \_\_\_\_\_

CITY OF SUMNER

\_\_\_\_\_  
City Administrator

Approved as to Form:

\_\_\_\_\_  
Attorney

## **Scope of Work for the City of Sumner's Four Projects Receiving FCZD Capital Improvement Plan Allocation.**

**Project ID Number:** SUM-1

**Project Name on the FCZD Submission:** Lower White River, RM 2.5-4.2 (24th Street)

**Project Name on the FZCD Approved Budget (Resolution 2025-5):** Lower White River, RM 2.5-4.2 (24th Street)

**Jurisdiction:** City of Sumner

**FCZD 2026 Allocation:** \$547,570 for Land Acquisition, \$5,000,000 for 2026 Construction.

**Budget:** The total project cost is \$52,681,585.19. Construction costs are estimated at \$16.2 million.

**Location:** The Left Bank of the White River between River Mile 2.5 and 4.2.

**Schedule:** The City of Sumner is expected to do construction between 2026 – 2028.

### **Total Project Description:**

This Lower White River project reduces flood risk in the Sumner Pacific Manufacturing Industrial Center while also restoring critical salmon habitat. The project will connect over 200 acres of floodplain to the river and add 2 miles of in-water habitat for salmon. Critical regional trail and utility infrastructure is also being relocated outside of the floodplain, including Power, Gas, Water, and Sewer. This funding request will help pay for earthwork, large wood installation, trail relocation, and PSE Power relocation.

### **Scope of Work for the FCZD Allocation:**

The FCZD allocation will be spent on earthwork (channel/floodplain grading, forested berm construction, and channel connections), large wood installation (approximately 130 structures total), trail relocation (approximately 2.5 miles), and PSE Power relocation (movement of transmission and distribution lines out of the floodplain).

Acquisition funds will be used to purchase land which is adjacent to in-river large wood structures, allowing for easier short term construction access versus a temporary bridge over the river. In addition, acquisition will allow land access for future maintenance to both existing flood infrastructure and new log structures.

### **Assumptions:**

- City of Sumner is responsible for all permitting and regulatory obligations for the project.
- City of Sumner will follow procurement requirements for public funding.
- Progress reports will be provided no less than quarterly.

### **Deliverables:**

- The reimbursement request will include documentation for the contractor's time, equipment, and materials.
- Quarterly Progress reports

Attachment A to FCZD Board of Supervisors Resolution No. 2026-4 Exhibit A

- Once the FCZD’s allocation has been expended, submit a final report that includes a written description of work completed with FCZD funds, photos, as-builts, and a final reimbursement request.
- 

**Project ID Number: SUM-2**

**Project Name on the FZCD Submission: Lower White River - Sumner Pointbar RM 3.9-4.5 RB**

**Project Name on the FZCD Approved Budget (Resolution 2025-5): Lower White River - Sumner Pointbar**

**Jurisdiction:** City of Sumner

**FCZD 2026 Allocation:** \$100,000 for Land Acquisition, \$242,450 for Planning/Design

**Budget:** The total project cost is \$44,730,216.50. Acquisition costs are estimated at \$18,481,850.00

**Location:** North of 16th St E in Sumner, on the right bank of the White River between RM 3.9 - 4.5.

**Schedule:** Acquisition in 2026.

**Total Project Description:** The project will reconnect 25 acres of floodplain to the White River, construct a floodwall along 16th Street, and create 1/4 mile of new in-water habitat. The floodplain is being lowered to reconnect and to increase floodplain capacity. The floodwall will block the flow path into the manufacturing industrial center, pushing more water into the downstream 24th street project. The new habitat will provide rearing for ESA-listed salmon. The property acquired for the project will relocate businesses/residents from the floodplain.

**Scope of Work for the FCZD Allocation:** FCZD funds will be spent to acquire one property, including paying for right-of-way agent negotiations, title reports, document preparation (Boundary Line Adjustments, etc.), and property clean-up post-acquisition.

**Assumptions:**

- City of Sumner is responsible for all permitting and regulatory obligations for the project.
- City of Sumner will follow procurement requirements for public funding.
- Progress reports will be provided no less than quarterly.

**Deliverables:**

- The reimbursement request will include documentation for the contractor’s time, equipment, and materials.
- Quarterly Progress reports
- Once the FCZD’s allocation has been expended, submit a final report that includes a written description of work completed with FCZD funds, photos, as-builts, and a final reimbursement request.

**Project ID Number: SUM-3**

**Project Name on the FZCD Submission: Lower White River - Stewart Setback RM 4.4-4.9**

**Project Name on the FZCD Approved Budget (Resolution 2025-5): Lower White River - Stewart Setback**

**Jurisdiction:** City of Sumner

**FCZD 2026 Allocation:** \$3,000,000 for 2026 for Land Acquisition, \$270,000 for Planning/Design

**Budget:** The total project cost is \$14,770,000. Acquisition costs are estimated at \$2,900,000.

**Location:** Left bank of the White River, south of the Stewart Road Bridge from RM 4.9-4.4.

**Schedule:** Acquisition in 2026.

**Total Project Description:** The portions of property within the shoreline buffer will be acquired along the left bank of the White River. Once acquired, the existing levee and revetment will be removed, and a floodwall will be installed back ~200 feet. The floodplain will be lowered and reconnected, increasing channel storage and connecting the floodplain underneath the Stewart Road Bridge to the Countyline setback. This project will increase channel capacity and take pressure off the opposing bank, which has experienced erosion. The immediate grant request will help to acquire the property and complete the design.

**Scope of Work for the FCZD Allocation:** FCZD funds will be spent to acquire three properties, including paying for right-of-way agent negotiations, title reports, document preparation (Boundary Line Adjustments, etc.), and property clean-up post-acquisition.

**Assumptions:**

- City of Sumner is responsible for all permitting and regulatory obligations for the project.
- City of Sumner will follow procurement requirements for public funding.
- Progress reports will be provided no less than quarterly.

**Deliverables:**

- The reimbursement request will include documentation for the contractor's time, equipment, and materials.
  - Quarterly Progress reports
  - Once the FCZD's allocation has been expended, submit a final report that includes a written description of work completed with FCZD funds, photos, as-builts, and a final reimbursement request.
-

**Project ID Number: SUM-4**

**Project Name on the FZCD Submission: Lower White River - Stewart Road Bridge RM 5.0**

**Project Name on the FZCD Approved Budget (Resolution 2025-5): Lower White River - Stewart Road Bridge**

**Jurisdiction:** City of Sumner

**FCZD 2026 Allocation:** \$2,500,000 for 2026 for Construction.

**Budget:** The total project cost is \$41,445,027. Construction costs are estimated at \$37,319,576.

**Location:** Stewart Road between Butte Avenue and 140th Ave Ct E.

**Schedule:** The City of Sumner is expected to do construction between 2026 – 2028.

**Total Project Description:** The project removes the existing 2-lane “bottleneck” bridge and replaces it with a new 4-lane bridge with a shared-use path over the White River that is compatible with the roadway sections on either side of the river. The new structure and associated utilities will be up to 16 feet higher than the existing bridge to account for the 100-year flooding event with expected future sediment aggradation. The new structure is significantly longer to reduce the existing river channel constriction, allowing the river more channel area to meander more naturally and eliminating the “chokepoint” created by the existing structure. The design also incorporates flexibility for future floodplain expansion and channel migration by constructing abutments that allow for conversion to piers, and adding bridge spans to further lengthen the bridge if future projects further expand the floodplain.

Both the lengthening and raising of the structure will increase channel capacity and reduce flood risk to the City and upriver communities while increasing floodplain connectivity between the Countyline Setback and future Butte Pit projects immediately upstream and the downstream Lower White River Flood Protection projects.

While the project has already received significant grant funding, none of the received grants have been specific to the project's habitat and floodplain benefits.

**Scope of Work for the FCZD Allocation:** The FCZD allocation will be spent on the construction of the new bridge structure, roadway, and water/sewer utilities to bring them above the 100-year flood elevation. The funding will also support construction management costs.

**Assumptions:**

- City of Sumner is responsible for all permitting and regulatory obligations for the project.
- City of Sumner will follow procurement requirements for public funding.
- Progress reports will be provided no less than quarterly.

**Deliverables:**

- The reimbursement request will include documentation for the contractor’s time, equipment, and materials.

Attachment A to FCZD Board of Supervisors Resolution No. 2026-4 Exhibit A

- Quarterly Progress reports
- Once the FCZD's allocation has been expended, submit a final report that includes a written description of work completed with FCZD funds, photos, as-builts, and a final reimbursement request.

---

**SUBJECT:** Resolution No. 1750 - Stormwater Capacity Grant Acceptance

**CATEGORY:** Consent

---

**BUDGET IMPACT:**

Expenditure Required: None

Within Budget Allocation: N/A

---

**ATTACHMENTS:**

1. Resolution No. 1750 - Stormwater Capacity Grant Acceptance

**STAFF CONTACT:** Robert Wright, Assistant Engineering Manager

---

**SUMMARY BACKGROUND:**

The City's municipal stormwater permit requires various actions ranging from reviewing development, educating the public on stormwater impacts, preventing spills and more from reaching the river, etc. In order to help create capacity for this type of work, the Department of Ecology awards "Stormwater Capacity Grants" to municipalities every 2 years. These grants are non-competitive and can be used for any eligible permit expense. In the past, the City has used this grant to help fund staff time, purchase spill response materials, wrap our street sweeper and garbage truck with stormwater educational messaging, and more. The grant was awarded in the amount of \$120,000 and any expenses between July 1, 2025, through March 1, 2027, are eligible for reimbursement.

---

**COUNCIL COMMITTEE/STUDY SESSION:** Public Works Committee

**MEETING/STUDY SESSION DATE:** 4/21/2026

**COMMITTEE RECOMMENDATION:** Do Pass

**STAFF RECOMMENDATIONS/MOTION:**

A motion to adopt Resolution No. 1750 - Accepting of \$120,000 in grant funds from the Department of Ecology for use in the implementation of the City's Municipal Stormwater Permit, and authorizing the Mayor to execute any and all documents necessary to accept the funds, substantially in a form as approved by the City Attorney.

**RESOLUTION NO. 1750  
CITY OF SUMNER, WASHINGTON**

**A RESOLUTION OF THE CITY OF SUMNER, WASHINGTON, ACCEPTING GRANT FROM THE WASHINGTON STATE DEPARTMENT OF ECOLOGY**

**WHEREAS**, the city is required to implement certain actions under our municipal stormwater permit; and

**WHEREAS**, to help accomplish and fund these actions the Department of Ecology provides non-competitive grants referred to as Stormwater Capacity Grants; and

**WHEREAS**, the City of Sumner has received one of these grants in the amount of \$120,000; and

**WHEREAS**, City Council acceptance of the grant and authorization for the Mayor to execute a grant agreement is required by law; and

**WHEREAS**, it is in the City's interests to accept the grant funds and enter into any necessary grant agreements regarding the same.

**NOW, THEREFORE, BE IT RESOLVED BY THE CITY COUNCIL OF THE CITY OF SUMNER, WASHINGTON:**

**Section 1.** That the City Council of the City of Sumner, Washington, does hereby accept the Stormwater Capacity grant and authorizes the Mayor to execute any necessary funding agreements, and any and all documents necessary to carry out and effectuate the grant acceptance.

**Section 2. Corrections by City Clerk or Code Reviser.** Upon approval of the city attorney, the city clerk and the code reviser are authorized to make necessary corrections to this resolution, including but not limited to the correction of clerical errors; or references to other local, state, or federal laws, codes, rules, or regulations.

**Section 3.** The Mayor is hereby authorized to implement such administrative procedures as may be necessary to carry out the directions of this legislation

**Section 4. Effective Date.** This resolution shall take effect and be in full force immediately upon passage by the City Council.

**ADOPTED AND APPROVED** this \_\_\_\_\_.

\_\_\_\_\_  
Mayor Carla S. Bowman

**ATTEST:**

**APPROVED AS TO FORM:**

\_\_\_\_\_  
Michelle Converse, CMC, City Clerk

\_\_\_\_\_  
City Attorney Andrea Marquez



## Agreement No. WQSWCAP-2527-Sumner-00183

### WATER QUALITY STORMWATER CAPACITY AGREEMENT

#### BETWEEN

THE STATE OF WASHINGTON DEPARTMENT OF ECOLOGY

#### AND

CITY OF SUMNER

This is a binding Agreement entered into by and between the state of Washington, Department of Ecology, hereinafter referred to as “ECOLOGY,” and City of Sumner, hereinafter referred to as the “RECIPIENT,” to carry out with the provided funds activities described herein.

---

### GENERAL INFORMATION

Project Title:	2025-2027 Biennial Stormwater Capacity Grant
Total Cost:	\$120,000.00
Total Eligible Cost:	\$120,000.00
Ecology Share:	\$120,000.00
Recipient Share:	\$0.00
The Effective Date of this Agreement is:	07/01/2025
The Expiration Date of this Agreement is no later than:	03/31/2027
Project Type:	Capacity Grant

#### Project Short Description:

This project will assist Phase I and II Permittees in implementation or management of municipal stormwater programs.

#### Project Long Description:

N/A

#### Overall Goal:

This project will improve water quality in the State of Washington by reducing stormwater pollutants discharged to state water bodies.

Agreement No: WQSWCAP-2527-Sumner-00183  
 Project Title: 2025-2027 Biennial Stormwater Capacity Grant  
 Recipient Name: City of Sumner

**RECIPIENT INFORMATION**

Organization Name: City of Sumner

Federal Tax ID: 91-6001282  
 UEI Number: Q3ZKNC1EXZC9

Mailing Address: 1104 Maple St  
 Sumner, WA 98390

Physical Address: 1104 Maple St  
 Sumner, Washington 98390

Organization Email: kassandr@sumnerwa.gov

**Contacts**

<p><b>Project Manager</b></p>	<p>Robert Wright                  Local Source Control Specialist</p> <p>1104 Maple St Suite 260                  Sumner, Washington 98390                  Email: robertw@sumnerwa.gov                  Phone: (253) 299-5708</p>
<p><b>Billing Contact</b></p>	<p>Dori Franich                  Financial Services Manager</p> <p>1104 Maple Street                  Sumner, Washington 98390                  Email: dorif@sumnerwa.gov                  Phone: (253) 299-5545</p>
<p><b>Authorized Signatory</b></p>	<p>Kassandra Raymond                  Chief Financial Officer</p> <p>1104 Maple Street                  Sumner, Washington 98390                  Email: kassandr@sumnerwa.gov                  Phone: (253) 299-5541</p>

Agreement No: WQSWCAP-2527-Summer-00183  
Project Title: 2025-2027 Biennial Stormwater Capacity Grant  
Recipient Name: City of Sumner

**ECOLOGY INFORMATION**

Mailing Address: Department of Ecology  
Water Quality  
PO BOX 47600  
Olympia, WA 98504-7600

Physical Address: Water Quality  
300 Desmond Drive SE  
Lacey, WA 98503

**Contacts**

<b>Project Manager</b>	<p>Kyle Graunke</p> <p>PO Box 47600 Olympia, Washington 98504-7600 Email: kygr461@ecy.wa.gov Phone: (360) 628-3890</p>
<b>Financial Manager</b>	<p>Kyle Graunke</p> <p>PO Box 47600 Olympia, Washington 98504-7600 Email: kygr461@ecy.wa.gov Phone: (360) 628-3890</p>

**AUTHORIZING SIGNATURES**

RECIPIENT agrees to furnish the necessary personnel, equipment, materials, services, and otherwise do all things necessary for or incidental to the performance of work as set forth in this Agreement.

RECIPIENT acknowledges that they had the opportunity to review the entire Agreement, including all the terms and conditions of this Agreement, Scope of Work, attachments, and incorporated or referenced documents, as well as all applicable laws, statutes, rules, regulations, and guidelines mentioned in this Agreement. Furthermore, the RECIPIENT has read, understood, and accepts all requirements contained within this Agreement.

This Agreement contains the entire understanding between the parties, and there are no other understandings or representations other than as set forth, or incorporated by reference, herein.

No subsequent modifications or amendments to this agreement will be of any force or effect unless in writing, signed by authorized representatives of the RECIPIENT and ECOLOGY and made a part of this agreement. ECOLOGY and RECIPIENT may change their respective staff contacts without the concurrence of either party.

This Agreement shall be subject to the written approval of Ecology’s authorized representative and shall not be binding until so approved.

The signatories to this Agreement represent that they have the authority to execute this Agreement and bind their respective organizations to this Agreement.

IN WITNESS WHEREOF: the parties hereto, having read this Agreement in its entirety, including all attachments, do agree in each and every particular and have thus set their hands hereunto.

Washington State  
Department of Ecology

City of Sumner

By: \_\_\_\_\_

By: \_\_\_\_\_

Jon Kenning, PhD  
Water Quality  
Program Manager  
Date

Kassandra Raymond  
Chief Financial Officer  
Date

Template Approved to Form by  
Attorney General's Office

Agreement No: WQSWCAP-2527-Sumner-00183  
Project Title: 2025-2027 Biennial Stormwater Capacity Grant  
Recipient Name: City of Sumner

Carla S. Bowman

---

Mayor

Date

**SCOPE OF WORK**

Task Number: 1 **Task Cost:** \$0.00

Task Title: Project Administration/Management

Task Description:

A. The RECIPIENT shall carry out all work necessary to meet ECOLOGY grant or loan administration requirements. Responsibilities include, but are not limited to: Maintenance of project records; submittal of requests for reimbursement and corresponding backup documentation; progress reports; and the EAGL (Ecology Administration of Grants and Loans) recipient closeout report (including photos, if applicable). In the event that the RECIPIENT elects to use a contractor to complete project elements, the RECIPIENT shall retain responsibility for the oversight and management of this funding agreement.

B. The RECIPIENT shall keep documentation that demonstrates the project is in compliance with applicable procurement, contracting, and interlocal agreement requirements; permitting requirements, including application for, receipt of, and compliance with all required permits, licenses, easements, or property rights necessary for the project; and submittal of required performance items. This documentation shall be available upon request.

C. The RECIPIENT shall maintain effective communication with ECOLOGY and maintain up-to-date staff contact information in the EAGL system. The RECIPIENT shall carry out this project in accordance with any completion dates outlined in this agreement.

Task Goal Statement:

Properly managed and fully documented project that meets ECOLOGY’s grant and loan administrative requirements.

Task Expected Outcome:

- \* Timely and complete submittal of requests for reimbursement, quarterly progress reports, and Recipient Closeout Report.
- \* Properly maintained project documentation.

**Project Administration/Management**

**Deliverables**

Number	Description	Due Date
1.1	Progress Reports that include descriptions of work accomplished, project challenges or changes in the project schedule. Submitted at least quarterly.	
1.2	Recipient Closeout Report (EAGL Form).	

## SCOPE OF WORK

Task Number: 2 **Task Cost:** \$120,000.00

Task Title: Permit Implementation

### Task Description:

Conduct work related to implementation of municipal stormwater National Pollutant Discharge Elimination System (NPDES) permit requirements. If the RECIPIENT is out of compliance with the Municipal Stormwater National Pollutant Discharge Elimination System (NPDES) permit, the RECIPIENT will use funds to attain compliance where applicable. The following is a list of elements projects may include:

- 1) Public education and outreach activities, including stewardship activities.
- 2) Public involvement and participation activities.
- 3) Illicit discharge detection and elimination (IDDE) program activities, including:
  - a) Mapping of municipal separate storm sewer systems (MS4s).
  - b) Staff training.
  - c) Activities to identify and remove illicit stormwater discharges.
  - d) Field screening procedures.
  - e) Complaint hotline database or tracking system improvements.
- 4) Activities to support programs to control runoff from new development, redevelopment, and construction sites, including:
  - a) Development of an ordinance and associated technical manual or update of applicable codes.
  - b) Inspections before, during, and upon completion of construction, or for post-construction long-term maintenance.
  - c) Training for plan review or inspection staff.
  - d) Participation in applicable watershed planning effort.
- 5) Pollution prevention, good housekeeping, and operation and maintenance program activities, such as:
  - a) Inspecting and/or maintaining the MS4 infrastructure.
  - b) Developing and/or implementing policies, procedures, or stormwater pollution prevention plans at municipal properties or facilities.
- 6) Annual reporting activities.
- 7) Establishing and refining stormwater utilities, including stable rate structures.
- 8) Water quality monitoring to implement permit requirements for a Water Cleanup Plan (Total Maximum Daily Load (TMDL)). Note that any monitoring funded by this program requires submittal of a Quality Assurance Project Plan (QAPP) that ECOLOGY approves prior to awarding funding for monitoring. Monitoring must directly meet a Phase I or II permit requirement.
- 9) Structural stormwater controls program activities (Phase I permit requirement).
- 10) Source control for existing development (Phase I permit requirement), including:
  - a) Inventory and inspection program.
  - b) Technical assistance and enforcement.
  - c) Staff training.
- 11) Equipment purchases that result directly in improved permit compliance. Equipment purchases must be specific to implementing a permit requirement (such as a vactor truck) rather than general use (such as a pick-up truck). Equipment purchases over \$5,000.00 must be pre-approved by ECOLOGY.

Documentation of all tasks completed is required. Documentation may include field reports, dates and number of inspections conducted, dates of trainings held and participant lists, number of illicit discharges investigated and removed, summaries of planning, stormwater utility or procedural updates, annual reports, copies of approved QAPPs, summaries of structural or source control activities, summaries of how equipment purchases have increased or

Agreement No: WQSWCAP-2527-Sumner-00183  
 Project Title: 2025-2027 Biennial Stormwater Capacity Grant  
 Recipient Name: City of Sumner

improved permit compliance.

Ineligible expenses include capital construction projects, incentives or give-a-ways, grant application preparation, Technology Assessment Protocol - Ecology (TAPE) review for proprietary treatment systems, or tasks that do not support Municipal Stormwater Permit implementation.

Task Goal Statement:

This task will improve water quality in the State of Washington by reducing the pollutants delivered by stormwater to lakes, streams, and the Puget Sound by implementing measures required by Phase I and II NPDES permits.

Task Expected Outcome:

RECIPIENTs will implement measures required by Phase I and II NPDES permits.

**Permit Implementation**

**Deliverables**

Number	Description	Due Date
2.1	Documentation of tasks completed	

**BUDGET**

**Funding Distribution EG260241**

**NOTE:** *The above funding distribution number is used to identify this specific agreement and budget on payment remittances and may be referenced on other communications from ECOLOGY. Your agreement may have multiple funding distribution numbers to identify each budget.*

Funding Title: 2025-2027 Stormwater Capacity Grant  
 Funding Type: Grant  
 Funding Effective Date: 07/01/2025 Funding Expiration Date: 03/31/2027  
 Funding Source:

Title: Model Toxics Control Stormwater Account (MTCSA)  
 Fund: FD  
 Type: State  
 Funding Source %: 100%  
 Description: MTCSA

Approved Indirect Costs Rate: Approved State Indirect Rate: 30%  
 Recipient Match %: 0%  
 InKind Interlocal Allowed: No  
 InKind Other Allowed: No  
 Is this Funding Distribution used to match a federal grant? No

2025-2027 Stormwater Capacity Grant	Task Total
Permit Implementation	\$ 120,000.00

**Total: \$ 120,000.00**

**Funding Distribution Summary**

**Recipient / Ecology Share**

<b>Funding Distribution Name</b>	<b>Recipient Match %</b>	<b>Recipient Share</b>	<b>Ecology Share</b>	<b>Total</b>
2025-2027 Stormwater Capacity Grant	0.00 %	\$ 0.00	\$ 120,000.00	\$ 120,000.00
<b>Total</b>		<b>\$ 0.00</b>	<b>\$ 120,000.00</b>	<b>\$ 120,000.00</b>

**AGREEMENT SPECIFIC TERMS AND CONDITIONS**

N/A

**SPECIAL TERMS AND CONDITIONS**

**GENERAL FEDERAL CONDITIONS**

**If a portion or all of the funds for this agreement are provided through federal funding sources or this agreement is used to match a federal grant award, the following terms and conditions apply to you.**

**A. CERTIFICATION REGARDING SUSPENSION, DEBARMENT, INELIGIBILITY OR VOLUNTARY**

**EXCLUSION:**

1. The RECIPIENT/CONTRACTOR, by signing this agreement, certifies that it is not suspended, debarred, proposed for debarment, declared ineligible or otherwise excluded from contracting with the federal government, or from receiving contracts paid for with federal funds. If the RECIPIENT/CONTRACTOR is unable to certify to the statements contained in the certification, they must provide an explanation as to why they cannot.
2. The RECIPIENT/CONTRACTOR shall provide immediate written notice to ECOLOGY if at any time the RECIPIENT/CONTRACTOR learns that its certification was erroneous when submitted or had become erroneous by reason of changed circumstances.
3. The terms covered transaction, debarred, suspended, ineligible, lower tier covered transaction, participant, person, primary covered transaction, principal, proposal, and voluntarily excluded, as used in this clause, have the meaning set out in the Definitions and Coverage sections of rules implementing Executive Order 12549. You may contact ECOLOGY for assistance in obtaining a copy of those regulations.
4. The RECIPIENT/CONTRACTOR agrees it shall not knowingly enter into any lower tier covered transaction with a person who is proposed for debarment under the applicable Code of Federal Regulations, debarred, suspended, declared ineligible, or voluntarily excluded from participation in this covered transaction.
5. The RECIPIENT/CONTRACTOR further agrees by signing this agreement, that it will include this clause titled

Agreement No: WQSWCAP-2527-Summer-00183  
 Project Title: 2025-2027 Biennial Stormwater Capacity Grant  
 Recipient Name: City of Sumner

“CERTIFICATION REGARDING SUSPENSION, DEBARMENT, INELIGIBILITY OR VOLUNTARY EXCLUSION” without modification in all lower tier covered transactions and in all solicitations for lower tier covered transactions.

6. Pursuant to 2CFR180.330, the RECIPIENT/CONTRACTOR is responsible for ensuring that any lower tier covered transaction complies with certification of suspension and debarment requirements.
7. RECIPIENT/CONTRACTOR acknowledges that failing to disclose the information required in the Code of Federal Regulations may result in the delay or negation of this funding agreement, or pursuance of legal remedies, including suspension and debarment.
8. RECIPIENT/CONTRACTOR agrees to keep proof in its agreement file, that it, and all lower tier recipients or contractors, are not suspended or debarred, and will make this proof available to ECOLOGY before requests for reimbursements will be approved for payment. RECIPIENT/CONTRACTOR must run a search in <http://www.sam.gov> and print a copy of completed searches to document proof of compliance.

#### B. FEDERAL FUNDING ACCOUNTABILITY AND TRANSPARENCY ACT (FFATA) REPORTING REQUIREMENTS:

CONTRACTOR/RECIPIENT must complete the FFATA Data Collection Form (ECY 070-395) and return it with the signed agreement to ECOLOGY.

Any CONTRACTOR/RECIPIENT that meets each of the criteria below must report compensation for its five top executives using the FFATA Data Collection Form.

- Receives more than \$30,000 in federal funds under this award.
- Receives more than 80 percent of its annual gross revenues from federal funds.
- Receives more than \$25,000,000 in annual federal funds.

Ecology will not pay any invoices until it has received a completed and signed FFATA Data Collection Form. Ecology is required to report the FFATA information for federally funded agreements, including the required Unique Entity Identifier in [www.sam.gov](http://www.sam.gov) <http://www.sam.gov> within 30 days of agreement signature. The FFATA information will be available to the public at [www.usaspending.gov](http://www.usaspending.gov) <http://www.usaspending.gov>.

For more details on FFATA requirements, see [www.fsrc.gov](http://www.fsrc.gov) <http://www.fsrc.gov>.

#### C. FEDERAL FUNDING PROHIBITION ON CERTAIN TELECOMMUNICATIONS OR VIDEO SURVEILLANCE SERVICES OR EQUIPMENT:

As required by 2 CFR 200.216, federal grant or loan recipients and subrecipients are prohibited from obligating or expending loan or grant funds to:

1. Procure or obtain;
2. Extend or renew a contract to procure or obtain; or
3. Enter into a contract (or extend or renew a contract) to procure or obtain equipment, services, or systems that use covered telecommunications equipment, video surveillance services or services as a substantial or essential component of any system, or as critical technology as part of any system. As described in [Public Law 115-232](https://www.govinfo.gov/content/pkg/PLAW-115publ232/pdf/PLAW-115publ232.pdf) <https://www.govinfo.gov/content/pkg/PLAW-115publ232/pdf/PLAW-115publ232.pdf>, section 889, covered telecommunications equipment is telecommunications equipment produced by Huawei Technologies Company or ZTE Corporation (or any subsidiary or affiliate of such entities).

Agreement No: WQSWCAP-2527-Sumner-00183  
Project Title: 2025-2027 Biennial Stormwater Capacity Grant  
Recipient Name: City of Sumner

Recipients, subrecipients, and borrowers also may not use federal funds to purchase certain prohibited equipment, systems, or services, including equipment, systems, or services produced or provided by entities identified in section 889, are recorded in the [System for Award Management \(SAM\) <https://sam.gov/SAM/>](https://sam.gov/SAM/) exclusion list.

## GENERAL TERMS AND CONDITIONS

### Pertaining to Grant and Loan Agreements With the state of Washington, Department of Ecology

#### GENERAL TERMS AND CONDITIONS

For DEPARTMENT OF ECOLOGY GRANTS and LOANS

07/01/2023 Version

#### 1. ADMINISTRATIVE REQUIREMENTS

- a) RECIPIENT shall follow the "Administrative Requirements for Recipients of Ecology Grants and Loans – EAGL Edition." (<https://fortress.wa.gov/ecy/publications/SummaryPages/2301002.html>)
- b) RECIPIENT shall complete all activities funded by this Agreement and be fully responsible for the proper management of all funds and resources made available under this Agreement.
- c) RECIPIENT agrees to take complete responsibility for all actions taken under this Agreement, including ensuring all subgrantees and contractors comply with the terms and conditions of this Agreement. ECOLOGY reserves the right to request proof of compliance by subgrantees and contractors.
- d) RECIPIENT's activities under this Agreement shall be subject to the review and approval by ECOLOGY for the extent and character of all work and services.

#### 2. AMENDMENTS AND MODIFICATIONS

This Agreement may be altered, amended, or waived only by a written amendment executed by both parties. No subsequent modification(s) or amendment(s) of this Agreement will be of any force or effect unless in writing and signed by authorized representatives of both parties. ECOLOGY and the RECIPIENT may change their respective staff contacts and administrative information without the concurrence of either party.

#### 3. ACCESSIBILITY REQUIREMENTS FOR COVERED TECHNOLOGY

The RECIPIENT must comply with the Washington State Office of the Chief Information Officer, OCIO Policy no. 188, Accessibility (<https://ocio.wa.gov/policy/accessibility>) as it relates to "covered technology." This requirement applies to all products supplied under the Agreement, providing equal access to information technology by individuals with disabilities, including and not limited to web sites/pages, web-based applications, software systems, video and audio content, and electronic documents intended for publishing on Ecology's public web site.

#### 4. ARCHAEOLOGICAL AND CULTURAL RESOURCES

RECIPIENT shall take all reasonable action to avoid, minimize, or mitigate adverse effects to archaeological and historic archaeological sites, historic buildings/structures, traditional cultural places, sacred sites, or other cultural resources, hereby referred to as Cultural Resources.

The RECIPIENT must agree to hold harmless ECOLOGY in relation to any claim related to Cultural Resources discovered, disturbed, or damaged due to the RECIPIENT's project funded under this Agreement.

RECIPIENT shall:

- a) Contact the ECOLOGY Program issuing the grant or loan to discuss any Cultural Resources requirements for their project:
  - Cultural Resource Consultation and Review should be initiated early in the project planning process and must be completed prior to expenditure of Agreement funds as required by applicable State and Federal requirements.
  - \* For state funded construction, demolition, or land acquisitions, comply with Governor Executive Order 21-02, Archaeological and Cultural Resources.
  - For projects with any federal involvement, comply with the National Historic Preservation Act of 1966 (Section 106).

Agreement No: WQSWCAP-2527-Summer-00183  
 Project Title: 2025-2027 Biennial Stormwater Capacity Grant  
 Recipient Name: City of Sumner

b) If required by the ECOLOGY Program, submit an Inadvertent Discovery Plan (IDP) to ECOLOGY prior to implementing any project that involves field activities. ECOLOGY will provide the IDP form.

RECIPIENT shall:

- Keep the IDP at the project site.
  - Make the IDP readily available to anyone working at the project site.
  - Discuss the IDP with staff, volunteers, and contractors working at the project site.
  - Implement the IDP when Cultural Resources or human remains are found at the project site.
- c) If any Cultural Resources are found while conducting work under this Agreement, follow the protocol outlined in the project IDP.
- Immediately stop work and notify the ECOLOGY Program, who will notify the Department of Archaeology and Historic Preservation at (360) 586-3065, any affected Tribe, and the local government.
- d) If any human remains are found while conducting work under this Agreement, follow the protocol outlined in the project IDP.
- Immediately stop work and notify the local Law Enforcement Agency or Medical Examiner/Coroner's Office, the Department of Archaeology and Historic Preservation at (360) 790-1633, and then the ECOLOGY Program.
- e) Comply with RCW 27.53, RCW 27.44, and RCW 68.50.645, and all other applicable local, state, and federal laws protecting Cultural Resources and human remains.

#### 5. ASSIGNMENT

No right or claim of the RECIPIENT arising under this Agreement shall be transferred or assigned by the RECIPIENT.

#### 6. COMMUNICATION

RECIPIENT shall make every effort to maintain effective communications with the RECIPIENT's designees, ECOLOGY, all affected local, state, or federal jurisdictions, and any interested individuals or groups.

#### 7. COMPENSATION

- a) Any work performed prior to effective date of this Agreement will be at the sole expense and risk of the RECIPIENT. ECOLOGY must sign the Agreement before any payment requests can be submitted.
- b) Payments will be made on a reimbursable basis for approved and completed work as specified in this Agreement.
- c) RECIPIENT is responsible to determine if costs are eligible. Any questions regarding eligibility should be clarified with ECOLOGY prior to incurring costs. Costs that are conditionally eligible require approval by ECOLOGY prior to expenditure.
- d) RECIPIENT shall not invoice more than once per month unless agreed on by ECOLOGY.
- e) ECOLOGY will not process payment requests without the proper reimbursement forms, Progress Report and supporting documentation. ECOLOGY will provide instructions for submitting payment requests.
- f) ECOLOGY will pay the RECIPIENT thirty (30) days after receipt of a properly completed request for payment.
- g) RECIPIENT will receive payment through Washington State's Office of Financial Management's Statewide Payee Desk. To receive payment you must register as a statewide vendor by submitting a statewide vendor registration form and an IRS W-9 form at website, <https://ofm.wa.gov/it-systems/statewide-vendorpayee-services>. If you have questions about the vendor registration process, you can contact Statewide Payee Help Desk at (360) 407-8180 or email [PayeeRegistration@ofm.wa.gov](mailto:PayeeRegistration@ofm.wa.gov).
- h) ECOLOGY may, at its sole discretion, withhold payments claimed by the RECIPIENT if the RECIPIENT fails to satisfactorily comply with any term or condition of this Agreement.
- i) Monies withheld by ECOLOGY may be paid to the RECIPIENT when the work described herein, or a portion thereof, has been completed if, at ECOLOGY's sole discretion, such payment is reasonable and approved according to this Agreement, as appropriate, or upon completion of an audit as specified herein.

Agreement No: WQSWCAP-2527-Summer-00183  
 Project Title: 2025-2027 Biennial Stormwater Capacity Grant  
 Recipient Name: City of Sumner

j) RECIPIENT must submit within thirty (30) days after the expiration date of this Agreement, all financial, performance, and other reports required by this Agreement. Failure to comply may result in delayed reimbursement.

#### 8. COMPLIANCE WITH ALL LAWS

RECIPIENT agrees to comply fully with all applicable federal, state and local laws, orders, regulations, and permits related to this Agreement, including but not limited to:

- a) RECIPIENT agrees to comply with all applicable laws, regulations, and policies of the United States and the State of Washington which affect wages and job safety.
- b) RECIPIENT agrees to be bound by all applicable federal and state laws, regulations, and policies against discrimination.
- c) RECIPIENT certifies full compliance with all applicable state industrial insurance requirements.
- d) RECIPIENT agrees to secure and provide assurance to ECOLOGY that all the necessary approvals and permits required by authorities having jurisdiction over the project are obtained. RECIPIENT must include time in their project timeline for the permit and approval processes.

ECOLOGY shall have the right to immediately terminate for cause this Agreement as provided herein if the RECIPIENT fails to comply with above requirements.

If any provision of this Agreement violates any statute or rule of law of the state of Washington, it is considered modified to conform to that statute or rule of law.

#### 9. CONFLICT OF INTEREST

RECIPIENT and ECOLOGY agree that any officer, member, agent, or employee, who exercises any function or responsibility in the review, approval, or carrying out of this Agreement, shall not have any personal or financial interest, direct or indirect, nor affect the interest of any corporation, partnership, or association in which he/she is a part, in this Agreement or the proceeds thereof.

#### 10. CONTRACTING FOR GOODS AND SERVICES

RECIPIENT may contract to buy goods or services related to its performance under this Agreement. RECIPIENT shall award all contracts for construction, purchase of goods, equipment, services, and professional architectural and engineering services through a competitive process, if required by State law. RECIPIENT is required to follow procurement procedures that ensure legal, fair, and open competition.

RECIPIENT must have a standard procurement process or follow current state procurement procedures. RECIPIENT may be required to provide written certification that they have followed their standard procurement procedures and applicable state law in awarding contracts under this Agreement.

ECOLOGY reserves the right to inspect and request copies of all procurement documentation, and review procurement practices related to this Agreement. Any costs incurred as a result of procurement practices not in compliance with state procurement law or the RECIPIENT's normal procedures may be disallowed at ECOLOGY's sole discretion.

#### 11. DISPUTES

When there is a dispute with regard to the extent and character of the work, or any other matter related to this Agreement the determination of ECOLOGY will govern, although the RECIPIENT shall have the right to appeal decisions as provided for below:

- a) RECIPIENT notifies the funding program of an appeal request.
- b) Appeal request must be in writing and state the disputed issue(s).
- c) RECIPIENT has the opportunity to be heard and offer evidence in support of its appeal.
- d) ECOLOGY reviews the RECIPIENT's appeal.
- e) ECOLOGY sends a written answer within ten (10) business days, unless more time is needed, after concluding the

review.

The decision of ECOLOGY from an appeal will be final and conclusive, unless within thirty (30) days from the date of such decision, the RECIPIENT furnishes to the Director of ECOLOGY a written appeal. The decision of the Director or duly authorized representative will be final and conclusive.

The parties agree that this dispute process will precede any action in a judicial or quasi-judicial tribunal.

Appeals of the Director's decision will be brought in the Superior Court of Thurston County. Review of the Director's decision will not be taken to Environmental and Land Use Hearings Office.

Pending final decision of a dispute, the RECIPIENT agrees to proceed diligently with the performance of this Agreement and in accordance with the decision rendered.

Nothing in this Agreement will be construed to limit the parties' choice of another mutually acceptable method, in addition to the dispute resolution procedure outlined above.

## 12. ENVIRONMENTAL DATA STANDARDS

a) RECIPIENT shall prepare a Quality Assurance Project Plan (QAPP) for a project that collects or uses environmental measurement data. RECIPIENTS unsure about whether a QAPP is required for their project shall contact the ECOLOGY Program issuing the grant or loan. If a QAPP is required, the RECIPIENT shall:

- Use ECOLOGY's QAPP Template/Checklist provided by the ECOLOGY, unless ECOLOGY Quality Assurance (QA) officer or the Program QA coordinator instructs otherwise.
- Follow ECOLOGY's Guidelines for Preparing Quality Assurance Project Plans for Environmental Studies, July 2004 (Ecology Publication No. 04-03-030).
- Submit the QAPP to ECOLOGY for review and approval before the start of the work.

b) RECIPIENT shall submit environmental data that was collected on a project to ECOLOGY using the Environmental Information Management system (EIM), unless the ECOLOGY Program instructs otherwise. The RECIPIENT must confirm with ECOLOGY that complete and correct data was successfully loaded into EIM, find instructions at: <http://www.ecy.wa.gov/eim>.

c) RECIPIENT shall follow ECOLOGY's data standards when Geographic Information System (GIS) data is collected and processed. Guidelines for Creating and Accessing GIS Data are available at: <https://ecology.wa.gov/Research-Data/Data-resources/Geographic-Information-Systems-GIS/Standards>. RECIPIENT, when requested by ECOLOGY, shall provide copies to ECOLOGY of all final GIS data layers, imagery, related tables, raw data collection files, map products, and all metadata and project documentation.

## 13. GOVERNING LAW

This Agreement will be governed by the laws of the State of Washington, and the venue of any action brought hereunder will be in the Superior Court of Thurston County.

## 14. INDEMNIFICATION

ECOLOGY will in no way be held responsible for payment of salaries, consultant's fees, and other costs related to the project described herein, except as provided in the Scope of Work.

To the extent that the Constitution and laws of the State of Washington permit, each party will indemnify and hold the other harmless from and against any liability for any or all injuries to persons or property arising from the negligent act or omission of that party or that party's agents or employees arising out of this Agreement.

## 15. INDEPENDENT STATUS

The employees, volunteers, or agents of each party who are engaged in the performance of this Agreement will continue to be employees, volunteers, or agents of that party and will not for any purpose be employees, volunteers, or agents of the other party.

Agreement No: WQSWCAP-2527-Summer-00183  
Project Title: 2025-2027 Biennial Stormwater Capacity Grant  
Recipient Name: City of Sumner

## 16. KICKBACKS

RECIPIENT is prohibited from inducing by any means any person employed or otherwise involved in this Agreement to give up any part of the compensation to which he/she is otherwise entitled to or receive any fee, commission, or gift in return for award of a subcontract hereunder.

## 17. MINORITY AND WOMEN'S BUSINESS ENTERPRISES (MWBE)

RECIPIENT is encouraged to solicit and recruit, to the extent possible, certified minority-owned (MBE) and women-owned (WBE) businesses in purchases and contracts initiated under this Agreement.

Contract awards or rejections cannot be made based on MWBE participation; however, the RECIPIENT is encouraged to take the following actions, when possible, in any procurement under this Agreement:

- a) Include qualified minority and women's businesses on solicitation lists whenever they are potential sources of goods or services.
- b) Divide the total requirements, when economically feasible, into smaller tasks or quantities, to permit maximum participation by qualified minority and women's businesses.
- c) Establish delivery schedules, where work requirements permit, which will encourage participation of qualified minority and women's businesses.
- d) Use the services and assistance of the Washington State Office of Minority and Women's Business Enterprises (OMWBE) (866-208-1064) and the Office of Minority Business Enterprises of the U.S. Department of Commerce, as appropriate.

## 18. ORDER OF PRECEDENCE

In the event of inconsistency in this Agreement, unless otherwise provided herein, the inconsistency shall be resolved by giving precedence in the following order: (a) applicable federal and state statutes and regulations; (b) The Agreement; (c) Scope of Work; (d) Special Terms and Conditions; (e) Any provisions or terms incorporated herein by reference, including the "Administrative Requirements for Recipients of Ecology Grants and Loans"; (f) Ecology Funding Program Guidelines; and (g) General Terms and Conditions.

## 19. PRESENTATION AND PROMOTIONAL MATERIALS

ECOLOGY reserves the right to approve RECIPIENT's communication documents and materials related to the fulfillment of this Agreement:

- a) If requested, RECIPIENT shall provide a draft copy to ECOLOGY for review and approval ten (10) business days prior to production and distribution.
- b) RECIPIENT shall include time for ECOLOGY's review and approval process in their project timeline.
- c) If requested, RECIPIENT shall provide ECOLOGY two (2) final copies and an electronic copy of any tangible products developed.

Copies include any printed materials, and all tangible products developed such as brochures, manuals, pamphlets, videos, audio tapes, CDs, curriculum, posters, media announcements, or gadgets with a message, such as a refrigerator magnet, and any online communications, such as web pages, blogs, and twitter campaigns. If it is not practical to provide a copy, then the RECIPIENT shall provide a description (photographs, drawings, printouts, etc.) that best represents the item.

Any communications intended for public distribution that uses ECOLOGY's logo shall comply with ECOLOGY's graphic requirements and any additional requirements specified in this Agreement. Before the use of ECOLOGY's logo contact ECOLOGY for guidelines.

RECIPIENT shall acknowledge in the communications that funding was provided by ECOLOGY.

## 20. PROGRESS REPORTING

- a) RECIPIENT must satisfactorily demonstrate the timely use of funds by submitting payment requests and progress

Agreement No: WQSWCAP-2527-Summer-00183  
Project Title: 2025-2027 Biennial Stormwater Capacity Grant  
Recipient Name: City of Sumner

reports to ECOLOGY. ECOLOGY reserves the right to amend or terminate this Agreement if the RECIPIENT does not document timely use of funds.

b) RECIPIENT must submit a progress report with each payment request. Payment requests will not be processed without a progress report. ECOLOGY will define the elements and frequency of progress reports.

c) RECIPIENT shall use ECOLOGY's provided progress report format.

d) Quarterly progress reports will cover the periods from January 1 through March 31, April 1 through June 30, July 1 through September 30, and October 1 through December 31. Reports shall be submitted within thirty (30) days after the end of the quarter being reported.

e) RECIPIENT must submit within thirty (30) days of the expiration date of the project, unless an extension has been approved by ECOLOGY, all financial, performance, and other reports required by the Agreement and funding program guidelines. RECIPIENT shall use the ECOLOGY provided closeout report format.

## 21. PROPERTY RIGHTS

a) Copyrights and Patents. When the RECIPIENT creates any copyrightable materials or invents any patentable property under this Agreement, the RECIPIENT may copyright or patent the same but ECOLOGY retains a royalty free, nonexclusive, and irrevocable license to reproduce, publish, recover, or otherwise use the material(s) or property, and to authorize others to use the same for federal, state, or local government purposes.

b) Publications. When the RECIPIENT or persons employed by the RECIPIENT use or publish ECOLOGY information; present papers, lectures, or seminars involving information supplied by ECOLOGY; or use logos, reports, maps, or other data in printed reports, signs, brochures, pamphlets, etc., appropriate credit shall be given to ECOLOGY.

c) Presentation and Promotional Materials. ECOLOGY shall have the right to use or reproduce any printed or graphic materials produced in fulfillment of this Agreement, in any manner ECOLOGY deems appropriate. ECOLOGY shall acknowledge the RECIPIENT as the sole copyright owner in every use or reproduction of the materials.

d) Tangible Property Rights. ECOLOGY's current edition of "Administrative Requirements for Recipients of Ecology Grants and Loans," shall control the use and disposition of all real and personal property purchased wholly or in part with funds furnished by ECOLOGY in the absence of state and federal statutes, regulations, or policies to the contrary, or upon specific instructions with respect thereto in this Agreement.

e) Personal Property Furnished by ECOLOGY. When ECOLOGY provides personal property directly to the RECIPIENT for use in performance of the project, it shall be returned to ECOLOGY prior to final payment by ECOLOGY. If said property is lost, stolen, or damaged while in the RECIPIENT's possession, then ECOLOGY shall be reimbursed in cash or by setoff by the RECIPIENT for the fair market value of such property.

f) Acquisition Projects. The following provisions shall apply if the project covered by this Agreement includes funds for the acquisition of land or facilities:

1. RECIPIENT shall establish that the cost is fair value and reasonable prior to disbursement of funds provided for in this Agreement.

2. RECIPIENT shall provide satisfactory evidence of title or ability to acquire title for each parcel prior to disbursement of funds provided by this Agreement. Such evidence may include title insurance policies, Torrens certificates, or abstracts, and attorney's opinions establishing that the land is free from any impediment, lien, or claim which would impair the uses intended by this Agreement.

g) Conversions. Regardless of the Agreement expiration date, the RECIPIENT shall not at any time convert any equipment, property, or facility acquired or developed under this Agreement to uses other than those for which assistance was originally approved without prior written approval of ECOLOGY. Such approval may be conditioned upon payment to ECOLOGY of that portion of the proceeds of the sale, lease, or other conversion or encumbrance which monies granted pursuant to this Agreement bear to the total acquisition, purchase, or construction costs of such property.

## 22. RECORDS, AUDITS, AND INSPECTIONS

Agreement No: WQSWCAP-2527-Summer-00183  
Project Title: 2025-2027 Biennial Stormwater Capacity Grant  
Recipient Name: City of Sumner

RECIPIENT shall maintain complete program and financial records relating to this Agreement, including any engineering documentation and field inspection reports of all construction work accomplished.

All records shall:

- a) Be kept in a manner which provides an audit trail for all expenditures.
- b) Be kept in a common file to facilitate audits and inspections.
- c) Clearly indicate total receipts and expenditures related to this Agreement.
- d) Be open for audit or inspection by ECOLOGY, or by any duly authorized audit representative of the State of Washington, for a period of at least three (3) years after the final grant payment or loan repayment, or any dispute resolution hereunder.

RECIPIENT shall provide clarification and make necessary adjustments if any audits or inspections identify discrepancies in the records.

ECOLOGY reserves the right to audit, or have a designated third party audit, applicable records to ensure that the state has been properly invoiced. Any remedies and penalties allowed by law to recover monies determined owed will be enforced. Repetitive instances of incorrect invoicing or inadequate records may be considered cause for termination.

All work performed under this Agreement and any property and equipment purchased shall be made available to ECOLOGY and to any authorized state, federal or local representative for inspection at any time during the course of this Agreement and for at least three (3) years following grant or loan termination or dispute resolution hereunder.

RECIPIENT shall provide right of access to ECOLOGY, or any other authorized representative, at all reasonable times, in order to monitor and evaluate performance, compliance, and any other conditions under this Agreement.

### 23. RECOVERY OF FUNDS

The right of the RECIPIENT to retain monies received as reimbursement payments is contingent upon satisfactory performance of this Agreement and completion of the work described in the Scope of Work.

All payments to the RECIPIENT are subject to approval and audit by ECOLOGY, and any unauthorized expenditure(s) or unallowable cost charged to this Agreement shall be refunded to ECOLOGY by the RECIPIENT.

RECIPIENT shall refund to ECOLOGY the full amount of any erroneous payment or overpayment under this Agreement.

RECIPIENT shall refund by check payable to ECOLOGY the amount of any such reduction of payments or repayments within thirty (30) days of a written notice. Interest will accrue at the rate of twelve percent (12%) per year from the time ECOLOGY demands repayment of funds.

Any property acquired under this Agreement, at the option of ECOLOGY, may become ECOLOGY's property and the RECIPIENT's liability to repay monies will be reduced by an amount reflecting the fair value of such property.

### 24. SEVERABILITY

If any provision of this Agreement or any provision of any document incorporated by reference shall be held invalid, such invalidity shall not affect the other provisions of this Agreement which can be given effect without the invalid provision, and to this end the provisions of this Agreement are declared to be severable.

### 25. STATE ENVIRONMENTAL POLICY ACT (SEPA)

RECIPIENT must demonstrate to ECOLOGY's satisfaction that compliance with the requirements of the State Environmental Policy Act (Chapter 43.21C RCW and Chapter 197-11 WAC) have been or will be met. Any reimbursements are subject to this provision.

### 26. SUSPENSION

When in the best interest of ECOLOGY, ECOLOGY may at any time, and without cause, suspend this Agreement or any portion thereof for a temporary period by written notice from ECOLOGY to the RECIPIENT. RECIPIENT shall resume performance on the next business day following the suspension period unless another day is specified by ECOLOGY.

Agreement No: WQSWCAP-2527-Summer-00183  
Project Title: 2025-2027 Biennial Stormwater Capacity Grant  
Recipient Name: City of Sumner

## 27. SUSTAINABLE PRACTICES

In order to sustain Washington's natural resources and ecosystems, the RECIPIENT is fully encouraged to implement sustainable practices and to purchase environmentally preferable products under this Agreement.

a) Sustainable practices may include such activities as: use of clean energy, use of double-sided printing, hosting low impact meetings, and setting up recycling and composting programs.

b) Purchasing may include such items as: sustainably produced products and services, EPEAT registered computers and imaging equipment, independently certified green cleaning products, remanufactured toner cartridges, products with reduced packaging, office products that are refillable, rechargeable, and recyclable, 100% post-consumer recycled paper, and toxic free products.

For more suggestions visit ECOLOGY's web page, Green Purchasing,

<https://ecology.wa.gov/Regulations-Permits/Guidance-technical-assistance/Sustainable-purchasing>.

## 28. TERMINATION

### a) For Cause

ECOLOGY may terminate for cause this Agreement with a seven (7) calendar days prior written notification to the RECIPIENT, at the sole discretion of ECOLOGY, for failing to perform an Agreement requirement or for a material breach of any term or condition. If this Agreement is so terminated, the parties shall be liable only for performance rendered or costs incurred in accordance with the terms of this Agreement prior to the effective date of termination.

**Failure to Commence Work.** ECOLOGY reserves the right to terminate this Agreement if RECIPIENT fails to commence work on the project funded within four (4) months after the effective date of this Agreement, or by any date mutually agreed upon in writing for commencement of work, or the time period defined within the Scope of Work.

**Non-Performance.** The obligation of ECOLOGY to the RECIPIENT is contingent upon satisfactory performance by the RECIPIENT of all of its obligations under this Agreement. In the event the RECIPIENT unjustifiably fails, in the opinion of ECOLOGY, to perform any obligation required of it by this Agreement, ECOLOGY may refuse to pay any further funds, terminate in whole or in part this Agreement, and exercise any other rights under this Agreement.

Despite the above, the RECIPIENT shall not be relieved of any liability to ECOLOGY for damages sustained by ECOLOGY and the State of Washington because of any breach of this Agreement by the RECIPIENT. ECOLOGY may withhold payments for the purpose of setoff until such time as the exact amount of damages due ECOLOGY from the RECIPIENT is determined.

### b) For Convenience

ECOLOGY may terminate for convenience this Agreement, in whole or in part, for any reason when it is the best interest of ECOLOGY, with a thirty (30) calendar days prior written notification to the RECIPIENT, except as noted below. If this Agreement is so terminated, the parties shall be liable only for performance rendered or costs incurred in accordance with the terms of this Agreement prior to the effective date of termination.

**Non-Allocation of Funds.** ECOLOGY's ability to make payments is contingent on availability of funding. In the event funding from state, federal or other sources is withdrawn, reduced, or limited in any way after the effective date and prior to the completion or expiration date of this Agreement, ECOLOGY, at its sole discretion, may elect to terminate the Agreement, in whole or part, or renegotiate the Agreement, subject to new funding limitations or conditions.

ECOLOGY may also elect to suspend performance of the Agreement until ECOLOGY determines the funding insufficiency is resolved. ECOLOGY may exercise any of these options with no notification or restrictions, although ECOLOGY will make a reasonable attempt to provide notice.

In the event of termination or suspension, ECOLOGY will reimburse eligible costs incurred by the RECIPIENT through the effective date of termination or suspension. Reimbursed costs must be agreed to by ECOLOGY and the RECIPIENT. In no event shall ECOLOGY's reimbursement exceed ECOLOGY's total responsibility under the Agreement and any amendments.

Agreement No: WQSWCAP-2527-Sumner-00183  
Project Title: 2025-2027 Biennial Stormwater Capacity Grant  
Recipient Name: City of Sumner

If payments have been discontinued by ECOLOGY due to unavailable funds, the RECIPIENT shall not be obligated to repay monies which had been paid to the RECIPIENT prior to such termination.

RECIPIENT's obligation to continue or complete the work described in this Agreement shall be contingent upon availability of funds by the RECIPIENT's governing body.

c) By Mutual Agreement

ECOLOGY and the RECIPIENT may terminate this Agreement, in whole or in part, at any time, by mutual written agreement.

d) In Event of Termination

All finished or unfinished documents, data studies, surveys, drawings, maps, models, photographs, reports or other materials prepared by the RECIPIENT under this Agreement, at the option of ECOLOGY, will become property of ECOLOGY and the RECIPIENT shall be entitled to receive just and equitable compensation for any satisfactory work completed on such documents and other materials.

Nothing contained herein shall preclude ECOLOGY from demanding repayment of all funds paid to the RECIPIENT in accordance with Recovery of Funds, identified herein.

29. THIRD PARTY BENEFICIARY

RECIPIENT shall ensure that in all subcontracts entered into by the RECIPIENT pursuant to this Agreement, the state of Washington is named as an express third party beneficiary of such subcontracts with full rights as such.

30. WAIVER

Waiver of a default or breach of any provision of this Agreement is not a waiver of any subsequent default or breach, and will not be construed as a modification of the terms of this Agreement unless stated as such in writing by the authorized representative of ECOLOGY.

End of General Terms and Conditions

---

**SUBJECT:** Fryar Ave Trail Project Property Acquisition - Roman 1, LLC

**CATEGORY:** Consent

---

**BUDGET IMPACT:**

Expenditure Required: \$400,000.00

Within Budget Allocation: Yes

---

**ATTACHMENTS:**

1. Property Acquisition Documents - Roman 1, LLC

**STAFF CONTACT:** Andrew Leach, Senior Associate City Engineer

---

**SUMMARY BACKGROUND:**

The Fryar Trail Project will construct approximately 3,300 linear feet of shared use path that parallels Fryar Avenue from West Main Street to Puyallup Street. In order to construct the project, partial acquisitions and/or easements are needed from twenty-three parcels along the project corridor. These twenty-three parcels are owned by thirteen different property owners. The City of Sumner was awarded \$655,143 in Federal CMAQ funding for right of way purchases and \$5,000,000 in WSDOT Pedestrian & Bicycle Safety Program state funds for completing the design, right of way, and construction of the project.

As part of the anticipated Fryar Avenue Trail project, the City is currently in the property acquisition phase. Roman 1, LLC is a property owner within the project footprint. Roman 1 is willingly conveying the necessary property to the City for the project, for an agreed-upon price of \$400,000.00. This project is grant funded and this acquisition was negotiated with the assistance of the City's consultant, Commonstreet in accordance with all applicable laws.

---

**COUNCIL COMMITTEE/STUDY SESSION:** Public Works Committee



**MEETING/STUDY SESSION DATE:** 4/21/2026

**COMMITTEE RECOMMENDATION:** Do Pass

**STAFF RECOMMENDATIONS/MOTION:**

Motion authorizing the negotiated purchase of property from Roman 1, LLC for purposes of constructing the Fryar Avenue Trail project for \$400,000.00 and authorizing Mayor to execute any and all documents necessary to effectuate the purchase in a form as approved by the City Attorney.

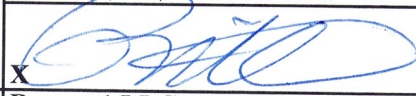
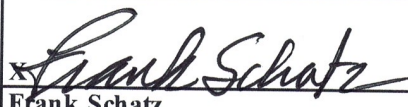
## REAL PROPERTY VOUCHER

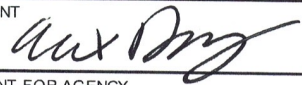
<b>AGENCY NAME</b>  <b>City of Sumner</b> 1104 Maple Street Sumner, WA 98390		I hereby certify under penalty of perjury that the items and amounts listed herein are proper charges against the Agency, that the same or any part thereof has not been paid, and that I am authorized to sign for the claimant.	
		SIGNATURE (INITIAL) FOR EACH CLAIMANT X 	DATED 4/10/2026
<b>GRANTOR OR CLAIMANT (NAME, ADDRESS)</b> <b>Frank and Linda Schatz</b> <b>Roman 1, LLC</b> 910 Traffic Avenue Sumner, WA 98390		<b>Roman 1 LLC</b> <b>Philip L. Mitchell, Manager</b>	
<b>PROJECT NO. AND TITLE</b> <b>Fryar Avenue Shared Use Trail</b> <b>A15.0029</b>		X  <b>Frank Schatz</b>	
<b>FEDERAL AID NO.</b> <b>TAP 1270(012)</b>	<b>PARCEL NO.</b> <b>0420243057</b>	X  <b>Linda Schatz</b>	
In full, complete and final payment and settlement for the title or interest conveyed or released, as fully set forth in:		DATED 4/15/26	\$ AMOUNT
Warranty Deed, Slope Easement		+	\$218,200.00
<b>LAND:</b> Fee Acquisition: 4,847 SF		+	\$127,100.00
Slope Easement: 3,766 SF		+	
<b>IMPROVEMENTS:</b>		+	
<b>DAMAGES:</b>		+	
Cost to Cure		+	
Proximity		+	
Other		+	
<b>SPECIAL BENEFITS</b>			
<b>JC (Just Compensation) Amount</b>			<b>\$345,300.00</b>
<b>REMAINDER:</b>			
Uneconomic Remnant		+	
Excess Acquisition		+	
<b>ADMINISTRATIVE SETTLEMENT</b>		+	<b>\$54,700.00</b>
<b>STATUTORY EVALUATION ALLOWANCE</b>		+	
<b>ESCROW FEE</b>		+	
<b>REAL ESTATE EXCISE TAX</b>		+	
<b>OTHER:</b>		+	
<b>ACQUISITION AGENT</b> 		DATE 4/15/26	Voucher No.
<b>AUTHORIZED AGENT FOR AGENCY</b>		DATE	<b>TOTAL AMOUNT PAID</b> <b>\$400,000.00</b>

After recording return document to:

City of Sumner  
1104 Maple Street  
Sumner, WA 98390

**Document Title: Slope Easement**  
**Grantors: Frank A. Schatz and Linda L. Schatz, Roman 1, LLC**  
**Grantee: City of Sumner**  
**Legal Description: Ptn. SW S-T-R 24-20-4**  
**Additional Legal Description is on Page 5 of the Document**  
**Assessor's Tax Parcel Number: Ptn. 0420243057**

## SLOPE EASEMENT

### CITY OF SUMNER FRYAR AVENUE SHARED USE TRAIL

The Grantors, Frank A. Schatz and Linda L. Schatz, husband and wife, and Roman 1, LLC, a limited liability company, for and in consideration of the sum of TEN AND NO/100 (\$10.00) Dollars, and other valuable consideration, hereby convey(s) and grant(s) unto the City of Sumner and its assigns, Grantee, under the imminent threat of the Grantee's exercise of its rights of Eminent Domain, a permanent non-exclusive easement over, across, along, in, upon and under the hereinafter described lands for the purpose of the Fryar Avenue Shared Use Trail project, including but not limited to installing, constructing, accessing, maintaining, removing, repairing, and replacing slopes and/or slope cuts, together with all connections, and appurtenances thereto, together with the right of ingress to and egress from said described property for the foregoing purposes.

Said lands being situated in Pierce County, State of Washington, and described as follows:

For legal description and additional conditions  
See Exhibit A and B attached hereto and made a part hereof

It is understood and agreed that delivery of this easement is hereby tendered and that the terms and obligations hereof shall not become binding upon the **City of Sumner** unless and until accepted and approved hereon in writing for the **City of Sumner**, by its authorized agent.

**EASEMENT**

Date: April 15, 2026

Frank A. Schatz  
Frank A. Schatz

Linda L. Schatz  
Linda L. Schatz

Roman 1 LLC, a Washington limited liability company

By:   
Philip L. Mitchell, Manager

Accepted and Approved  
City of Sumner  
By: \_\_\_\_\_  
Kathy Hayden  
Mayor of the City of Sumner

Date: \_\_\_\_\_

**EASEMENT**

**ACKNOWLEDGMENT  
(Individual)**

STATE OF WASHINGTON )  
  )  
County of Pierce )

I certify that I know or have satisfactory evidence that Frank A. Schatz and Linda L. Schatz are the persons who appeared before me, and that said persons acknowledged that they signed this instrument and acknowledged it to be their free and voluntary act for the uses and purposes mentioned in the instrument.

DATED this 15 day of April, 2026.

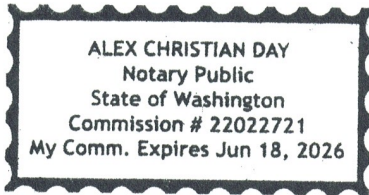

Alex Day  
(Print Name)  
[Signature]  
Notary Public in and for the State of Washington  
Residing at Shoreline

My Appointment Expires:  
6/18/2026

EASEMENT

ACKNOWLEDGMENT  
(Limited Liability Company)

STATE OF WASHINGTON )  
 )  
County of Pierce )

I certify that I know or have satisfactory evidence that Philip L. Mitchell is the person who appeared before me, and said person acknowledged he signed this instrument, on oath stated that he was authorized to execute the instrument and acknowledged it as the Manager of Roman 1, LLC, a Limited Liability Company, to be the free and voluntary act of such party for the uses and purposes mentioned in the instrument

DATED this 10 day of April, 2026.



Marcia K Bowlin  
(Print Name)

Marcia K. Bowlin  
Notary Public in and for the State of Washington  
Residing at Puyallup, WA

My Appointment Expires:  
11-29-29

**EXHIBIT A**  
**PARCEL NO. 0420243057**  
**SLOPE EASEMENT**

THAT PORTION OF THE HEREINAFTER DESCRIBED PARCEL "A", DESCRIBED AS FOLLOWS:

BEGINNING AT A POINT OPPOSITE STATION R<sub>w</sub>L 10+28.05, AS SHOWN ON CITY OF SUMNER "FRYAR AVENUE SHARED USE TRAIL RIGHT OF WAY PLANS" ON FILE WITH THE CITY, 13.00 FEET EASTERLY THEREFROM;

THENCE NORTHWESTERLY IN A STRAIGHT LINE TO A POINT OPPOSITE STATION 11+14.20, 13.00 FEET NORTHEASTERLY THEREFROM;

THENCE NORTHERLY IN A STRAIGHT LINE TO A POINT OPPOSITE STATION 11+79.00, 14.58 FEET SOUTHEASTERLY THEREFROM;

THENCE NORTHEASTERLY IN A STRAIGHT LINE TO A POINT OPPOSITE STATION 12+17.50, 17.77 FEET SOUTHEASTERLY THEREFROM;

THENCE NORTHEASTERLY IN A STRAIGHT LINE TO A POINT OPPOSITE STATION 12+43.00, 14.33 FEET SOUTHEASTERLY THEREFROM;

THENCE NORTHEASTERLY IN A STRAIGHT LINE TO A POINT OPPOSITE STATION 12+65.69, 27.44 FEET SOUTHEASTERLY THEREFROM;

THENCE SOUTHEASTERLY IN A STRAIGHT LINE TO A POINT OPPOSITE STATION 12+62.52, 44.45 FEET SOUTHEASTERLY THEREFROM;

THENCE EASTERLY IN A STRAIGHT LINE TO A POINT OPPOSITE STATION 12+63.70, 50.14 FEET SOUTHEASTERLY THEREFROM;

THENCE SOUTHWESTERLY IN A STRAIGHT LINE TO A POINT OPPOSITE STATION 12+27.48, 48.48 FEET SOUTHEASTERLY THEREFROM;

THENCE SOUTHWESTERLY IN A STRAIGHT LINE TO A POINT OPPOSITE STATION 11+84.20, 28.31 FEET SOUTHEASTERLY THEREFROM;

THENCE SOUTHEASTERLY IN A STRAIGHT LINE TO A POINT OPPOSITE STATION 10+27.63, 15.19 FEET EASTERLY THEREFROM;

THENCE SOUTHWESTERLY IN A STRAIGHT LINE TO THE POINT OF BEGINNING.

CONTAINING 3,766 SQUARE FEET, MORE OR LESS.

TRACT:

(PER CHICAGO TITLE COMPANY ORDER NO. 242491, DATED JULY 18, 2024)

PARCEL A:

COMMENCING AT THE INTERSECTION OF THE NORTH LINE OF MAIN STREET IN THE TOWN OF SUMNER, WASHINGTON, WITH THE EAST LINE OF THE STUCK VALLEY COUNTY ROAD, THAT POINT BEING 30.4 FEET NORTH 32°30' WEST AND 30.4 FEET NORTH 68°22' EAST OF A STONE MONUMENT THAT MARKS THE JUNCTION OF THE STUCK VALLEY COUNTY ROAD WITH MAIN STREET IN THE TOWN OF SUMNER, NEAR

1-SLOPE.DOCX

THE WEST BOUNDARY OF THE W.M. KINCAID DONATION LAND CLAIM IN SECTION 24, TOWNSHIP 20 NORTH, RANGE 4 EAST OF THE W.M., IN PIERCE COUNTY, WASHINGTON;  
THENCE NORTH 32°30' WEST ALONG THE EAST BOUNDARY OF SAID COUNTY ROAD 140 FEET;  
THENCE NORTH 46°38' EAST 117 FEET;  
THENCE SOUTH 32°30' EAST 184 FEET TO THE NORTH BOUNDARY OF MAIN STREET IN THE TOWN OF SUMNER;  
THENCE SOUTH 68°22' WEST ALONG THE NORTH BOUNDARY OF SAID MAIN STREET 117 FEET TO THE PLACE OF BEGINNING;  
EXCEPT THAT PORTION THEREOF CONVEYED TO THE CITY OF SUMNER BY DEED RECORDED UNDER RECORDING NUMBER 201701100612.

10/18/24



SW 1/4, SEC. 24, T. 20 N., R. 4 E., W.M.

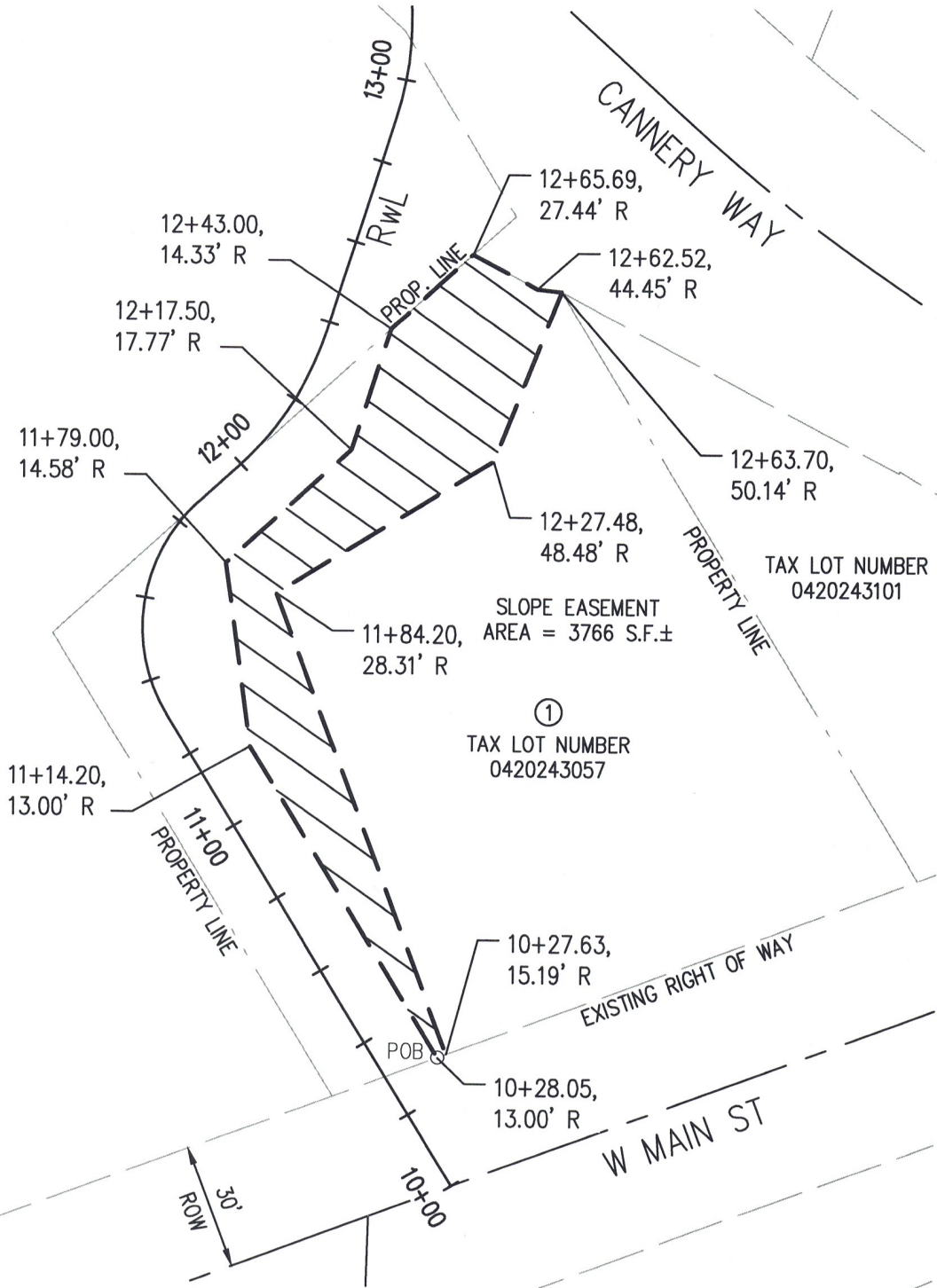

DATE: OCTOBER 18, 2024

FILE: 1.DWG

**KPG**  
PSOMAS

Seattle  
3131 Elliott Avenue, Suite 400  
Seattle, WA 98121 206.286.1640  
Tacoma | Wenatchee | KPG.com

EXHIBIT B  
PARCEL 0420243057  
SLOPE EASEMENT

After recording return document to:

City of Sumner  
1104 Maple Street  
Sumner, WA 98390

**Document Title: Warranty Deed**  
**Grantors: Frank A. Schatz and Linda L. Schatz, Roman 1, LLC**  
**Grantee: City of Sumner**  
**Legal Description: Ptn. SW S-T-R 24-20-4**  
**Additional Legal Description is on Page 5 of Document**  
**Assessor's Tax Parcel Number: Ptn. 0420243057**

## WARRANTY DEED

### CITY OF SUMNER FRYAR AVENUE SHARED USE TRAIL

The Grantors, Frank A. Schatz and Linda L. Schatz, husband and wife, and Roman 1, LLC, a limited liability company, for and in consideration of the sum of TEN AND NO/100 (\$10.00) Dollars, and other valuable consideration, hereby convey(s) and warrant(s) to the City of Sumner, Grantee, the following described real property situated in Pierce County, in the State of Washington, under the imminent threat of the Grantee's exercise of its rights of Eminent Domain, together with any after acquired interest of the grantor:

For legal description and additional conditions  
See Exhibit A and B attached hereto and made a part hereof.

Also, the undersigned hereby requests the Assessor and Treasurer of said County to set over to the remainder of the herein described Parcel "A" the lien of all unpaid taxes, if any, affecting the property hereby conveyed, as provided by RCW 84.60.070.

It is understood and agreed that delivery of this deed is hereby tendered and that the terms and obligations hereof shall not become binding upon the City of Sumner unless and until accepted and approved hereon in writing for the City of Sumner, by its authorized agent.

**WARRANTY DEED**

Date: April 15, 2026

Frank A. Schatz  
Frank A. Schatz

Linda L. Schatz  
Linda L. Schatz

Roman 1 LLC, a Washington limited liability company

By: [Signature]

Philip L. Mitchell, Manager

Accepted and Approved

City of Sumner

By: \_\_\_\_\_  
Kathy Hayden  
Mayor of the City of Sumner

Date: \_\_\_\_\_

**WARRANTY DEED**

**ACKNOWLEDGMENT  
(Individual)**

STATE OF WASHINGTON )  
 )  
County of Pierce )

I certify that I know or have satisfactory evidence that Frank A. Schatz and Linda L. Schatz are the persons who appeared before me, and that said persons acknowledged that they signed this instrument and acknowledged it to be their free and voluntary act for the uses and purposes mentioned in the instrument.

DATED this 15 day of April, 2026.

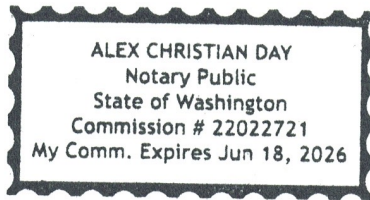

Alex Day  
(Print Name)

[Signature]  
Notary Public in and for the State of Washington  
Residing at Shoreline

My Appointment Expires:  
6/18/2026

**WARRANTY DEED**

**ACKNOWLEDGMENT  
(Limited Liability Company)**

STATE OF WASHINGTON    )  
  )  
County of Pierce         )

I certify that I know or have satisfactory evidence that Philip L. Mitchell is the person who appeared before me, and said person acknowledged he signed this instrument, on oath stated that he was authorized to execute the instrument and acknowledged it as the Manager of Roman 1, LLC, a Limited Liability Company, to be the free and voluntary act of such party for the uses and purposes mentioned in the instrument.

DATED this 10 day of April, 2026.



Marcia K Bowlm  
(Print Name)

Marcia K. Bowlm  
Notary Public in and for the State of Washington  
Residing at Puyallup, WA

My Appointment Expires:  
11-29-29

**EXHIBIT A**  
**PARCEL NO. 0420243057**  
**RIGHT OF WAY ACQUISITION**

THAT PORTION OF THE HEREINAFTER DESCRIBED PARCEL "A", LYING SOUTHWESTERLY, WESTERLY, AND NORTHWESTERLY OF THE FOLLOWING DESCRIBED LINE:

BEGINNING AT A POINT OPPOSITE STATION R<sub>w</sub>L 10+28.05, AS SHOWN ON CITY OF SUMNER "FRYAR AVENUE SHARED USE TRAIL RIGHT OF WAY PLANS" ON FILE WITH THE CITY, 13.00 FEET NORTHEASTERLY THEREFROM;

THENCE NORTHWESTERLY IN A STRAIGHT LINE TO A POINT OPPOSITE STATION 11+14.20, 13.00 FEET NORTHEASTERLY THEREFROM;

THENCE NORTHERLY IN A STRAIGHT LINE TO A POINT OPPOSITE STATION 11+79.00, 14.58 FEET SOUTHEASTERLY THEREFROM;

THENCE NORTHEASTERLY IN A STRAIGHT LINE TO A POINT OPPOSITE STATION 12+17.50, 17.77 FEET SOUTHEASTERLY THEREFROM;

THENCE NORTHEASTERLY IN A STRAIGHT LINE TO A POINT OPPOSITE STATION 12+43.00, 14.33 FEET SOUTHEASTERLY THEREFROM AND THE TERMINUS OF SAID DESCRIBED LINE.

CONTAINING 4,847 SQUARE FEET, MORE OR LESS.

**TRACT:**

(PER CHICAGO TITLE COMPANY ORDER NO. 242491, DATED JULY 18, 2024)

**PARCEL A:**

COMMENCING AT THE INTERSECTION OF THE NORTH LINE OF MAIN STREET IN THE TOWN OF SUMNER, WASHINGTON, WITH THE EAST LINE OF THE STUCK VALLEY COUNTY ROAD, THAT POINT BEING 30.4 FEET NORTH 32°30' WEST AND 30.4 FEET NORTH 68°22' EAST OF A STONE MONUMENT THAT MARKS THE JUNCTION OF THE STUCK VALLEY COUNTY ROAD WITH MAIN STREET IN THE TOWN OF SUMNER, NEAR THE WEST BOUNDARY OF THE W.M. KINCAID DONATION LAND CLAIM IN SECTION 24, TOWNSHIP 20 NORTH, RANGE 4 EAST OF THE W.M., IN PIERCE COUNTY, WASHINGTON;

THENCE NORTH 32°30' WEST ALONG THE EAST BOUNDARY OF SAID COUNTY ROAD 140 FEET;

THENCE NORTH 46°38' EAST 117 FEET;

THENCE SOUTH 32°30' EAST 184 FEET TO THE NORTH BOUNDARY OF MAIN STREET IN THE TOWN OF SUMNER;

THENCE SOUTH 68°22' WEST ALONG THE NORTH BOUNDARY OF SAID MAIN STREET 117 FEET TO THE PLACE OF BEGINNING;

EXCEPT THAT PORTION THEREOF CONVEYED TO THE CITY OF SUMNER BY DEED RECORDED UNDER RECORDING NUMBER 201701100612.

EXCEPT THAT PORTION THEREOF CONVEYED TO THE CITY OF SUMNER BY DEED RECORDED UNDER RECORDING NUMBER 9012070086, WHICH IS A RE-RECORDING OF RECORDING NUMBER 9012060261;

AND EXCEPT THAT PORTION THEREOF CONVEYED TO THE CITY OF SUMNER BY DEED RECORDED UNDER RECORDING NUMBER 200908180150;

1-ROW.DOCX

AND EXCEPT THAT PORTION THEREOF CONVEYED TO THE CITY OF SUMNER BY DEED RECORDED UNDER RECORDING NUMBER 201701100612.

09/24/24



SW 1/4, SEC. 24, T. 20 N., R. 4 E., W.M.

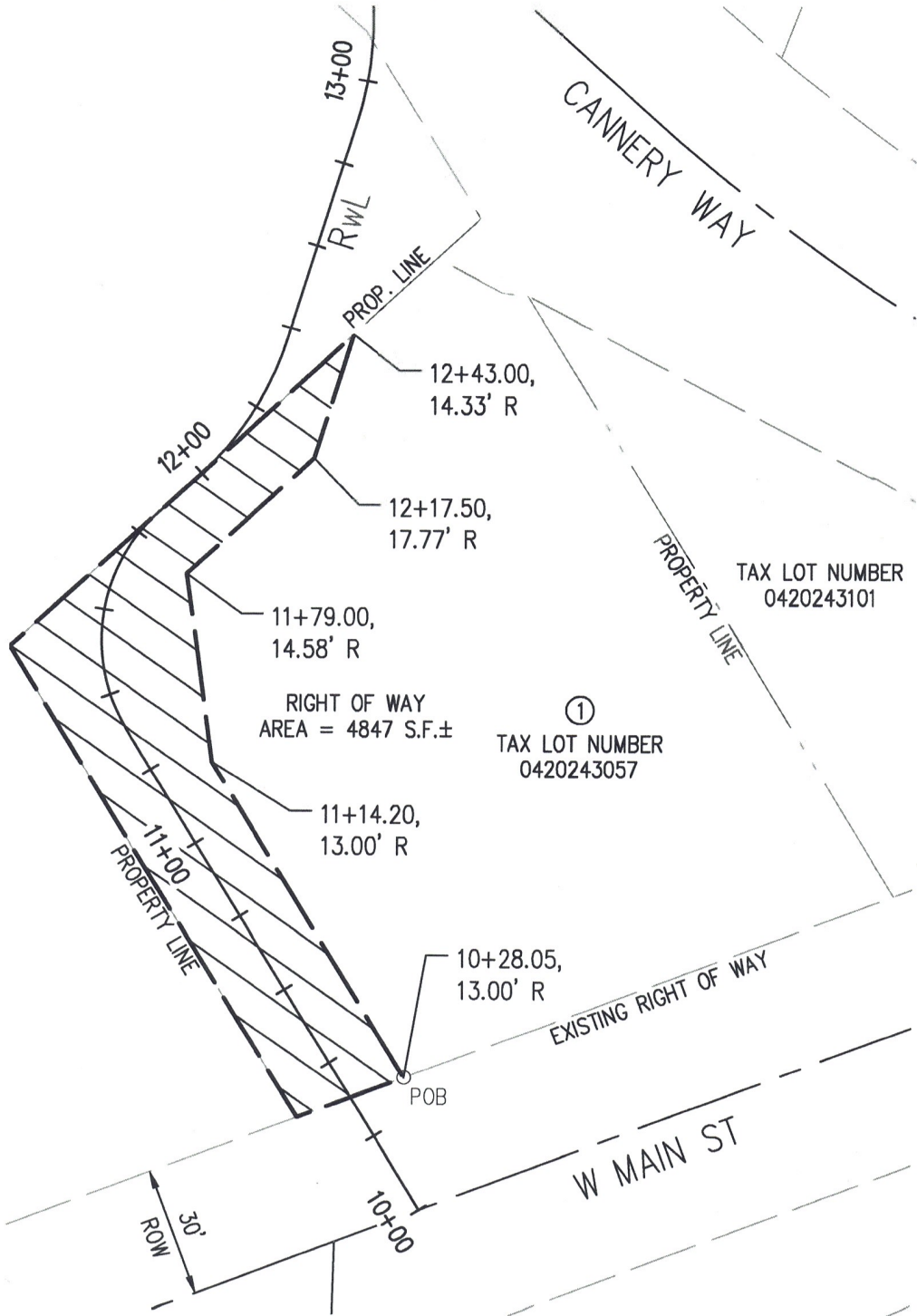

DATE: SEPTEMBER 4, 2024

FILE: 1.DWG

**KPG**  
**PSOMAS**  
 Seattle  
 3131 Elliott Avenue, Suite 400  
 Seattle, WA 98121 206.286.1640  
 Tacoma | Wenatchee | KPG.com

EXHIBIT B  
 PARCEL 0420243057  
 RIGHT OF WAY ACQUISITION

---

**SUBJECT:** Fryar Ave Trail Project Property Acquisition - Liberty Property Development Corp II

**CATEGORY:** Consent

---

**BUDGET IMPACT:**

Expenditure Required: \$131,373.23

Within Budget Allocation: Yes

---

**ATTACHMENTS:**

1. Property Acquisition Documents - Liberty Property Development Corp II

**STAFF CONTACT:** Andrew Leach, Senior Associate City Engineer

---

**SUMMARY BACKGROUND:**

The Fryar Trail Project will construct approximately 3,300 linear feet of shared use path that parallels Fryar Avenue from West Main Street to Puyallup Street. In order to construct the project, partial acquisitions and/or easements are needed from twenty-three parcels along the project corridor. These twenty-three parcels are owned by thirteen different property owners. The City of Sumner was awarded \$655,143 in Federal CMAQ funding for right of way purchases and \$5,000,000 in WSDOT Pedestrian & Bicycle Safety Program state funds for completing the design, right of way, and construction of the project.

As part of the anticipated Fryar Avenue Trail project, the City is currently in the property acquisition phase. Liberty Property Development Corp II is a property owner within the project footprint. Liberty Property is willingly conveying the necessary property to the City for the project, for an agreed-upon price of \$131,373.23. This project is grant funded and this acquisition was negotiated with the assistance of the City's consultant, Commonstreet in accordance with all applicable laws.



---

<p><b>COUNCIL COMMITTEE/STUDY SESSION:</b> Public Works Committee <b>MEETING/STUDY SESSION DATE:</b> 4/21/2026 <b>COMMITTEE RECOMMENDATION:</b> Do Pass</p>
---

**STAFF RECOMMENDATIONS/MOTION:**

Motion authorizing the negotiated purchase of property from Liberty Property Development Corp II for purposes of constructing the Fryar Avenue Trail project for \$131,373.23 and authorizing Mayor to execute any and all documents necessary to effectuate the purchase in a form as approved by the City Attorney.

**REAL PROPERTY VOUCHER**

<b>AGENCY NAME</b>  <b>City of Sumner</b> 1104 Maple Street Sumner, WA 98390		I hereby certify under penalty of perjury that the items and amounts listed herein are proper charges against the Agency, that the same or any part thereof has not been paid, and that I am authorized to sign for the claimant.					
		<table border="1" style="width:100%; border-collapse: collapse;"> <tr> <td style="width:80%; font-size: x-small;">SIGNATURE (IN INK) FOR EACH CLAIMANT</td> <td style="width:20%; font-size: x-small;">DATED</td> </tr> <tr> <td align="center" style="height: 40px;">  </td> <td></td> </tr> <tr> <td> <b>X</b>  <b>Name:</b> Heidi Seal  <b>Title:</b> Vice President                 </td> <td></td> </tr> </table>		SIGNATURE (IN INK) FOR EACH CLAIMANT	DATED		
SIGNATURE (IN INK) FOR EACH CLAIMANT	DATED						
							
<b>X</b> <b>Name:</b> Heidi Seal <b>Title:</b> Vice President							
<b>GRANTOR OR CLAIMANT (NAME, ADDRESS)</b> <b>Old Republic Title, Ltd.</b> 16040 Hewitt Avenue, Suite 701 Everett, WA 98201							
<b>PROJECT NO. AND TITLE</b> <b>Fryar Avenue Shared Use Trail</b> <b>A15.0029</b>							
FEDERAL AID NO.	PARCEL NO.						
<b>TAP 1270(012)</b>	<b>0420242057 &amp; 0420242032</b>						
In full, complete and final payment and settlement for the title or interest conveyed or released, as fully set forth in:		DATED	\$ AMOUNT				
Warranty deed, temporary easements, slope easement							
<b>LAND:</b>	<b>Fee Acquisition: 4,154 SF</b>	+	<b>\$87,300.00</b>				
	<b>Slope Easement: 490 SF</b>	+	<b>\$1,700.00</b>				
	<b>Temporary Easements: 517 SF total</b>	+	<b>\$7,700.00</b>				
<b>IMPROVEMENTS:</b>							
	<b>Asphalt, grass lawn, ivy</b>	+	<b>\$4,500.00</b>				
<b>DAMAGES:</b>							
	<b>Cost to Cure: sign and irrigation</b>	+	<b>\$6,300.00</b>				
	<b>Proximity</b>	+					
	<b>Other</b>	+					
<b>SPECIAL BENEFITS</b>							
<b>JC (Just Compensation) Amount</b>			<b>\$107,500.00</b>				
<b>REMAINDER:</b>							
	<b>Uneconomic Remnant</b>	+					
	<b>Excess Acquisition</b>	+					
<b>ADMINISTRATIVE SETTLEMENT</b>		+	<b>\$21,100.00</b>				
<b>STATUTORY EVALUATION ALLOWANCE</b>		+					
<b>ESCROW FEE</b>		+	<b>\$1,099.00</b>				
<b>REAL ESTATE EXCISE TAX</b>		+	<b>\$40.00</b>				
<b>OTHER:</b>							
Recording fees Special Warranty Deed: \$307.50; 3 easements at \$308.50 = 925.50			<b>\$1,233.00</b>				
Title fees		+	<b>\$401.23</b>				
ACQUISITION AGENT	DATE	Voucher No.	<b>TOTAL AMOUNT PAID</b>  <b>\$131,373.23</b>				
AUTHORIZED AGENT FOR AGENCY	DATE						

After recording return document to:

City of Sumner  
1104 Maple Street  
Sumner, WA 98390

**Document Title: Special Warranty Deed**  
**Reference Number of Related Document: N/A**  
**Grantor(s): Liberty Property Development Corp.-II**  
**Grantee(s): City of Sumner**  
**Legal Description: Ptn. NW S-T-R 24-20-4**  
**Additional Legal Description is on Pages 4 and 5 of Document.**  
**Assessor's Tax Parcel Number: 0420242032**

## **SPECIAL WARRANTY DEED**

CITY OF SUMNER FRYAR AVENUE SHARED USE TRAIL

The Grantor, Liberty Property Development Corp.- II, a Pennsylvania corporation, for and in consideration of the sum of TEN AND NO/100 (\$10.00) Dollars, and other valuable consideration in hand paid, grants, bargains, sells, conveys, and confirms to the City of Sumner, Grantee, the following described real property situated in Pierce County, in the State of Washington, under the imminent threat of the Grantee's exercise of its rights of Eminent Domain:

For legal description and depiction  
See Exhibits A and B attached hereto and made a part hereof.

Also, the undersigned hereby requests the Assessor and Treasurer of said County to set over to the remainder of the herein described Parcel "A" the lien of all unpaid taxes, if any, affecting the property hereby conveyed, as provided by RCW 84.60.070.

**SPECIAL WARRANTY DEED**

The Grantor, for itself and for its successors in interest do by these presents expressly limit the covenants of the deed to those herein expressed, and exclude all covenants arising or to arise by statutory or other implication, and does hereby covenant that against all persons whomsoever lawfully claiming or to claim by, through or under said Grantor and not otherwise, subject to the liens, encumbrances, exceptions and other matters of record.

It is understood and agreed that delivery of this deed is hereby tendered and that the terms and obligations hereof shall not become binding upon the City of Sumner unless and until accepted and approved hereon in writing for the City of Sumner by its authorized agent.

Date: \_\_\_\_\_ 20\_\_\_\_

Liberty Property Development Corp.- II,  
a Pennsylvania corporation

By:  \_\_\_\_\_  
Name: Heidi Seal  
Title: Vice President  
Title: \_\_\_\_\_

Accepted and Approved

City of Sumner

By: \_\_\_\_\_  
Kathy Hayden  
Mayor of the City of Sumner

Date: \_\_\_\_\_

**SPECIAL WARRANTY DEED**

STATE OF Colorado  
County of Denver

I certify that I know or have satisfactory evidence that Heidi Seal is the person who appeared before me, and said person acknowledged they signed this instrument, on oath stated that they were authorized to execute the instrument and acknowledged it as the Vice President of Liberty Property Development Corp.-II, a Pennsylvania corporation to be the free and voluntary act of such party for the uses and purposes mentioned in the instrument.

DATED this 15 day of April, 2024.

Tanya M. Young  
(Print Name)  
Tanya M. Young  
Notary Public in and for the State of Colorado  
Residing at Aurora, CO

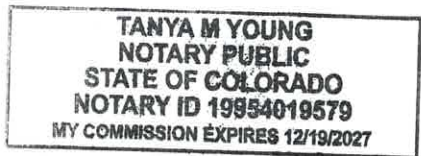

My Appointment Expires: 12-19-2027

**EXHIBIT A**  
**PARCEL NO. 0420242032**  
**RIGHT OF WAY ACQUISITION**

THAT PORTION OF THE HEREINAFTER DESCRIBED TRACT LYING EASTERLY OF THE FOLLOWING DESCRIBED LINE:

BEGINNING AT A POINT OPPOSITE STATION Rwf 34+13.98, AS SHOWN ON CITY OF SUMNER "FRYAR AVENUE SHARED USE TRAIL RIGHT OF WAY PLANS" ON FILE WITH THE CITY, 37.00 FEET WESTERLY THEREFROM;

THENCE SOUTHERLY IN A STRAIGHT LINE TO A POINT OPPOSITE STATION 33+42.50, 37.00 FEET WESTERLY THEREFROM;

THENCE SOUTHWESTERLY IN A STRAIGHT LINE TO A POINT OPPOSITE STATION 33+25.00, 48.00 FEET WESTERLY THEREFROM;

THENCE SOUTHERLY IN A STRAIGHT LINE TO A POINT OPPOSITE STATION 32+41.50, 48.00 FEET WESTERLY THEREFROM;

THENCE SOUTHEASTERLY IN A STRAIGHT LINE TO A POINT OPPOSITE STATION 32+23.75, 37.00 FEET WESTERLY THEREFROM;

THENCE SOUTHERLY IN A STRAIGHT LINE TO A POINT OPPOSITE STATION 29+79.48, 37.00 FEET WESTERLY THEREFROM AND THE TERMINUS OF SAID DESCRIBED LINE;

CONTAINING 4,154 SQUARE FEET, MORE OR LESS.

TRACT:

(PER CHICAGO TITLE COMPANY ORDER NO. 242507, DATED JULY 19, 2024)

BEGINNING ON THE SOUTH LINE OF THE CHICAGO, MILWAUKEE, ST. PAUL RAILROAD RIGHT OF WAY, AT THE INTERSECTION OF THE WEST LINE OF THE WILLIAMS COUNTY ROAD;  
THENCE SOUTH ON THE WEST LINE OF SAID ROAD 434 FEET;  
THENCE WEST AT RIGHT ANGLES TO WILLIAMS STREET TO THE CENTER LINE OF THE STUCK RIVER;  
THENCE NORTHERLY ALONG SAID CENTER LINE TO THE SOUTHERLY LINE OF THE CHICAGO, MILWAUKEE, ST. PAUL RAILWAY COMPANY SPUR RIGHT OF WAY;  
THENCE EAST ALONG SAID RIGHT OF WAY TO THE POINT OF BEGINNING;  
EXCEPT THAT PORTION THEREOF WITHIN THE BED OF THE STUCK RIVER;  
BEING A PORTION OF THE A. MORRISON DONATION LAND CLAIM IN SECTION 24, TOWNSHIP 20 NORTH, RANGE 4 EAST OF THE WILLAMETTE MERIDIAN, IN PIERCE COUNTY, WASHINGTON.

09/24/24



22-ROW.DOCX

Page 1 of 1

**KPG**  
TACOMA · SEATTLE

EXHIBIT B

NW 1/4, SEC. 24, T. 20 N., R. 4 E., W.M.

CHICAGO, MILWAUKEE & ST. PAUL RR

EXISTING RIGHT OF WAY

POB

34+13.98,  
37.00' L

33+42.50,  
37.00' L

33+25.00,  
48.00' L

RIGHT OF WAY  
AREA = 4154 S.F.±

22

TAX LOT NUMBER  
0420242032

32+41.50,  
48.00' L

32+23.75,  
37.00' L

34+00  
33+00  
32+00  
31+00  
30+00

30'  
ROW

RwF (FRYAR AVE)

PROPERTY LINE

TAX LOT NUMBER  
0420242057



N.T.S.

DATE: AUGUST 30, 2024

FILE: 22.DWG



Seattle  
3131 Elliott Avenue, Suite 400  
Seattle, WA 98121 206.286.1640  
Tacoma | Wenatchee | KPG.com

EXHIBIT B  
PARCEL 0420242032  
RIGHT OF WAY ACQUISITION

After recording return document to:

City of Sumner  
1104 Maple Street  
Sumner, WA 98390

**Document Title: Slope Easement**  
**Grantor: Liberty Property Development Corp.- II**  
**Grantee: City of Sumner**  
**Legal Description: Ptn. NW S-T-R 24-20-4**  
**Additional Legal Description is on Page 5 and 6 of Document.**  
**Assessor's Tax Parcel Number: 0420242032**

## **SLOPE EASEMENT**

### **CITY OF SUMNER FRYAR AVENUE SHARED USE TRAIL**

The Grantor(s), Liberty Property Development Corp.- II, a Pennsylvania corporation, for and in consideration of the sum of TEN AND NO/100 (\$10.00) Dollars, and other valuable consideration, hereby convey(s) and grant(s) unto the City of Sumner and its assigns, Grantee, under the imminent threat of the Grantee's exercise of its rights of Eminent Domain, a permanent non-exclusive easement over, across, along, in, upon and under the hereinafter described lands for the purpose of the Fryar Avenue Shared Use Trail project, including but not limited to installing, constructing, accessing, maintaining, removing, repairing, and replacing slopes and/or slope cuts, together with all connections, and appurtenances thereto, together with the right of ingress to and egress from said described property for the foregoing purposes.

Said lands being situated in Pierce County, State of Washington, and described as follows:

For legal description and additional conditions  
See Exhibit A and B attached hereto and made a part hereof

It is understood and agreed that delivery of this easement is hereby tendered and that the terms and obligations hereof shall not become binding upon the **City of Sumner** unless and until accepted and approved hereon in writing for the **City of Sumner**, by its authorized agent.

**SLOPE EASEMENT**

IN WITNESS WHEREOF, said corporation has caused this instrument to be executed by its proper officers this \_\_\_\_\_ day of \_\_\_\_\_, 20\_\_\_\_\_.

Liberty Property Development Corp.- II,  
a Pennsylvania corporation

By:  \_\_\_\_\_

Name: Heidi Seal

Title: Vice President

Accepted and Approved

City of Sumner

By: \_\_\_\_\_

Kathy Hayden  
Mayor of the City of Sumner

Date: \_\_\_\_\_

**SLOPE EASEMENT**

STATE OF Colorado )  
County of Denver }

I certify that I know or have satisfactory evidence that Heidi Seal is the person who appeared before me, and said person acknowledged they signed this instrument, on oath stated that they were authorized to execute the instrument and acknowledged it as the Vice President of Liberty Property Development Corp.-II, a Pennsylvania corporation to be the free and voluntary act of such party for the uses and purposes mentioned in the instrument.

DATED this 13 day of April, 2026.

Tanya M. Young  
(Print Name)  
Tanya M. Young  
Notary Public in and for the State of Colorado  
Residing at Aurora CO

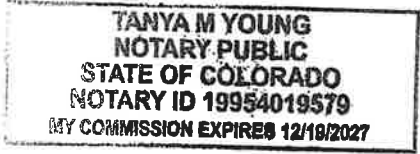

My Appointment Expires: 12/19/2027

**EXHIBIT A**  
**PARCEL NO. 0420242032**  
**SLOPE EASEMENT**

THAT PORTION OF THE HEREINAFTER DESCRIBED TRACT DESCRIBED AS FOLLOWS:

BEGINNING AT A POINT OPPOSITE STATION Rwf 33+67.00, AS SHOWN ON CITY OF SUMNER "FRYAR AVENUE SHARED USE TRAIL RIGHT OF WAY PLANS" ON FILE WITH THE CITY, 37.00 FEET WESTERLY THEREFROM;

THENCE SOUTHERLY IN A STRAIGHT LINE TO A POINT OPPOSITE STATION 33+42.50, 37.00 FEET WESTERLY THEREFROM;

THENCE SOUTHWESTERLY IN A STRAIGHT LINE TO A POINT OPPOSITE STATION 33+39.32, 39.00 FEET WESTERLY THEREFROM;

THENCE NORTHERLY IN A STRAIGHT LINE TO A POINT OPPOSITE STATION 33+67.00, 39.00 FEET WESTERLY THEREFROM;

THENCE WESTERLY TO THE POINT OF BEGINNING.

CONTAINING 52 SQUARE FEET, MORE OR LESS.

TOGETHER WITH:

BEGINNING AT A POINT OPPOSITE STATION Rwf 32+26.98, AS SHOWN ON SAID CITY OF SUMNER "FRYAR AVENUE SHARED USE TRAIL RIGHT OF WAY PLANS" ON FILE WITH THE CITY, 39.00 FEET WESTERLY THEREFROM;

THENCE SOUTHEASTERLY IN A STRAIGHT LINE TO A POINT OPPOSITE STATION 32+23.75, 37.00 FEET WESTERLY THEREFROM;

THENCE SOUTHERLY IN A STRAIGHT LINE TO A POINT OPPOSITE STATION 30+27.00, 37.00 FEET WESTERLY THEREFROM;

THENCE WESTERLY IN A STRAIGHT LINE TO A POINT OPPOSITE STATION 30+27.00, 39.00 FEET WESTERLY THEREFROM;

THENCE NORTHERLY TO THE POINT OF BEGINNING.

CONTAINING 397 SQUARE FEET, MORE OR LESS.

TOGETHER WITH:

BEGINNING AT A POINT OPPOSITE STATION Rwf 30+00.00, AS SHOWN ON SAID CITY OF SUMNER "FRYAR AVENUE SHARED USE TRAIL RIGHT OF WAY PLANS" ON FILE WITH THE CITY, 37.00 FEET WESTERLY THEREFROM;

THENCE SOUTHERLY IN A STRAIGHT LINE TO A POINT OPPOSITE STATION 29+79.48, 37.00 FEET WESTERLY THEREFROM;

THENCE WESTERLY IN A STRAIGHT LINE TO A POINT OPPOSITE STATION 29+79.48, 39.00 FEET WESTERLY THEREFROM;

22-SLOPE.DOCX

THENCE NORTHERLY IN A STRAIGHT LINE TO A POINT OPPOSITE STATION 30+00.00, 39.00 FEET WESTERLY THEREFROM;

THENCE EASTERLY TO THE POINT OF BEGINNING.

CONTAINING 41 SQUARE FEET, MORE OR LESS.

TOTAL SLOPE EASEMENT CONTAINING 490 SQUARE FEET, MORE OR LESS.

**TRACT:**

(PER CHICAGO TITLE COMPANY ORDER NO. 242507, DATED JULY 19, 2024)

BEGINNING ON THE SOUTH LINE OF THE CHICAGO, MILWAUKEE, ST. PAUL RAILROAD RIGHT OF WAY, AT THE INTERSECTION OF THE WEST LINE OF THE WILLIAMS COUNTY ROAD;  
THENCE SOUTH ON THE WEST LINE OF SAID ROAD 434 FEET;  
THENCE WEST AT RIGHT ANGLES TO WILLIAMS STREET TO THE CENTER LINE OF THE STUCK RIVER;  
THENCE NORTHERLY ALONG SAID CENTER LINE TO THE SOUTHERLY LINE OF THE CHICAGO, MILWAUKEE, ST. PAUL RAILWAY COMPANY SPUR RIGHT OF WAY;  
THENCE EAST ALONG SAID RIGHT OF WAY TO THE POINT OF BEGINNING;  
EXCEPT THAT PORTION THEREOF WITHIN THE BED OF THE STUCK RIVER;  
BEING A PORTION OF THE A. MORRISON DONATION LAND CLAIM IN SECTION 24, TOWNSHIP 20 NORTH, RANGE 4 EAST OF THE WILLAMETTE MERIDIAN, IN PIERCE COUNTY, WASHINGTON.

09/24/24



NW 1/4, SEC. 24, T. 20 N., R. 4 E., W.M.

CHICAGO, MILWAUKEE & ST. PAUL RR

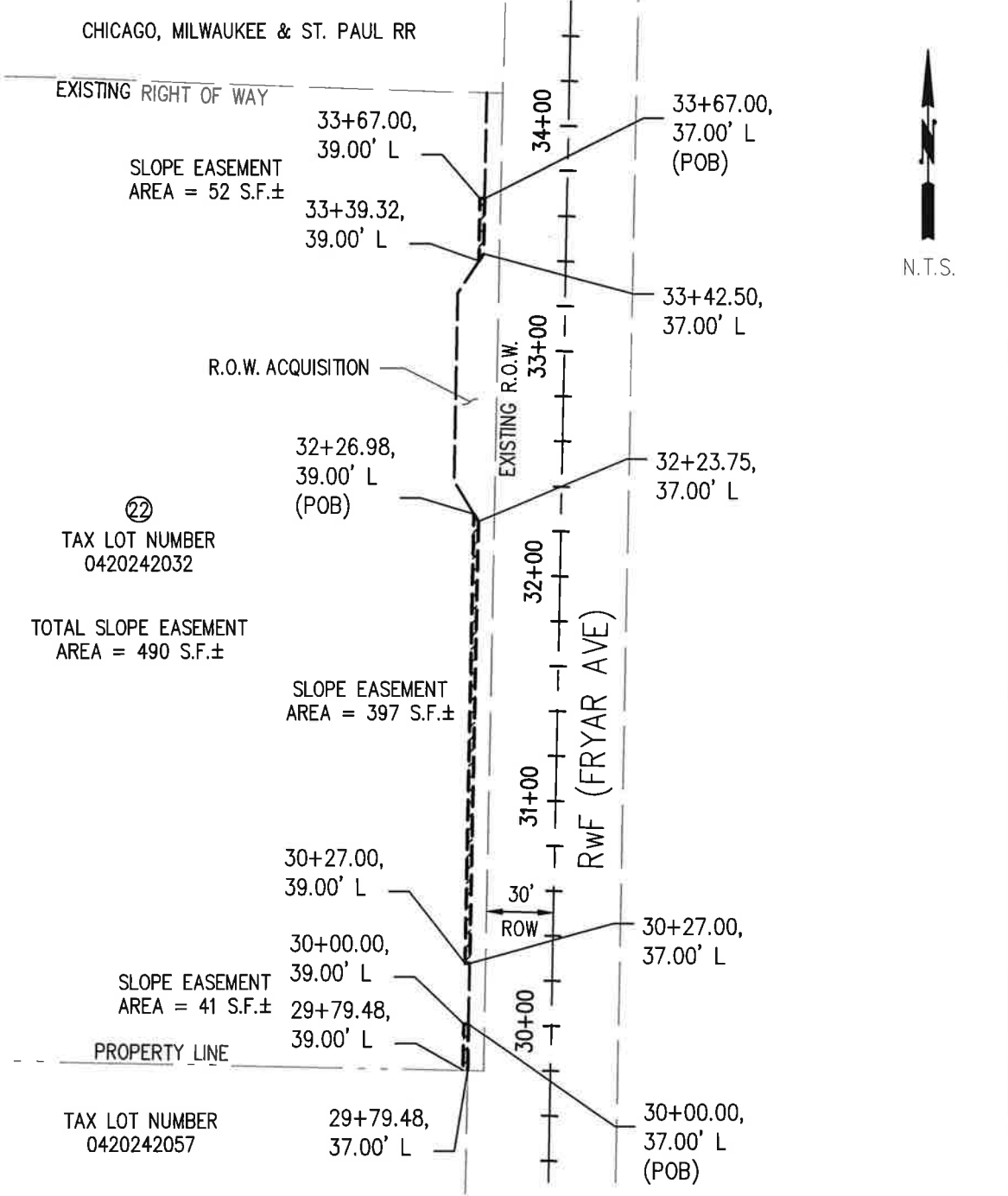

SLOPE EASEMENT  
AREA = 52 S.F.±

R.O.W. ACQUISITION

②  
TAX LOT NUMBER  
0420242032

TOTAL SLOPE EASEMENT  
AREA = 490 S.F.±

SLOPE EASEMENT  
AREA = 397 S.F.±

SLOPE EASEMENT  
AREA = 41 S.F.±

TAX LOT NUMBER  
0420242057

DATE: AUGUST 30, 2024

FILE: 22.DWG



Seattle  
3131 Elliott Avenue, Suite 400  
Seattle, WA 98121 206.296.1640  
Tacoma | Wenatchee | KPG.com

EXHIBIT B  
PARCEL 0420242032  
SLOPE EASEMENT

After recording return document to:

City of Sumner  
1104 Maple Street  
Sumner, WA 98390

**Document Title: Temporary Easement**  
**Grantor: Liberty Property Development Corp.- II**  
**Grantee: City of Sumner**  
**Legal Description: Ptn. NW S-T-R 24-20-4**  
**Additional Legal Description is on Page 5 and 6 of Document.**  
**Assessor's Tax Parcel Number: 0420242057**

## TEMPORARY EASEMENT

### CITY OF SUMNER FRYAR AVENUE SHARED USE TRAIL

The Grantor(s), Liberty Property Development Corp.- II, a Pennsylvania corporation, for and in consideration of TEN AND NO/100 (\$10.00) DOLLARS, and other valuable consideration, conveys and grants unto the City of Sumner, and its assigns, Grantee, under the imminent threat of the Grantee's exercise of its right of Eminent Domain, the right, privilege and non-exclusive easement over, upon, and across the hereinafter described lands for the purpose of ingress, egress, for any and all purposes incidental to constructing, installing, and inspecting slopes, walls, sidewalks, curbs, gutters, drainage and other related road and utility construction activities, including driveway reconnection.

Said lands being situated in Pierce County, State of Washington, and described in Exhibit A and B, attached hereto, and made a part hereof.

The term of this Temporary Easement shall commence on the date of acceptance of this Temporary Easement by Grantee and shall terminate on January 31, 2027, hereinafter the "Term".

Grantee shall provide Grantor written notice no less than 30 days in advance of Grantee's intent to exercise its rights under this Temporary Easement.

**TEMPORARY EASEMENT**

It is further agreed that this Temporary Easement may be extended by up to one (1) year at the Grantee’s option. The rate associated with this extension shall be at the same rate as the original Temporary Easement, or at the newly established rate determined by an updated appraisal; whichever is higher. Grantee shall notify Grantor in writing, and render payment, prior to exercising this option.

All project improvements shall be constructed entirely within the public right of way. In the event private improvements in the Easement Area are disturbed or damaged by Grantee’s use of the Easement, on or before the end of the Term, they shall be restored or replaced in as good or better condition as they were immediately before Grantee entered the Easement Area. During the Term, Grantee may on an interim basis, restore the Easement Area to a reasonably safe and convenient condition.

It is understood and agreed that delivery of this temporary easement is hereby tendered and that the terms and obligations hereof shall not become binding upon the City of Sumner unless and until accepted and approved hereon in writing for the City of Sumner, by its authorized agent.

IN WITNESS WHEREOF, said corporation has caused this instrument to be executed by its proper officers this \_\_\_\_\_ day of \_\_\_\_\_, 20\_\_\_\_\_.

Liberty Property Development Corp.- II,  
a Pennsylvania corporation

By:   
Name: Heidi Seal  
Title: Vice President

Accepted and Approved City  
of Sumner

By: \_\_\_\_\_  
Kathy Hayden  
Mayor of the City of Sumner

Date: \_\_\_\_\_

STATE OF Colorado )  
County of Denver )

I certify that I know or have satisfactory evidence that Heidi Seal is the person who appeared before me, and said person acknowledged they signed this instrument, on oath stated that they were authorized to execute the instrument and acknowledged it as the Vice President of Liberty Property Development Corp.-II, a Pennsylvania corporation to be the free and voluntary act of such party for the uses and purposes mentioned in the instrument.

DATED this 13 day of April, 2026.

Tanya M. Young  
(Print Name)

Tanya M. Young  
Notary Public in and for the State of Colorado  
Residing at Avoda CO

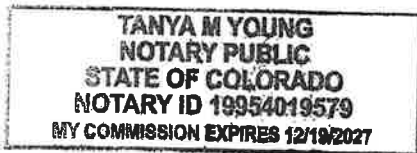

My Appointment Expires: 12/19/2027

**EXHIBIT A**  
**PARCEL NO. 0420242057**  
**TEMPORARY CONSTRUCTION EASEMENT**

THAT PORTION OF THE HEREINAFTER DESCRIBED PARCEL "A", DESCRIBED AS FOLLOWS:

BEGINNING AT STATION Rwf 29+79.48, AS SHOWN ON CITY OF SUMNER "FRYAR AVENUE SHARED USE TRAIL RIGHT OF WAY PLANS" ON FILE WITH THE CITY, 37.00 FEET WESTERLY THEREFROM;

THENCE SOUTHERLY IN A STRAIGHT LINE TO A POINT OPPOSITE STATION 29+71.00, 37.00 FEET WESTERLY THEREFROM;

THENCE WESTERLY IN A STRAIGHT LINE TO A POINT OPPOSITE STATION 29+71.00, 46.00 FEET WESTERLY THEREFROM;

THENCE NORTHERLY IN A STRAIGHT LINE TO A POINT OPPOSITE STATION 29+79.47, 46.00 FEET WESTERLY THEREFROM;

THENCE EASTERLY TO THE POINT OF BEGINNING.

CONTAINING 76 SQUARE FEET, MORE OR LESS.

TOGETHER WITH:

BEGINNING AT STATION Rwf 29+57.00, 37.00 FEET WESTERLY THEREFROM;

THENCE SOUTHERLY IN A STRAIGHT LINE TO A POINT OPPOSITE STATION 29+41.00, 37.00 FEET WESTERLY THEREFROM;

THENCE WESTERLY IN A STRAIGHT LINE TO A POINT OPPOSITE STATION 29+41.00, 42.00 FEET WESTERLY THEREFROM;

THENCE NORTHERLY IN A STRAIGHT LINE TO A POINT OPPOSITE STATION 29+57.00, 42.00 FEET WESTERLY THEREFROM;

THENCE EASTERLY TO THE POINT OF BEGINNING.

CONTAINING 80 SQUARE FEET, MORE OR LESS.

TOTAL TEMPORARY CONSTRUCTION EASEMENT CONTAINING 156 SQUARE FEET, MORE OR LESS.

PARCEL "A":

(PER CHICAGO TITLE COMPANY ORDER NO. 242507, DATED JULY 19, 2024)

PARCEL A:

THE NORTH 203 FEET OF THE COMBINED AREAS OF TRACTS A AND B, EXCEPT THE EASTERLY 7 FEET THEREOF CONVEYED TO THE CITY OF SUMNER BY QUIT CLAIM DEED RECORDED UNDER RECORDING NUMBER 8904210092.

TRACT A:

A PORTION OF THE NORTHWEST QUARTER OF SECTION 24, TOWNSHIP 20 NORTH, RANGE 4 EAST, WILLAMETTE MERIDIAN, IN PIERCE COUNTY, WASHINGTON, DESCRIBED AS FOLLOWS:  
BEGINNING AT A POINT ON THE SOUTH LINE OF THE A. MORRISON DONATION LAND CLAIM AT ITS INTERSECTION WITH THE WEST LINE OF FRYAR AVENUE;

21-TCE.DOCX

THENCE NORTH 19°42' EAST 250 FEET, MORE OR LESS, TO THE INTERSECTION OF SAID WEST LINE OF FRYAR AVENUE WITH THE EXTENSION OF THE CENTER LINE OF ZEHNDER STREET;  
THENCE NORTH 00°49' WEST 143 FEET, MORE OR LESS, TO THE CENTER LINE OF MCMILLIN CREEK;  
THENCE SOUTHWESTERLY ALONG SAID CENTER LINE OF SAID CREEK, 475 FEET, MORE OR LESS, TO ITS INTERSECTION WITH THE CENTER LINE OF THE STUCK RIVER;  
THENCE SOUTHWESTERLY ALONG THE CENTER LINE OF SAID STUCK RIVER TO THE SOUTH LINE OF THE A. MORRISON DONATION LAND CLAIM;  
THENCE NORTH 88°47' EAST 300 FEET, MORE OR LOSS, TO THE POINT OF BEGINNING.

TRACT B:  
COMMENCING AT THE INTERSECTION OF THE CENTER LINE OF ZEHNDER STREET AND THE CENTER LINE OF NEUBERG ROAD IN THE WEST HALF OF A. MORRISON DONATION LAND CLAIM IN SECTION 24, TOWNSHIP 20 NORTH, RANGE 4 EAST, WILLAMETTE MERIDIAN, IN PIERCE COUNTY, WASHINGTON, BEING A POINT 1333.41 FEET WEST AND 233.45 FEET NORTH OF THE INTERSECTION OF THE EAST LINE OF SAID WEST HALF OF SAID DONATION LAND CLAIM AND THE SOUTH LINE OF SAID DONATION LAND CLAIM;  
THENCE SOUTH 87°15' WEST 30 FEET ALONG THE CENTER LINE OF ZEHNDER STREET TO THE WEST LINE OF SAID NEUBERG ROAD;  
THENCE ALONG SAID WEST LINE OF NEUBERG ROAD, NORTH 00°04' WEST 143 FEET TO THE CENTER LINE OF MCMILLIN CREEK AND THE TRUE POINT OF BEGINNING;  
THENCE CONTINUING NORTH 00°49' WEST TO THE NORTHERLY BOUNDARY OF CHICAGO, MILWAUKEE, ST. PAUL AND PACIFIC RAILWAY COMPANY SPUR RIGHT OF WAY CONVEYED IN INSTRUMENT RECORDED UNDER RECORDING NUMBER 370977;  
THENCE WESTERLY ALONG THE NORTH LINE OF SAID SPUR TO THE CENTER OF STUCK RIVER;  
THENCE IN A SOUTHERLY DIRECTION ALONG THE CENTER OF SAID RIVER TO THE CENTER LINE OF MCMILLIN CREEK;  
THENCE NORTH 49°48' EAST 278 FEET;  
THENCE NORTH 59°02' EAST 48.7 FEET;  
THENCE SOUTH 66°15' EAST 52.8 FEET TO THE TRUE POINT OF BEGINNING;

EXCEPT THE FOLLOWING DESCRIBED PROPERTY:  
BEGINNING ON THE NORTH LINE OF CHICAGO, MILWAUKEE, ST. PAUL AND PACIFIC RAILWAY COMPANY SPUR RIGHT OF WAY, AT THE INTERSECTION OF THE WEST LINE OF WILLIAMS COUNTY ROAD, ALSO KNOWN AS NEUBERG ROAD;  
THENCE SOUTH ON THE WEST LINE OF WILLIAMS COUNTY ROAD, 494 FEET;  
THENCE WEST AT RIGHT ANGLES TO SAID WILLIAMS ROAD TO THE CENTER LINE OF STUCK RIVER;  
THENCE NORTHERLY ALONG SAID CENTER LINE TO THE NORTHERLY LINE OF CHICAGO, MILWAUKEE, ST. PAUL PACIFIC AND RAILWAY COMPANY SPUR RIGHT OF WAY;  
THENCE EAST ALONG SAID SPUR RIGHT OF WAY TO THE POINT OF BEGINNING;

ALSO EXCEPT ANY PORTION THEREOF WITHIN BED OF STUCK RIVER.

04/04/2025



NW 1/4, SEC. 24, T. 20 N., R. 4 E., W.M.

TAX LOT NUMBER  
0420242032

29+79.48,  
37.00' L

29+79.47,  
46.00' L

PROPERTY LINE

TEMPORARY CONSTRUCTION EASEMENT  
AREA = 76 S.F.±

29+71.00,  
46.00' L

POB

29+71.00,  
37.00' L

30'  
ROW

30+00



N.T.S.

RwF (FRYAR AVE)

TOTAL TEMPORARY CONSTRUCTION  
EASEMENT AREA = 156 S.F.±

29+57.00,  
42.00' L

POB

29+57.00,  
37.00' L

②

TAX LOT NUMBER  
0420242057

29+41.00,  
42.00' L

29+41.00,  
37.00' L

37'  
ROW

29+00

EXISTING RIGHT OF WAY

TEMPORARY CONSTRUCTION EASEMENT  
AREA = 80 S.F.±

DATE: APRIL 2, 2025

FILE: 21.DWG



Seattle  
3131 Elliott Avenue, Suite 400  
Seattle, WA 98121 206.286.1640  
Tacoma | Wenatchee | KPG.com

EXHIBIT B  
PARCEL 0420242057  
TEMPORARY CONSTRUCTION EASEMENT

After recording return document to:

City of Sumner  
1104 Maple Street  
Sumner, WA 98390

**Document Title: Temporary Easement**  
**Grantor: Liberty Property Development Corp.- II**  
**Grantee: City of Sumner**  
**Legal Description: Ptn. NW S-T-R 24-20-4**  
**Additional Legal Description is on Page 5 and 6 of Document.**  
**Assessor's Tax Parcel Number: 0420242032**

## **TEMPORARY EASEMENT**

### **CITY OF SUMNER FRYAR AVENUE SHARED USE TRAIL**

The Grantor(s), Liberty Property Development Corp.- II, a Pennsylvania corporation, for and in consideration of TEN AND NO/100 (\$10.00) DOLLARS, and other valuable consideration, conveys and grants unto the City of Sumner, and its assigns, Grantee, under the imminent threat of the Grantee's exercise of its right of Eminent Domain, the right, privilege and non-exclusive easement over, upon, and across the hereinafter described lands for the purpose of ingress, egress, for any and all purposes incidental to constructing, installing, and inspecting slopes, walls, sidewalks, curbs, gutters, drainage and other related road and utility construction activities, including driveway reconnection.

Said lands being situated in Pierce County, State of Washington, and described in Exhibit A and B, attached hereto, and made a part hereof.

The term of this Temporary Easement shall commence on the date of acceptance of this Temporary Easement by Grantee and shall terminate on January 31, 2027, hereinafter the "Term".

Grantee shall provide Grantor written notice no less than 30 days in advance of Grantee's intent to exercise its rights under this Temporary Easement.

**TEMPORARY EASEMENT**

It is further agreed that this Temporary Easement may be extended by up to one (1) year at the Grantee's option. The rate associated with this extension shall be at the same rate as the original Temporary Easement, or at the newly established rate determined by an updated appraisal; whichever is higher. Grantee shall notify Grantor in writing, and render payment, prior to exercising this option.

All project improvements shall be constructed entirely within the public right of way. In the event private improvements in the Easement Area are disturbed or damaged by Grantee's use of the Easement, on or before the end of the Term, they shall be restored or replaced in as good or better condition as they were immediately before Grantee entered the Easement Area. During the Term, Grantee may on an interim basis, restore the Easement Area to a reasonably safe and convenient condition.

It is understood and agreed that delivery of this temporary easement is hereby tendered and that the terms and obligations hereof shall not become binding upon the City of Sumner unless and until accepted and approved hereon in writing for the City of Sumner, by its authorized agent.

IN WITNESS WHEREOF, said corporation has caused this instrument to be executed by its proper officers this \_\_\_\_\_ day of \_\_\_\_\_, 20\_\_\_\_\_.

Liberty Property Development Corp.- II,  
a Pennsylvania corporation

By:   
Name: Heidi Seal  
Title: Vice President

Accepted and Approved City  
of Sumner

By: \_\_\_\_\_  
Kathy Hayden  
Mayor of the City of Sumner

Date: \_\_\_\_\_

STATE OF Colorado )  
County of Denver }

I certify that I know or have satisfactory evidence that Heidi Seal is the person who appeared before me, and said person acknowledged they signed this instrument, on oath stated that they were authorized to execute the instrument and acknowledged it as the Vice President of Liberty Property Development Corp.-II, a Pennsylvania corporation to be the free and voluntary act of such party for the uses and purposes mentioned in the instrument.

DATED this 13 day of April, 2026.

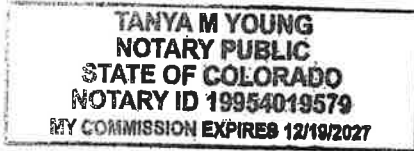

Tanya M. Young  
(Print Name)  
Tanya M Young  
Notary Public in and for the State of Colorado  
Residing at Aurora CO

My Appointment Expires: 12/19/2027

**EXHIBIT A**  
**PARCEL NO. 0420242032**  
**TEMPORARY CONSTRUCTION EASEMENT**

THAT PORTION OF THE HEREINAFTER DESCRIBED TRACT DESCRIBED AS FOLLOWS:

BEGINNING AT A POINT OPPOSITE STATION Rwf 32+71.90, AS SHOWN ON CITY OF SUMNER "FRYAR AVENUE SHARED USE TRAIL RIGHT OF WAY PLANS" ON FILE WITH THE CITY, 48.00 FEET WESTERLY THEREFROM;

THENCE SOUTHERLY IN A STRAIGHT LINE TO A POINT OPPOSITE STATION 32+57.40, 48.00 FEET WESTERLY THEREFROM;

THENCE WESTERLY IN A STRAIGHT LINE TO A POINT OPPOSITE STATION 32+57.40, 58.00 FEET WESTERLY THEREFROM;

THENCE NORTHERLY IN A STRAIGHT LINE TO A POINT OPPOSITE STATION 32+71.90, 58.00 FEET WESTERLY THEREFROM;

THENCE EASTERLY TO THE POINT OF BEGINNING.

CONTAINING 145 SQUARE FEET, MORE OR LESS.

TOGETHER WITH:

BEGINNING AT A POINT OPPOSITE STATION Rwf 30+27.00, AS SHOWN ON CITY OF SUMNER "FRYAR AVENUE SHARED USE TRAIL RIGHT OF WAY PLANS" ON FILE WITH THE CITY, 37.00 FEET WESTERLY THEREFROM;

THENCE SOUTHERLY IN A STRAIGHT LINE TO A POINT OPPOSITE STATION 30+00.00, 37.00 FEET WESTERLY THEREFROM;

THENCE WESTERLY IN A STRAIGHT LINE TO A POINT OPPOSITE STATION 30+00.00, 42.00 FEET WESTERLY THEREFROM;

THENCE NORTHERLY IN A STRAIGHT LINE TO A POINT OPPOSITE STATION 30+27.00, 42.00 FEET WESTERLY THEREFROM;

THENCE EASTERLY TO THE POINT OF BEGINNING.

CONTAINING 135 SQUARE FEET, MORE OR LESS.

TOGETHER WITH:

BEGINNING AT A POINT OPPOSITE STATION Rwf 29+79.48, AS SHOWN ON SAID CITY OF SUMNER "FRYAR AVENUE SHARED USE TRAIL RIGHT OF WAY PLANS" ON FILE WITH THE CITY, 39.00 FEET WESTERLY THEREFROM;

THENCE WESTERLY IN A STRAIGHT LINE TO A POINT OPPOSITE STATION 29+79.47, 46.00 FEET WESTERLY THEREFROM;

THENCE NORTHERLY IN A STRAIGHT LINE TO A POINT OPPOSITE STATION 29+91.00, 46.00 FEET WESTERLY THEREFROM;

THENCE EASTERLY IN A STRAIGHT LINE TO A POINT OPPOSITE STATION 29+91.00, 39.00 FEET WESTERLY THEREFROM;

22-TCE.DOCX

THENCE SOUTHERLY TO THE POINT OF BEGINNING.

CONTAINING 81 SQUARE FEET, MORE OR LESS.

TOTAL TEMPORARY CONSTRUCTION EASEMENT CONTAINING 361 SQUARE FEET, MORE OR LESS.

TRACT:

(PER CHICAGO TITLE COMPANY ORDER NO. 242507, DATED JULY 19, 2024)

BEGINNING ON THE SOUTH LINE OF THE CHICAGO, MILWAUKEE, ST. PAUL RAILROAD RIGHT OF WAY, AT THE INTERSECTION OF THE WEST LINE OF THE WILLIAMS COUNTY ROAD;  
THENCE SOUTH ON THE WEST LINE OF SAID ROAD 434 FEET;  
THENCE WEST AT RIGHT ANGLES TO WILLIAMS STREET TO THE CENTER LINE OF THE STUCK RIVER;  
THENCE NORTHERLY ALONG SAID CENTER LINE TO THE SOUTHERLY LINE OF THE CHICAGO, MILWAUKEE, ST. PAUL RAILWAY COMPANY SPUR RIGHT OF WAY;  
THENCE EAST ALONG SAID RIGHT OF WAY TO THE POINT OF BEGINNING;  
EXCEPT THAT PORTION THEREOF WITHIN THE BED OF THE STUCK RIVER;  
BEING A PORTION OF THE A. MORRISON DONATION LAND CLAIM IN SECTION 24, TOWNSHIP 20 NORTH, RANGE 4 EAST OF THE WILLAMETTE MERIDIAN, IN PIERCE COUNTY, WASHINGTON.

04/04/2025



NW 1/4, SEC. 24, T. 20 N., R. 4 E., W.M.

CHICAGO, MILWAUKEE & ST. PAUL RR

EXISTING RIGHT OF WAY



N.T.S.

32+71.90,  
48.00' L (POB)  
32+71.90,  
58.00' L  
TEMPORARY CONSTRUCTION EASEMENT  
AREA = 145 S.F.±

②  
TAX LOT NUMBER  
0420242032

R.O.W. ACQUISITION

TOTAL TEMPORARY CONSTRUCTION  
EASEMENT AREA = 361 S.F.±

30+27.00,  
37.00' L (POB)  
30+27.00,  
42.00' L  
30+00.00,  
42.00' L  
TEMPORARY CONSTRUCTION EASEMENT  
AREA = 135 S.F.±

29+91.00,  
46.00' L  
TEMPORARY CONSTRUCTION EASEMENT  
AREA = 81 S.F.±

PROPERTY LINE

TAX LOT NUMBER  
0420242057

29+79.47,  
46.00' L  
29+79.48,  
39.00' L (POB)

EXISTING R.O.W.

34+00  
33+00  
32+00  
31+00  
30+00

RWF (FRYAR AVE)

30'  
ROW

30+00.00,  
37.00' L

29+91.00,  
39.00' L

DATE: APRIL 2, 2025

FILE: 22.DWG



Seattle  
3131 Elliott Avenue, Suite 400  
Seattle, WA 98121 206.286.1640  
Tacoma | Wenatchee | KPG.com

EXHIBIT B  
PARCEL 0420242032  
TEMPORARY CONSTRUCTION EASEMENT

---

**SUBJECT:** Fryar Ave Trail Project Property Acquisition - Lewis Landmark, LLC

**CATEGORY:** Consent

---

**BUDGET IMPACT:**

Expenditure Required: \$42,785.00

Within Budget Allocation: Yes

---

**ATTACHMENTS:**

1. Property Acquisition Documents - Lewis Landmark

**STAFF CONTACT:** Andrew Leach, Senior Associate City Engineer

---

**SUMMARY BACKGROUND:**

The Fryar Trail Project will construct approximately 3,300 linear feet of shared use path that parallels Fryar Avenue from West Main Street to Puyallup Street. In order to construct the project, partial acquisitions and/or easements are needed from twenty-three parcels along the project corridor. These twenty-three parcels are owned by thirteen different property owners. The City of Sumner was awarded \$655,143 in Federal CMAQ funding for right of way purchases and \$5,000,000 in WSDOT Pedestrian & Bicycle Safety Program state funds for completing the design, right of way, and construction of the project.

As part of the anticipated Fryar Avenue Trail project, the City is currently in the property acquisition phase. The Lewis Landmark, LLC is a property owner within the project footprint. Lewis Landmark is willingly conveying the necessary property to the City for the project, for an agreed-upon price of \$42,785.00. This project is grant funded and this acquisition was negotiated with the assistance of the City's consultant, Commonstreet in accordance with all applicable laws.

---

**COUNCIL COMMITTEE/STUDY SESSION:** Public Works Committee



**MEETING/STUDY SESSION DATE:** 4/21/2026

**COMMITTEE RECOMMENDATION:** Do Pass

**STAFF RECOMMENDATIONS/MOTION:**

Motion authorizing the negotiated purchase of property from The Lewis Landmark, LLC for purposes of constructing the Fryar Avenue Trail project for \$42,785.00 and authorizing Mayor to execute any and all documents necessary to effectuate the purchase in a form as approved by the City Attorney.

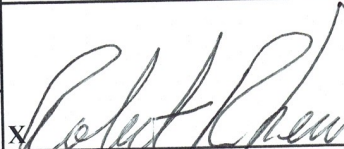
## REAL PROPERTY VOUCHER

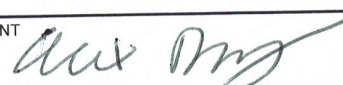
AGENCY NAME  <p style="text-align: center;"><b>City of Sumner</b> 1104 Maple Street Sumner, WA 98390</p>		I hereby certify under penalty of perjury that the items and amounts listed herein are proper charges against the Agency, that the same or any part thereof has not been paid, and that I am authorized to sign for the claimant.		
GRANTOR OR CLAIMANT (NAME, ADDRESS) <b>The Lewis Landmark, LLC</b> 1710 Fryar Avenue Suite 105 Sumner, WA 98390		TIN/SSN: <input checked="" type="checkbox"/>	SIGNATURE (IN INK) FOR EACH CLAIMANT  X  <b>Robert R. Lewis, Manager</b>	DATED  4/8/26 4/8/26
		PROJECT NO. AND TITLE <b>Fryar Avenue Shared Use Trail</b> <b>A15.0029</b>		
		FEDERAL AID NO. <b>TAP 1270(012)</b>	PARCEL NO. <b>0420242063</b>	X  <b>Shirley Lea Lewis, Manager</b>
In full, complete and final payment and settlement for the title or interest conveyed or released, as fully set forth in:		DATED	\$ AMOUNT	
Warranty deed, temporary easement				\$33,900.00
LAND: Fee Acquisition: 1,127 SF			+	\$4,300.00
Temporary Easement: 882 SF				
IMPROVEMENTS: Large shrubs and mature arborvitae			+	\$1,000.00
DAMAGES: Cost to Cure			+	
Proximity			+	
Other			+	
SPECIAL BENEFITS				
JC (Just Compensation) Amount				\$39,200.00
REMAINDER: Uneconomic Remnant			+	
Excess Acquisition			+	
ADMINISTRATIVE SETTLEMENT			+	\$3,000.00
STATUTORY EVALUATION ALLOWANCE			+	\$585.00
ESCROW FEE			+	
REAL ESTATE EXCISE TAX			+	
OTHER:			+	
ACQUISITION AGENT 		DATE 4/13/26	Voucher No.	TOTAL AMOUNT PAID \$42,785.00
AUTHORIZED AGENT FOR AGENCY		DATE		

After recording return document to:

City of Sumner  
1104 Maple Street  
Sumner, WA 98390

**Document Title: Warranty Deed**  
**Grantor: The Lewis Landmark, LLC**  
**Grantee: City of Sumner**  
**Legal Description: Ptn. NW 1/4 Section 24-20N-4E**  
**Additional Legal Description is on Pages 4 and 5 of Document**  
**Assessor's Tax Parcel Number: Ptn. 0420242063**

## WARRANTY DEED

### CITY OF SUMNER FRYAR AVENUE SHARED USE TRAIL

The Grantor(s), The Lewis Landmark LLC, a Washington limited liability company which acquired title as Lewis Landmark LLC, for and in consideration of the sum of TEN AND NO/100 (\$10.00) Dollars, and other valuable consideration, hereby convey(s) and warrant(s) to the City of Sumner, Grantee, the following described real property situated in Pierce County, in the State of Washington, under the imminent threat of the Grantee's exercise of its rights of Eminent Domain, together with any after acquired interest of the grantor:

For legal description and additional conditions  
See Exhibit A and B attached hereto and made a part hereof.

Also, the undersigned hereby requests the Assessor and Treasurer of said County to set over to the remainder of the herein described Parcel "A" the lien of all unpaid taxes, if any, affecting the property hereby conveyed, as provided by RCW 84.60.070.

**WARRANTY DEED**

It is understood and agreed that delivery of this deed is hereby tendered and that the terms and obligations hereof shall not become binding upon the City of Sumner unless and until accepted and approved hereon in writing for the City of Sumner, by its authorized agent.

Dated: 4/18, 2026

The Lewis Landmark, LLC, a Washington limited liability company

By: Robert R. Lewis  
Robert R. Lewis, Manager

By: Shirley Lea Lewis  
Shirley Lea Lewis, Manager

Accepted and Approved

City of Sumner

By: \_\_\_\_\_  
Kathy Hayden  
Mayor of the City of Sumner

Date: \_\_\_\_\_

**WARRANTY DEED**

**ACKNOWLEDGMENT**

STATE OF Arizona )  
County of Pima )

I certify that I know or have satisfactory evidence that Robert R. Lewis and Shirley Lea Lewis are the persons who appeared before me, and said persons acknowledged they signed this instrument, on oath stated that they were authorized to execute the instrument and acknowledged it as the Managers of The Lewis Landmark LLC, a Washington limited liability company to be the free and voluntary act of such party for the uses and purposes mentioned in the instrument.

DATED this 8<sup>th</sup> day of April, 2026.

Rajinder Kaur  
(Print Name)

Rajinder Kaur  
Notary Public in and for the State of Arizona  
Residing at Pima

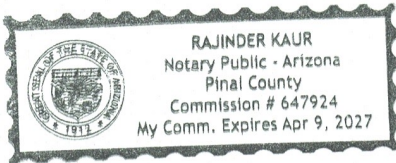

My Appointment Expires:  
04/09/2027

**EXHIBIT A**  
**PARCEL NO. 0420242063**  
**RIGHT OF WAY ACQUISITION**

THAT PORTION OF THE HEREINAFTER DESCRIBED PARCEL "A" LYING EASTERLY OF A LINE THAT IS 35.00 FEET WESTERLY OF AND PARALLEL WITH THE "RwF" LINE AS SHOWN ON CITY OF SUMNER "FRYAR AVENUE SHARED USE TRAIL RIGHT OF WAY PLANS" ON FILE WITH THE CITY, SAID LINE ALSO BEING THE CENTERLINE OF FRYAR AVENUE.

CONTAINING 1,127 SQUARE FEET, MORE OR LESS.

PARCEL "A":  
(PER CHICAGO TITLE COMPANY ORDER NO. 242508, DATED JULY 15, 2024)

COMMENCING AT A MONUMENT AT THE INTERSECTION OF THE WEST LINE OF THE A. MORRISON DONATION LAND CLAIM WITH THE EAST AND WEST CENTER LINE OF THE NORTHWEST QUARTER OF SECTION 24, TOWNSHIP 20 NORTH, RANGE 4 EAST OF THE WILLAMETTE MERIDIAN;  
THENCE EAST, ALONG SAID CENTER LINE, A DISTANCE OF 715 FEET TO A MONUMENT ON THE WEST BOUNDARY LINE OF THAT CERTAIN TRACT OF LAND CONVEYED TO THE FLEISCHMANN COMPANY BY DEED RECORDED UNDER AUDITOR'S FEE NO. 358171;  
THENCE SOUTH ALONG THE WEST BOUNDARY LINE OF SAID FLEISCHMANN TRACT, A DISTANCE OF 109.78 FEET TO A POINT WHICH IS THE INTERSECTION OF SAID WEST BOUNDARY LINE WITH THE NORTH RIGHT-OF-WAY LINE OF THE CHICAGO, MILWAUKEE & ST. PAUL RAILWAY COMPANY'S SPUR TRACK;  
THENCE WEST ALONG SAID NORTH RIGHT-OF-WAY LINE, A DISTANCE OF 240 FEET TO THE TRUE POINT OF BEGINNING;  
THENCE NORTH PARALLEL WITH SAID WEST LINE OF SAID A. MORRISON DONATION LAND CLAIM, A DISTANCE OF 220 FEET;  
THENCE WEST PARALLEL WITH SAID CENTER LINE OF THE NORTHWEST QUARTER OF SAID SECTION 24, A DISTANCE OF 300 FEET;  
THENCE SOUTH PARALLEL WITH SAID WEST LINE OF SAID A. MORRISON DONATION LAND CLAIM, A DISTANCE OF 231.15 FEET TO AN INTERSECTION WITH SAID NORTH RIGHT-OF-WAY LINE;  
THENCE EASTERLY ALONG SAID RIGHT-OF-WAY LINE, A DISTANCE OF 300.71 FEET TO THE POINT OF BEGINNING.

SITUATE IN THE CITY OF SUMNER, COUNTY OF PIERCE, STATE OF WASHINGTON.

09/24/24



NW 1/4, SEC. 24, T. 20 N., R. 4 E., W.M.

TAX LOT NUMBER  
0420242083

PROPERTY LINE

35'  
ROW

37+00

30'  
ROW

RIGHT OF WAY  
AREA = 1127 S.F.±

RwF (FRYAR AVE)



N.T.S.

23

TAX LOT NUMBER  
0420242063

36+00

35.00'

35+00

EXISTING RIGHT OF WAY

CHICAGO, MILWAUKEE & ST. PAUL RR

DATE: AUGUST 30, 2024

FILE: 23.DWG

**KPG**  
PSOMAS

Seattle  
3131 Elliott Avenue, Suite 400  
Seattle, WA 98121 206.286.1640  
Tacoma | Wenatchee | KPG.com

EXHIBIT B  
PARCEL 0420242063  
RIGHT OF WAY ACQUISITION

After recording return document to:

City of Sumner  
1104 Maple Street  
Sumner, WA 98390

**Document Title: Temporary Easement**  
**Grantor: The Lewis Landmark, LLC**  
**Grantee: City of Sumner**  
**Legal Description: Ptn. NW 1/4 Section 24-20N-4E**  
**Additional Legal Description is on Pages 4, 5, and 6 of Document.**  
**Assessor's Tax Parcel Number: Ptn. 0420242063**

## TEMPORARY EASEMENT

### CITY OF SUMNER FRYAR AVENUE SHARED USE TRAIL

The Grantor(s), The Lewis Landmark, LLC, a Washington limited liability company which acquired title as Lewis Landmark LLC, for and in consideration of TEN AND NO/100 (\$10.00) DOLLARS, and other valuable consideration, conveys and grants unto the City of Sumner, and its assigns, Grantee, under the imminent threat of the Grantee's exercise of its right of Eminent Domain, the right, privilege and easement over, upon, and across the hereinafter described lands for the purpose of ingress, egress, for any and all purposes incidental to constructing, installing, and inspecting slopes, walls, sidewalks, curbs, gutters, drainage and other related road and utility construction activities, including driveway reconnection.

Said lands being situated in Pierce County, State of Washington, and described in Exhibit A and B, attached hereto, and made a part hereof.

The term of this Temporary Easement shall commence on the date of acceptance of this Temporary Easement by Grantee and shall terminate on January 31, 2027, hereinafter the "Term".

Grantee shall provide Grantor written notice no less than 14 days in advance of Grantee's intent to exercise its rights under this Temporary Easement.

**TEMPORARY EASEMENT**

It is further agreed that this Temporary Easement may be extended by up to one (1) year at the Grantee's option. The rate associated with this extension shall be at the same rate as the original Temporary Easement, or at the newly established rate determined by an updated appraisal; whichever is higher. Grantee shall notify Grantor in writing, and render payment, prior to exercising this option.

All project improvements shall be constructed entirely within the public right of way. In the event private improvements in the Easement Area are disturbed or damaged by Grantee's use of the Easement, on or before the end of the Term, they shall be restored or replaced in as good or better condition as they were immediately before Grantee entered the Easement Area. During the Term, Grantee may on an interim basis, restore the Easement Area to a reasonably safe and convenient condition.

It is understood and agreed that delivery of this temporary easement is hereby tendered and that the terms and obligations hereof shall not become binding upon the City of Sumner unless and until accepted and approved hereon in writing for the City of Sumner, by its authorized agent.

Dated: 4/8, 2026

The Lewis Landmark, LLC, a Washington limited liability company

By: Robert R. Lewis  
Robert R. Lewis, Manager

By: Shirley Lea Lewis  
Shirley Lea Lewis, Manager

Accepted and Approved

City of Sumner

By: \_\_\_\_\_  
Kathy Hayden  
Mayor of the City of Sumner

Date: \_\_\_\_\_, 2026

**TEMPORARY EASEMENT**

**ACKNOWLEDGMENT**

STATE OF Arizona )  
County of Pima )

I certify that I know or have satisfactory evidence that Robert R. Lewis and Shirley Lea Lewis are the persons who appeared before me, and said persons acknowledged they signed this instrument, on oath stated that they were authorized to execute the instrument and acknowledged it as the Managers of The Lewis Landmark LLC, a Washington limited liability company to be the free and voluntary act of such party for the uses and purposes mentioned in the instrument.

DATED this 8<sup>th</sup> day of April, 2026.

Rajinder Kaur  
(Print Name)

Rajinder Kaur  
Notary Public in and for the State of Arizona  
Residing at Pima County

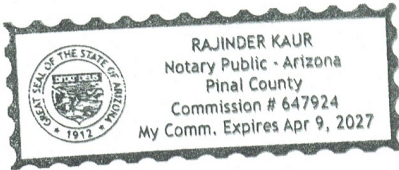

My Appointment Expires:  
04/09/2027

**EXHIBIT A**  
**PARCEL NO. 0420242063**  
**TEMPORARY CONSTRUCTION EASEMENT**

THAT PORTION OF THE HEREINAFTER DESCRIBED TRACT DESCRIBED AS FOLLOWS:

BEGINNING AT A POINT OPPOSITE STATION Rwf 36+99.24, AS SHOWN ON CITY OF SUMNER "FRYAR AVENUE SHARED USE TRAIL RIGHT OF WAY PLANS" ON FILE WITH THE CITY, 35.00 FEET WESTERLY THEREFROM;

THENCE SOUTHERLY IN A STRAIGHT LINE TO A POINT OPPOSITE STATION 36+62.00, 35.00 FEET WESTERLY THEREFROM;

THENCE WESTERLY IN A STRAIGHT LINE TO A POINT OPPOSITE STATION 36+62.00, 45.00 FEET WESTERLY THEREFROM;

THENCE NORTHERLY IN A STRAIGHT LINE TO A POINT OPPOSITE STATION 36+99.24, 45.00 FEET WESTERLY THEREFROM;

THENCE EASTERLY TO THE POINT OF BEGINNING.

CONTAINING 372 SQUARE FEET, MORE OR LESS.

TOGETHER WITH:

BEGINNING AT A POINT OPPOSITE STATION Rwf 34+76.96, AS SHOWN ON SAID CITY OF SUMNER "FRYAR AVENUE SHARED USE TRAIL RIGHT OF WAY PLANS" ON FILE WITH THE CITY, 35.00 FEET WESTERLY THEREFROM;

THENCE WESTERLY IN A STRAIGHT LINE TO A POINT OPPOSITE STATION 34+74.10, 45.00 FEET WESTERLY THEREFROM;

THENCE NORTHERLY IN A STRAIGHT LINE TO A POINT OPPOSITE STATION 35+25.00, 45.00 FEET WESTERLY THEREFROM;

THENCE EASTERLY IN A STRAIGHT LINE TO A POINT OPPOSITE STATION 35+25.00, 35.00 FEET WESTERLY THEREFROM;

THENCE SOUTHERLY TO THE POINT OF BEGINNING.

CONTAINING 510 SQUARE FEET, MORE OR LESS.

TOTAL DRIVEWAY PERMIT AREA CONTAINING 882 SQUARE FEET, MORE OR LESS.

PARCEL "A":  
(PER CHICAGO TITLE COMPANY ORDER NO. 242508, DATED JULY 15, 2024)

COMMENCING AT A MONUMENT AT THE INTERSECTION OF THE WEST LINE OF THE A. MORRISON DONATION LAND CLAIM WITH THE EAST AND WEST CENTER LINE OF THE NORTHWEST QUARTER OF SECTION 24, TOWNSHIP 20 NORTH, RANGE 4 EAST OF THE WILLAMETTE MERIDIAN;

THENCE EAST, ALONG SAID CENTER LINE, A DISTANCE OF 715 FEET TO A MONUMENT ON THE WEST BOUNDARY LINE OF THAT CERTAIN TRACT OF LAND CONVEYED TO THE FLEISCHMANN COMPANY BY DEED RECORDED UNDER AUDITOR'S FEE NO. 358171;

THENCE SOUTH ALONG THE WEST BOUNDARY LINE OF SAID FLEISCHMANN TRACT, A DISTANCE OF 109.78 FEET TO A POINT WHICH IS THE INTERSECTION OF SAID WEST BOUNDARY LINE WITH THE NORTH RIGHT-OF-WAY LINE OF THE CHICAGO, MILWAUKEE & ST. PAUL RAILWAY COMPANY'S SPUR TRACK;

23-TCE.DOCX

THENCE WEST ALONG SAID NORTH RIGHT-OF-WAY LINE, A DISTANCE OF 240 FEET TO THE TRUE POINT OF BEGINNING;  
THENCE NORTH PARALLEL WITH SAID WEST LINE OF SAID A. MORRISON DONATION LAND CLAIM, A DISTANCE OF 220 FEET;  
THENCE WEST PARALLEL WITH SAID CENTER LINE OF THE NORTHWEST QUARTER OF SAID SECTION 24, A DISTANCE OF 300 FEET;  
THENCE SOUTH PARALLEL WITH SAID WEST LINE OF SAID A. MORRISON DONATION LAND CLAIM, A DISTANCE OF 231.15 FEET TO AN INTERSECTION WITH SAID NORTH RIGHT-OF-WAY LINE;  
THENCE EASTERLY ALONG SAID RIGHT-OF-WAY LINE, A DISTANCE OF 300.71 FEET TO THE POINT OF BEGINNING.

SITUATE IN THE CITY OF SUMNER, COUNTY OF PIERCE, STATE OF WASHINGTON.

04/04/2025



NW 1/4, SEC. 24, T. 20 N., R. 4 E., W.M.

TAX LOT NUMBER  
0420242083

36+99.24,  
35.00' L  
(POB)

35'  
ROW

PROPERTY LINE

36+99.24,  
45.00' L

TEMPORARY CONSTRUCTION EASEMENT  
AREA = 372 S.F.±

36+62.00,  
45.00' L

30'  
ROW

36+62.00,  
35.00' L

TOTAL TEMPORARY CONSTRUCTION  
EASEMENT AREA = 882 S.F.±

R.O.W. ACQUISITION

②3

TAX LOT NUMBER  
0420242063

35+25.00,  
35.00' L

RwF (FRYAR AVE)

35.00'

35+25.00,  
45.00' L

TEMPORARY CONSTRUCTION EASEMENT  
AREA = 510 S.F.±

34+74.10,  
45.00' L

EXISTING RIGHT OF WAY

34+73.96,  
35.00' L  
(POB)

CHICAGO, MILWAUKEE & ST. PAUL RR



N.T.S.

DATE: APRIL 2, 2025

FILE: 23.DWG

**KPG**  
**PSOMAS**

Seattle  
3131 Elliott Avenue, Suite 400  
Seattle, WA 98121 206.266.1640  
Tacoma | Wenatchee | KPG.com

EXHIBIT B  
PARCEL 0420242063  
TEMPORARY CONSTRUCTION EASEMENT

---

**SUBJECT:** Fryar Ave Trail Project Property Acquisition - Pierce County

**CATEGORY:** Consent

---

**BUDGET IMPACT:**

Expenditure Required: \$8,200.00

Within Budget Allocation: Yes

---

**ATTACHMENTS:**

1. Property Acquisition Documents - Pierce County

**STAFF CONTACT:** Andrew Leach, Senior Associate City Engineer

---

**SUMMARY BACKGROUND:**

The Fryar Trail Project will construct approximately 3,300 linear feet of shared use path that parallels Fryar Avenue from West Main Street to Puyallup Street. In order to construct the project, partial acquisitions and/or easements are needed from twenty-three parcels along the project corridor. These twenty-three parcels are owned by thirteen different property owners. The City of Sumner was awarded \$655,143 in Federal CMAQ funding for right of way purchases and \$5,000,000 in WSDOT Pedestrian & Bicycle Safety Program state funds for completing the design, right of way, and construction of the project.

As part of the anticipated Fryar Avenue Trail project, the City is currently in the property acquisition phase. Pierce County is a property owner within the project footprint. Pierce County is willingly conveying the necessary property to the City for the project, for an agreed-upon price of \$8,200.00. This project is grant funded and this acquisition was negotiated with the assistance of the City's consultant, Commonstreet in accordance with all applicable laws.

---

<p><b>COUNCIL COMMITTEE/STUDY SESSION:</b> Public Works Committee <b>MEETING/STUDY SESSION DATE:</b> 4/21/2026 <b>COMMITTEE RECOMMENDATION:</b> Do Pass</p>
---

**STAFF RECOMMENDATIONS/MOTION:**

Motion authorizing the negotiated purchase of property from Pierce County for purposes of constructing the Fryar Avenue Trail project for \$8,200.00 and authorizing Mayor to execute any and all documents necessary to effectuate the purchase in a form as approved by the City Attorney.

# REAL PROPERTY VOUCHER

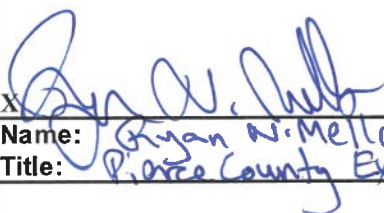
<b>AGENCY NAME</b>  <p style="text-align: center;"><b>City of Sumner</b> 1104 Maple Street Sumner, WA 98390</p>		I hereby certify under penalty of perjury that the items and amounts listed herein are proper charges against the Agency, that the same or any part thereof has not been paid, and that I am authorized to sign for the claimant.		
<b>GRANTOR OR CLAIMANT (NAME, ADDRESS)</b> Pierce County 2702 South 42nd Street, Suite 109 Tacoma, WA 98409		<b>TIN/SSN:</b> _____	<b>SIGNATURE (IN INK) FOR EACH CLAIMANT</b>  	<b>DATED</b>  _____
<b>PROJECT NO. AND TITLE</b> Fryar Avenue Shared Use Trail A15.0029		<b>Name:</b> Bryan W. Mello <b>Title:</b> Pierce County Executive		
<b>FEDERAL AID NO.</b> TAP 1270(012)	<b>PARCEL NO.</b> 0420243011	<b>Name:</b> _____	<b>Title:</b> _____	
In full, complete and final payment and settlement for the title or interest conveyed or released, as fully set forth in: Quitclaim Deed, Temporary Easement		<b>DATED</b> _____	<b>\$ AMOUNT</b>	
<b>LAND:</b> Fee acquisition: 2,164 SF Temporary Easement: 1,223 SF		+ +	\$7,100.00 \$1,100.00	
<b>IMPROVEMENTS:</b>		+		
<b>DAMAGES:</b> Cost to Cure Proximity Other		+ + +		
<b>SPECIAL BENEFITS</b>				
<b>JC (Just Compensation) Amount</b>			\$8,200.00	
<b>REMAINDER:</b> Uneconomic Remnant Excess Acquisition		+ +		
<b>ADMINISTRATIVE SETTLEMENT</b>		+		
<b>STATUTORY EVALUATION ALLOWANCE</b>		+		
<b>ESCROW FEE</b>		+		
<b>REAL ESTATE EXCISE TAX</b>		+		
<b>OTHER:</b>		+		
<b>ACQUISITION AGENT</b> _____	<b>DATE</b> _____	<b>Voucher No.</b> _____	<b>TOTAL AMOUNT PAID</b>  \$8,200.00	
<b>AUTHORIZED AGENT FOR AGENCY</b> _____	<b>DATE</b> _____			

After recording return document to:

City of Sumner  
1104 Maple Street  
Sumner, WA 98390

**Document Title: Quitclaim Deed**  
**Reference Number of Related Document: N/A**  
**Grantor: Pierce County**  
**Grantee: City of Sumner**  
**Legal Description: Ptn. NE 1/4 of SW 1/4 of S24, T20N, R04E.W.M.**  
**Additional Legal Description is on Page 4 and 5 of Document**  
**Assessor's Tax Parcel Number: 0420243011**

## QUITCLAIM DEED

### CITY OF SUMNER FRYAR AVENUE SHARED USE TRAIL

The Grantor, Pierce County, a Washington municipal corporation and a legal subdivision of the State of Washington, who acquired title as Pierce County, a political subdivision of the State of Washington, for and in consideration of the sum of TEN AND NO/100 (\$10.00) Dollars, and other valuable consideration, conveys and quitclaims to the City of Sumner, Grantee, the following described real property, and any after-acquired interest therein, situated in Pierce County, in the State of Washington:

For legal description and additional conditions

See Exhibits A (legal description) and B (depiction) attached hereto and made a part hereof.

Provided, however, that Grantor reserves and retains an easement, with a right of continuing access with no less than 24 hours' notice except in the case of an emergency, over, under, upon, across, through, and burdening the real property described in Exhibit A and depicted in Exhibit B, for the limited purposes of river control, surface water control, and flood risk reduction purposes, specifically including (without limitation) the right to use the described real property to construct, excavate, operate, maintain, repair, and improve river control facilities, surface water control facilities, and flood risk reduction infrastructure.

**QUITCLAIM DEED**

It is understood and agreed that delivery of this deed is hereby tendered and that the terms and obligations hereof shall not become binding upon the City of Sumner unless and until accepted and approved hereon in writing for the City of Sumner, by its authorized agent.

Dated: April 8, 2026

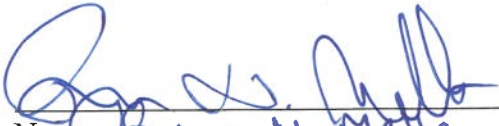
  
Name: Bryan N. Melto  
Title: Pierce County Executive

\_\_\_\_\_  
Name:  
Title:

Accepted and Approved  
City of Sumner

By: \_\_\_\_\_  
Carla S. Bowman  
Mayor of the City of Sumner

Date: \_\_\_\_\_

**QUITCLAIM DEED**

**ACKNOWLEDGMENT**

STATE OF WASHINGTON )

County of Pierce )

On this 8 day of April, 2020, before me, the undersigned, a Notary Public in and for the State of Washington, duly commissioned and sworn, personally appeared Ryan N. Mello, to me known to be the Executive, respectively of PIERCE COUNTY, the corporation that executed the foregoing instrument, and acknowledged the said instrument to be the free and voluntary act and deed of said corporation, for the uses and purposes therein mentioned, and on oath stated that he/she is authorized to execute the said instrument and that the seal affixed (if any) is the corporate seal of said corporation.

WITNESS my hand and official seal hereto affixed the day and year first written above.



Lisa Carasella  
(Print Name)

Lisa Carasella  
Notary Public in and for the State of Washington  
Residing at Tacoma, WA

My Appointment Expires:  
12/15/2029

APPROVED as to form only:

DPA Northrip approved as to form by 3/19/2026 email  
Pierce County Deputy Prosecuting Attorney

**EXHIBIT A**  
**PARCEL NO. 0420243011**  
**RIGHT OF WAY ACQUISITION**

THAT PORTION OF THE HEREINAFTER DESCRIBED PARCEL "A", LYING EASTERLY OF THE FOLLOWING DESCRIBED LINE:

BEGINNING AT A POINT OPPOSITE STATION Rwl 16+58.80, AS SHOWN ON SAID CITY OF SUMNER "FRYAR AVENUE SHARED USE TRAIL RIGHT OF WAY PLANS" ON FILE WITH THE CITY, 16.56 FEET WESTERLY THEREFROM;

THENCE SOUTHERLY IN A STRAIGHT LINE TO A POINT OPPOSITE STATION 15+90.00, 17.79 FEET WESTERLY THEREFROM;

THENCE SOUTHERLY IN A STRAIGHT LINE TO A POINT OPPOSITE STATION 14+75.34, 16.00 FEET WESTERLY THEREFROM;

THENCE SOUTHERLY IN A STRAIGHT LINE TO A POINT OPPOSITE STATION 14+23.13, 5.02 FEET EASTERLY AND THE TERMINUS OF SAID DESCRIBED LINE.

CONTAINING 2,164 SQUARE FEET, MORE OR LESS.

PARCEL "A":

(PER CHICAGO TITLE COMPANY ORDER NO. 242503, DATED JULY 23, 2024)

BEGINNING AT THE NORTHWEST CORNER OF WILLIAM M. KINCAID DONATION LAND CLAIM IN SECTION 24, TOWNSHIP 20 NORTH, RANGE 4 EAST, WILLAMETTE MERIDIAN, IN PIERCE COUNTY, WASHINGTON; THENCE SOUTH ALONG THE WEST LINE OF SAID DONATION LAND CLAIM TO INTERSECT WITH THE SUMNER CITY BOUNDARY LINE AND THE TRUE POINT OF BEGINNING; THENCE CONTINUE SOUTH ON THE SAME LINE, 660 FEET TO INTERSECT WITH SAID SUMNER CITY BOUNDARY LINE; THENCE ALONG SAID BOUNDARY NORTH 14°00'00" WEST 460 FEET AND NORTH 31°00'00" EAST, 240 FEET TO THE POINT OF BEGINNING, ALL IN THE STUCK RIVER.

03/11/26



SW 1/4, SEC. 24, T. 20 N., R. 4 E., W.M.

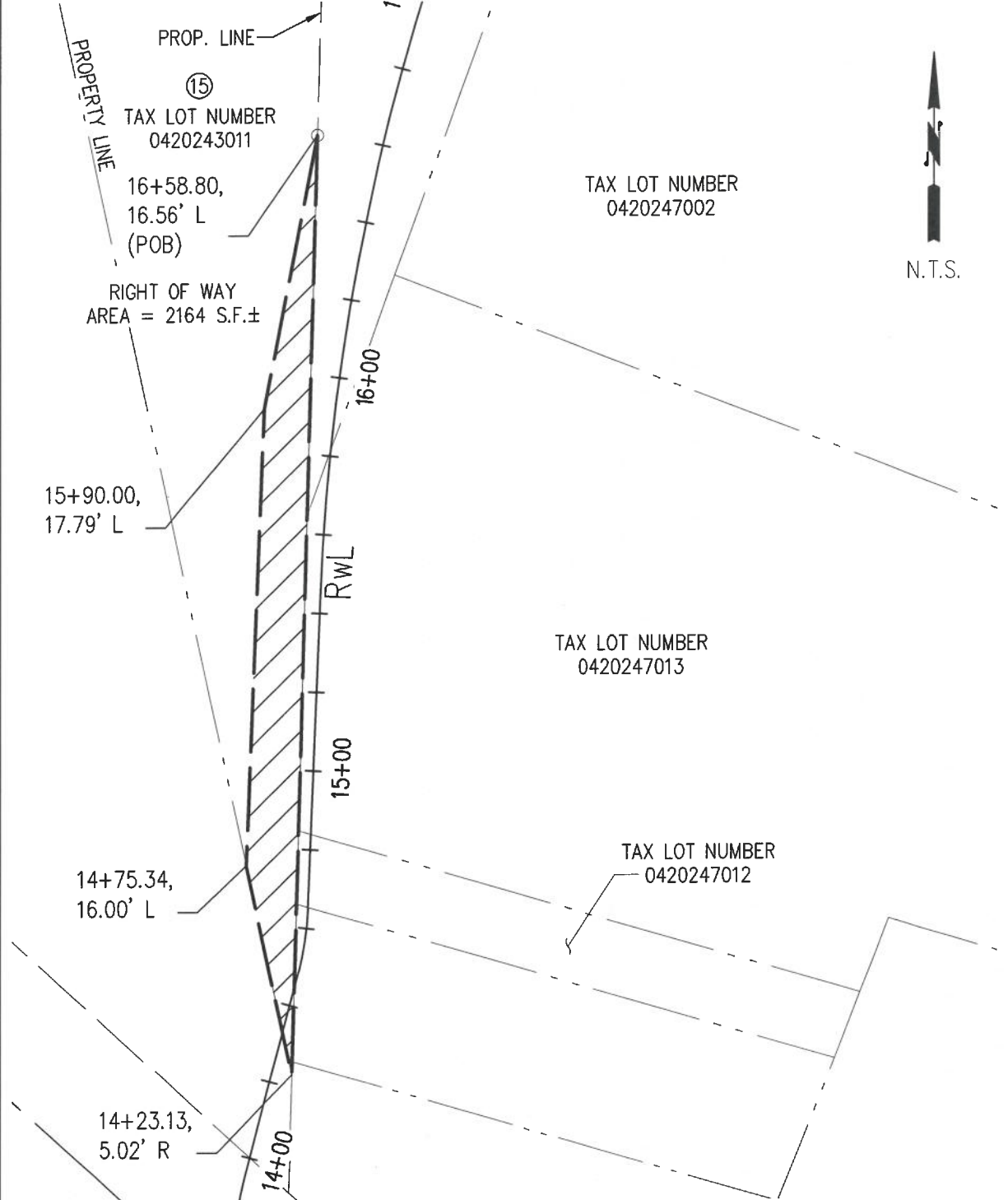

PROP. LINE  
 ⑮  
 TAX LOT NUMBER  
 0420243011  
 16+58.80,  
 16.56' L  
 (POB)  
 RIGHT OF WAY  
 AREA = 2164 S.F.±

TAX LOT NUMBER  
0420247002



15+90.00,  
17.79' L

TAX LOT NUMBER  
0420247013

14+75.34,  
16.00' L

TAX LOT NUMBER  
0420247012

14+23.13,  
5.02' R

DATE: MARCH 10, 2026

FILE: 15.DWG



**Seattle**  
 3131 Elliott Avenue, Suite 400  
 Seattle, WA 98121 206.286.1640  
 Tacoma | Wenatchee | KPG.com

EXHIBIT B  
 PARCEL 0420243011  
 RIGHT OF WAY ACQUISITION

Page 5 of 5 Pages

After recording return document to:

City of Sumner  
1104 Maple Street  
Sumner, WA 98390

**Document Title: Temporary Easement**  
**Grantor: Pierce County**  
**Grantee: City of Sumner**  
**Legal Description: Ptn. NE 1/4 of SW 1/4 of S24, T20N, R04E.W.M.**  
**Additional Legal Description is on Page 4 and 5 of Document.**  
**Assessor's Tax Parcel Number: 0420243011**

## **TEMPORARY EASEMENT**

### **CITY OF SUMNER FRYAR AVENUE SHARED USE TRAIL**

The Grantor, Pierce County, a Washington municipal corporation and a legal subdivision of the State of Washington, who acquired title as Pierce County, a political subdivision of the State of Washington, for and in consideration of TEN AND NO/100 (\$10.00) DOLLARS, and other valuable consideration, conveys and grants unto the City of Sumner, and its assigns, Grantee, the right, privilege and easement over, upon, and across the hereinafter described lands for the purpose of ingress, egress, for any and all purposes incidental to constructing, installing, and inspecting slopes, walls, sidewalks, curbs, gutters, drainage and other related road and utility construction activities, including driveway reconnection.

Said lands being situated in Pierce County, State of Washington, and described in Exhibit A and depicted in B, attached hereto, and made a part hereof.

The term of this Temporary Easement shall commence on the date of acceptance of this Temporary Easement by Grantee and shall terminate on January 31, 2027, hereinafter the "Term".

Grantee shall provide Grantor written notice no less than 14 days in advance of Grantee's intent to exercise its rights under this Temporary Easement.

**TEMPORARY EASEMENT**

It is further agreed that this Temporary Easement may be extended by up to one (1) year at the Grantee's option. The rate associated with this extension shall be at the same rate as the original Temporary Easement, or at the newly established rate determined by an updated waiver valuation; whichever is higher. Grantee shall notify Grantor in writing, and render payment, prior to exercising this option.

All project improvements shall be constructed entirely within the public right of way. In the event improvements in the Easement Area are disturbed or damaged by Grantee's use of the Easement, on or before the end of the Term, Grantee shall restore or replace in as good or better condition as they were immediately before Grantee entered the Easement Area. During the Term, Grantee may on an interim basis, restore the Easement Area to a reasonably safe and convenient condition.

It is understood and agreed that delivery of this temporary easement is hereby tendered and that the terms and obligations hereof shall not become binding upon the City of Sumner unless and until accepted and approved hereon in writing for the City of Sumner, by its authorized agent.

Dated: April 8, 2020

  
Name: Bryan W. Mello  
Title: Pierce County Executive

\_\_\_\_\_  
Name:  
Title:

Accepted and Approved

City of Sumner

By: \_\_\_\_\_  
Carla S. Bowman  
Mayor of the City of Sumner

Date: \_\_\_\_\_

**TEMPORARY EASEMENT**

**ACKNOWLEDGMENT**

STATE OF WASHINGTON )

County of Pierce )

On this 8 day of April, 2024, before me, the undersigned, a Notary Public in and for the State of Washington, duly commissioned and sworn, personally appeared Ryan N. Mello, to me known to be the Executive, respectively of PIERCE COUNTY, the corporation that executed the foregoing instrument, and acknowledged the said instrument to be the free and voluntary act and deed of said corporation, for the uses and purposes therein mentioned, and on oath stated that he/she is authorized to execute the said instrument and that the seal affixed (if any) is the corporate seal of said corporation.

WITNESS my hand and official seal hereto affixed the day and year first written above.



Lisa Carasella  
(Print Name)

Lisa Carasella  
Notary Public in and for the State of Washington  
Residing at Tacoma, WA

My Appointment Expires:

12/15/2029

APPROVED as to form only:

DPA Northrip approved as to form by 3/19/2026 email  
Pierce County Deputy Prosecuting Attorney

**EXHIBIT A**  
**PARCEL NO. 0420243011**  
**TEMPORARY CONSTRUCTION EASEMENT**

THAT PORTION OF THE HEREINAFTER DESCRIBED PARCEL "A", DESCRIBED AS FOLLOWS:

BEGINNING AT A POINT OPPOSITE STATION Rwl 16+58.80, AS SHOWN ON SAID CITY OF SUMNER "FRYAR AVENUE SHARED USE TRAIL RIGHT OF WAY PLANS" ON FILE WITH THE CITY, 16.56 FEET WESTERLY THEREFROM;

THENCE SOUTHERLY IN A STRAIGHT LINE TO A POINT OPPOSITE STATION 15+90.00, 17.79 FEET WESTERLY THEREFROM;

THENCE SOUTHERLY IN A STRAIGHT LINE TO A POINT OPPOSITE STATION 14+75.34, 16.00 FEET WESTERLY THEREFROM;

THENCE NORTHWESTERLY IN A STRAIGHT LINE TO A POINT OPPOSITE STATION 15+06.16, 24.00 FEET WESTERLY THEREFROM;

THENCE NORTHERLY IN A STRAIGHT LINE TO A POINT OPPOSITE STATION 15+78.00, 25.00 FEET WESTERLY THEREFROM;

THENCE NORTHEASTERLY IN A STRAIGHT LINE TO A POINT OPPOSITE STATION 16+82.71, 22.17 FEET WESTERLY THEREFROM;

THENCE SOUTHERLY IN A STRAIGHT LINE TO THE POINT OF BEGINNING.

CONTAINING 1,223 SQUARE FEET, MORE OR LESS.

**PARCEL "A":**

(PER CHICAGO TITLE COMPANY ORDER NO. 242503, DATED JULY 23, 2024)

BEGINNING AT THE NORTHWEST CORNER OF WILLIAM M. KINCAID DONATION LAND CLAIM IN SECTION 24, TOWNSHIP 20 NORTH, RANGE 4 EAST, WILLAMETTE MERIDIAN, IN PIERCE COUNTY, WASHINGTON; THENCE SOUTH ALONG THE WEST LINE OF SAID DONATION LAND CLAIM TO INTERSECT WITH THE SUMNER CITY BOUNDARY LINE AND THE TRUE POINT OF BEGINNING; THENCE CONTINUE SOUTH ON THE SAME LINE, 660 FEET TO INTERSECT WITH SAID SUMNER CITY BOUNDARY LINE; THENCE ALONG SAID BOUNDARY NORTH 14°00'00" WEST 460 FEET AND NORTH 31°00'00" EAST, 240 FEET TO THE POINT OF BEGINNING, ALL IN THE STUCK RIVER.

03/11/2026



SW 1/4, SEC. 24, T. 20 N., R. 4 E., W.M.

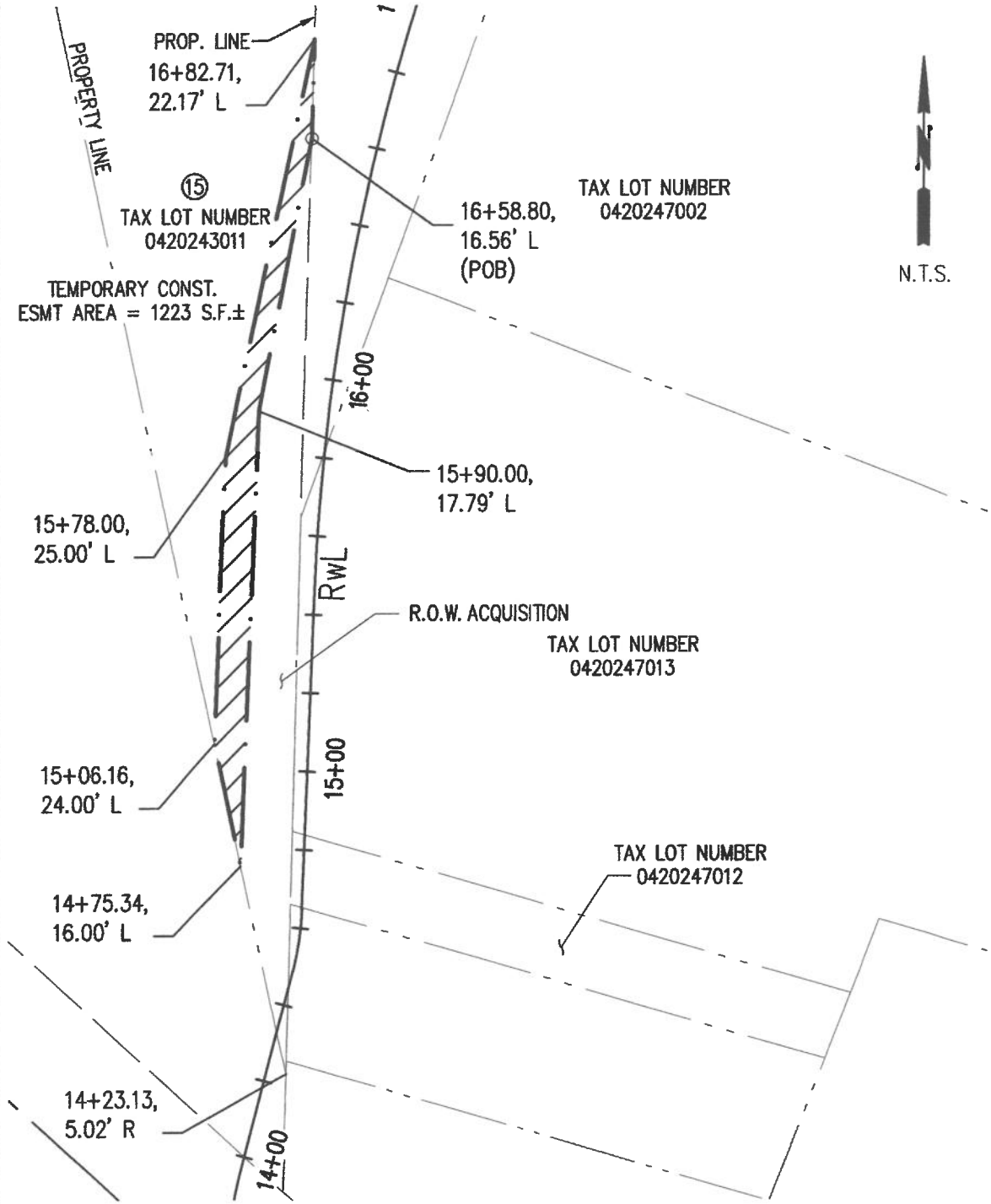

DATE: MARCH 11, 2026

FILE: 15.DWG

**KPG**  
PSOMAS

Seattle  
3131 Elliott Avenue, Suite 400  
Seattle, WA 98121 206.286.1640  
Tacoma | Wenatchee | KPG.com

EXHIBIT \_\_\_\_\_  
 PARCEL 0420243011  
 Page 5 of 5 Pages TEMPORARY CONSTRUCTION EASEMENT

---

**SUBJECT:** Valley Avenue Water System Improvements - Construction Contract Award

**CATEGORY:** Consent

---

**BUDGET IMPACT:**

Expenditure Required: \$760,026.16

Within Budget Allocation: Yes

---

**ATTACHMENTS:**

1. Valley Avenue Water System Improvements - Construction Contract and Bid Tab

**STAFF CONTACT:** Andrew Leach, Senior Associate City Engineer

---

**SUMMARY BACKGROUND:**

This project provides for the improvement of the City's existing water system on Valley Ave and SR 162, including installation of a 12-inch water main and casings, the abandonment of existing small-diameter water main, the relocation and re-connection of existing water meters and services, and the removal and replacement of three fire hydrant assemblies. Additional work includes improvements to the existing stormwater system and construction of two ADA-compliant curb ramps.

Two (2) bids were received on April 14th, 2026 for this project. The lowest responsible bid was submitted by HCON, Inc., with a bid amount of \$690,932.87. The Engineer's Estimate for this project was \$620,240.80. With the 10% contingency of \$69,093.29, the required expenditure is \$760,026.16. The project will be funded through a combination of water and storm utility funds.

The Contractor will have forty (40) working days after issuance of the Notice to Proceed to complete the project.

---

**COUNCIL COMMITTEE/STUDY SESSION:** Public Works Committee

**MEETING/STUDY SESSION DATE:** 4/21/2026

**COMMITTEE RECOMMENDATION:** Do Pass

**STAFF RECOMMENDATIONS/MOTION:**

A motion authorizing the Mayor and City Administrator to execute all necessary contract documents with HCON, Inc., in an amount not-to-exceed \$690,932.87 for the Valley Avenue Water System improvements (CIP 25-05), substantially in a form approved by the City Attorney.

**PUBLIC WORKS CONTRACT**  
**between City of Sumner and**  
**HCON Incorporated**

THIS AGREEMENT, made and entered into this day of \_\_\_\_\_, between the City of Sumner under and by virtue of Title 35 RCW (Cities and towns) as amended and HCON Incorporated, hereinafter called the Contractor.

WITNESSETH:

That in consideration of the terms and conditions contained herein and attached and made a part of this agreement, the parties hereto covenant and agree as follows:

I. The Contractor shall do all work and furnish all tools, materials and equipment for

Valley Ave Water System Improvements (CIP 25-05)

in accordance with and as described in the (a) attached plans and specifications, (b) the standard specifications of the Washington State Department of Transportation, and (c) all other documents, specifications, provisions and required regulations contained in the Bid Document package provided at bid opening, all of which are considered the "Contract Documents" and are incorporated herein by this reference and made part hereof as if fully set forth in this contract, and, shall perform any changes in the work in accord with the Contract Documents.

The Contractor shall provide and bear the expense of all equipment, work and labor, of any sort whatsoever that may be required for the transfer of materials and for constructing and completing the work provided for in these Contract Documents except those items mentioned therein to be furnished by the City of Sumner.

II. The City of Sumner hereby promises and agrees with the Contractor to employ, and does employ the Contractor to provide the materials and to do and cause to be done the above described work and to complete and finish the same in accord with the attached plans and specifications and the terms and conditions herein contained and hereby contracts to pay for the same according to the attached specifications and the schedule of unit or itemized prices at the time and in the manner upon the conditions provided for in this contract. The Contractor for himself/herself, and for his/her heirs, executors, administrators, successors, and kin, does hereby agree to the full performance of all the covenants herein contained upon the part of the Contractor.

III. **Insurance and Indemnity.** The following insurance and indemnification provisions shall apply to all of the above described work.

The Contractor shall defend, indemnify and hold the Public Entity, its officers, officials, employees and volunteers harmless from any and all claims, injuries, damages, losses or suits including attorney fees, arising out of or in connection with the performance of this Agreement, except for injuries and damages caused by the sole negligence of the Public Entity.

Should a court of competent jurisdiction determine that this Agreement is subject to RCW 4.24.115, then, in the event of liability for damages arising out of bodily injury to persons or damages to property caused by or resulting from the concurrent negligence of the Contractor and the Public Entity, its officers, officials, employees, and volunteers, the Contractor's liability hereunder shall be only to the extent of the Contractor's negligence. It is further specifically and expressly understood that the indemnification provided herein constitutes the Contractor's waiver of immunity under Industrial Insurance, Title 51 RCW, solely for the purposes of this indemnification. This waiver has been mutually negotiated by the parties. The provisions of this section shall survive the expiration or termination of this Agreement.

#### **A. Insurance Term**

The Contractor shall procure and maintain insurance, as required in this Section, without interruption from commencement of the Contractor's work through the term of the contract and for thirty (30) days after the Physical Completion date, unless otherwise indicated herein.

#### **B. No Limitation**

The Contractor's maintenance of insurance, its scope of coverage and limits as required herein shall not be construed to limit the liability of the Contractor to the coverage provided by such insurance, or otherwise limit the Public Entity's recourse to any remedy available at law or in equity.

#### **C. Minimum Scope of Insurance**

The Contractor's required insurance shall be of the types and coverage as stated below:

1. Automobile Liability insurance covering all owned, non-owned, hired and leased vehicles. Coverage shall be at least as broad as Insurance Services Office (ISO) form CA 00 01.
2. Commercial General Liability insurance shall be at least as broad as ISO occurrence form CG 00 01 and shall cover liability arising from premises, operations, stop gap liability, independent contractors, products-completed operations, personal injury and advertising injury, and liability assumed under an insured contract. The Commercial General Liability insurance shall be endorsed to provide a per project general aggregate limit, using ISO form CG 25 03 05 09 or an equivalent endorsement. There shall be no exclusion for liability arising from explosion, collapse or underground property damage. The Public Entity shall be named as an additional insured under the Contractor's Commercial General Liability insurance policy with respect to the work performed for the Public Entity using ISO Additional Insured endorsement CG 20 10 10 01 and Additional Insured-Completed Operations endorsement CG 20 37 10 01 or substitute endorsements providing at least as broad coverage.

3. Workers' Compensation coverage as required by the Industrial Insurance laws of the State of Washington.
4. Builders Risk insurance covering interests of the Public Entity, the Contractor, Subcontractors, and Sub-subcontractors in the work. Builders Risk insurance shall be on a special perils policy form and shall insure against the perils of fire and extended coverage and physical loss or damage including flood, earthquake, theft, vandalism, malicious mischief, and collapse. The Builders Risk insurance shall include coverage for temporary buildings, debris removal, and damage to materials in transit or stored off-site. This Builders Risk insurance covering the work will have a deductible of \$5,000 for each occurrence, which will be the responsibility of the Contractor. Higher deductibles for flood and earthquake perils may be accepted by the Public Entity upon written request by the Contractor and written acceptance by the Public Entity. Any increased deductibles accepted by the Public Entity will remain the responsibility of the Contractor. The Builders Risk insurance shall be maintained until the Public Entity has granted substantial completion of the project. An installation floater may be acceptable in lieu of Builders Risk for renovation projects only if approved in writing by the Public Entity.

#### **D. Minimum Amounts of Insurance**

The Contractor shall maintain the following insurance limits:

1. Automobile Liability insurance with a minimum combined single limit for bodily injury and property damage of \$1,000,000 per accident.
2. Commercial General Liability insurance shall be written with limits no less than \$2,000,000 each occurrence, \$2,000,000 general aggregate and a \$2,000,000 products-completed operations aggregate limit.
3. Builders Risk insurance shall be written in the amount of the completed value of the project with no coinsurance provisions.

#### **E. Public Entity Full Availability of Contractor Limits**

If the Contractor maintains higher insurance limits than the minimums shown above, the Public Entity shall be insured for the full available limits of Commercial General and Excess or Umbrella liability maintained by the Contractor, irrespective of whether such limits maintained by the Contractor are greater than those required by this contract or whether any certificate of insurance furnished to the Public Entity evidences limits of liability lower than those maintained by the Contractor.

#### **F. Other Insurance Provision**

The Contractor's Automobile Liability, Commercial General Liability and Builders Risk insurance policies are to contain, or be endorsed to contain that they shall be primary insurance as respect the Public Entity. Any insurance, self-insurance, or self-insured pool coverage maintained by the Public Entity shall be excess of the Contractor's insurance and shall not contribute with it.

### **G. Contractor's Insurance for Other Losses**

The Contractor shall assume full responsibility for all loss or damage from any cause whatsoever to any tools, Contractor's employee owned tools, machinery, equipment, or motor vehicles owned or rented by the Contractor, or the Contractor's agents, suppliers, contractors or subcontractors as well as to any temporary structures, scaffolding and protective fences.

### **H. Waiver of Subrogation**

The Contractor and the Public Entity waive all rights against each other, any of their Subcontractors, Sub-subcontractors, agents and employees, each of the other, for damages caused by fire or other perils to the extent covered by Builders Risk insurance or other property insurance obtained pursuant to the Insurance Requirements Section of this Contract or other property insurance applicable to the work. The policies shall provide such waivers by endorsement or otherwise.

### **I. Acceptability of Insurers**

Insurance is to be placed with insurers with a current A.M. Best rating of not less than A: VII.

### **J. Verification of Coverage**

The Contractor shall furnish the Public Entity with original certificates and a copy of the amendatory endorsements, including but not necessarily limited to the additional insured endorsements, evidencing the Automobile Liability and Commercial General Liability insurance of the Contractor before commencement of the work. Before any exposure to loss may occur, the Contractor shall file with the Public Entity a copy of the Builders Risk insurance policy that includes all applicable conditions, exclusions, definitions, terms and endorsements related to this project. Upon request by the Public Entity, the Contractor shall furnish certified copies of all required insurance policies, including endorsements, required in this contract and evidence of all subcontractors' coverage.

### **K. Subcontractors**

The Contractor shall cause each and every Subcontractor to provide insurance coverage that complies with all applicable requirements of the Contractor-provided insurance as set forth herein, except the Contractor shall have sole responsibility for determining the limits of coverage required to be obtained by Subcontractors. The Contractor shall ensure that the Public Entity is an additional insured on each and every Subcontractor's Commercial General liability insurance policy using an endorsement as least as broad as ISO CG 20 10 10 01 for ongoing operations and CG 20 37 10 01 for completed operations.

### **L. Notice of Cancellation**

The Contractor shall provide the Public Entity and all Additional Insureds for this work with written notice of any policy cancellation within two business days of their receipt of such notice.

### **M. Failure to Maintain Insurance**

Failure on the part of the Contractor to maintain the insurance as required shall constitute a material breach of contract, upon which the Public Entity may, after giving five business days' notice to the Contractor to correct the breach, immediately terminate the contract or, at its discretion, procure or renew such insurance and pay any and all premiums in connection therewith, with any sums so expended to be repaid to the Public Entity on demand, or at the sole discretion of the Public Entity, offset against funds due the Contractor from the Public Entity.

#### **N. Additional Insurance**

All insurance policies, with the exception of Workers Compensation, and of Professional Liability and Builder's Risk (if required by this Contract) shall name the following listed entities as additional insured(s) using the forms or endorsements required herein:

- the Contracting Agency and its officers, elected officials, employees, agents, and volunteers

The above-listed entities shall be additional insured(s) for the full available limits of liability maintained by the Contractor, irrespective of whether such limits maintained by the Contractor are greater than those required by this Contract, and irrespective of whether the Certificate of Insurance provided by the Contractor pursuant to describes limits lower than those maintained by the Contractor.

For Commercial General Liability insurance coverage, the required additional insured endorsements shall be at least as broad as ISO forms CG 20 10 10 01 for ongoing operations and CG 20 37 10 01 for completed operations.

#### **IV. Contractor's Employees – Employment Eligibility Requirements (E-Verify).**

The Contractor and any subcontractors shall comply with E-Verify as set forth in Sumner Municipal Code Chapter 3.30. E-Verify is an Internet-based system operated by United States Citizenship and Immigration Services in partnership with the Social Security Administration. E-Verify is free to employers and is available in all 50 states. E-Verify provides an automated link to federal databases to help employers determine employment eligibility of new hires and the validity of their Social Security numbers. The Contractor shall enroll in, participate in and document use of E-Verify as a condition of the award of this contract. The Contractor shall continue participation in E-Verify throughout the course of the Contractor's contractual relationship with the City. If the Contractor uses or employs any subcontractor in the performance of work under this contract, or any subsequent renewals, modifications or extension of this contract, the subcontractor shall register in and participate in E-Verify and certify such participation to the Contractor. Upon execution of this Contract, the Contractor shall provide proof of compliance with this section by filling out and signing the attached Certification of Compliance with Sumner's Municipal Code 3.30 "E-Verify" attached hereto as Exhibit B.

V. It is further provided that no liability shall attach to the City of Sumner by reason of entering into this contract except as provided herein.

VI. Debarment. The Contractor must certify that it, and its subcontractors, have not been and are not currently on the Federal or the Washington State Debarment List and if the

Contractor or its subcontractors become listed on the Federal or State Debarment List, the City will be notified immediately.

VII. Application of Uniform Guidance. If this contract involves the use, in whole or in part, of federal award(s), provisions (A)-(J) in Appendix II to Part 200 of the Uniform Guidance (2 CFR Ch. 11 (1-1-14 edition)) are hereby incorporated, as applicable, as if fully set forth herein. See attached Exhibit C.

IN WITNESS WHEREOF, the Contractor has executed this instrument, on the day and year first below written and the Local Agency Approving Authority has caused this instrument to be executed by and in the name of said City of Sumner the day and year first above written.

<p><b>CONTRACTOR:</b></p> <p>By: _____ <i>(signature)</i></p> <p>Print Name: _____</p> <p>Title: _____ <i>(Title)</i></p> <p>DATE: _____</p>	<p><b>CITY OF SUMNER:</b></p> <p>By: _____ <i>(signature)</i></p> <p>Print Name: <u>Carla S. Bowman</u> Its <u>Mayor</u> <i>(Title)</i></p> <p>DATE: _____</p> <p>By: _____ <i>(signature)</i></p> <p>Print Name: <u>Jason Wilson</u> Its <u>City Administrator</u> <i>(Title)</i></p> <p>DATE: _____</p> <p>Attest: _____ Approved as to form: _____</p> <p>City Clerk _____ City Attorney _____ DATE: _____ DATE: _____</p>
<p><b>NOTICES TO BE SENT TO:</b></p> <p><b>CONTRACTOR:</b></p> <p>Josh Helm HCON Incorporated P.O. Box 731005 Puyallup, WA 98373 253-268-3060 (telephone) jhelm@hconinc.com (email)</p>	<p><b>NOTICES TO BE SENT TO:</b></p> <p><b>CITY OF SUMNER:</b></p> <p>Andrew Leach, Senior Associate City Engineer City of Sumner 1104 Maple Street Sumner, WA 98390 253-299-5711 (telephone) andrewl@sumnerwa.gov (email)</p>

EXHIBIT A  
Scope and Schedule of Work

**PROPOSAL – SIGNATURE PAGE**

The bidder is hereby advised that by signature of this proposal he/she is deemed to have acknowledged all requirements and signed all certificates contained herein.

A proposal guaranty in an amount of five percent (5%) of the total bid, based upon the approximate estimate of quantities at the above prices and in the form as indicated below is attached hereto:

Cash  In the Amount of \_\_\_\_\_

Cashier's Check  \_\_\_\_\_ Dollars

Certified Check  (\$ \_\_\_\_\_ ) Payable to the City of Sumner

Proposal Bond  In the Amount of 5% of the Bid

Receipt is hereby acknowledged of addendum(s) No.(s) 1 , \_\_\_\_\_ , & \_\_\_\_\_

Signature of Authorized Official(s)

**Proposal Must be Signed**

→ \_\_\_\_\_  
Title:

HCON Incorporated President

Firm Name:

HCON Incorporated

Address:

PO Box 731005

Puyallup, WA 98373

Phone Number:

253-268-3060

Email:

jhelm@hconinc.com

State of Washington

Contractor's License No.:

HCONII\*820DM

Federal ID No.

82-4390058

UBI #

604-225-872

**Note:**

- (1) This proposal form is not transferable and any alteration of the firm's name entered hereon without prior permission from the City of Sumner will be cause for considering the proposal irregular and subsequent rejection of the bid.
- (2) Please refer to Section 1-02.6 of the standard specifications, re: "Preparation of Proposal," or "Item 6" of the Instruction to Bidders for building construction jobs.
- (3) Should it be necessary to modify this proposal either in writing or by electronic means, please make reference to the following proposal number in your communication: CIP 25-05.

**Valley Ave Water System Improvements – Schedule of Prices**

Item No.	Estimated Quantity	Unit	Description of Item	Section	Unit Cost	Amount
<b>Bid Schedule A – Water System Improvements</b>						
001	1	LS	Mobilization, Demobilization, Site Preparation, and Cleanup	Div. 10	\$ <u>31,000.00</u>	\$ <u>31,000.00</u>
002	1	LS	Construction Survey and As-Built Record Drawings	Div. 10	\$ <u>5,000.00</u>	\$ <u>5,000.00</u>
003	1	LS	Temporary Sedimentation and Erosion Control	Div. 10	\$ <u>1,000.00</u>	\$ <u>1,000.00</u>
004	6	EA	Potholing Existing Utilities	Div. 10	\$ <u>500.00</u>	\$ <u>3,000.00</u>
005	1	LS	Shoring and Trench Safety System	Div. 10	\$ <u>2,000.00</u>	\$ <u>2,000.00</u>
006	114	LF	12-Inch Ductile Iron Water Main	Div. 10	\$ <u>684.50</u>	\$ <u>78,033.00</u>
007	11	EA	Domestic Service Connections	Div. 10	\$ <u>5,713.00</u>	\$ <u>62,843.00</u>
008	170	LF	Service Line Extension	Div. 10	\$ <u>64.71</u>	\$ <u>11,000.70</u>
009	1	LS	Removal or Abandonment of Inactive Water System	Div. 10	\$ <u>30,350.00</u>	\$ <u>30,350.00</u>
010	50	LF	Disposal of Asbestos Cement Water Main	Div. 10	\$ <u>250.00</u>	\$ <u>12,500.00</u>
011	2	EA	6-Inch Gate Valve	Div. 10	\$ <u>1,572.50</u>	\$ <u>3,145.00</u>
012	6	EA	12-Inch Gate Valve	Div. 10	\$ <u>3,872.50</u>	\$ <u>23,235.00</u>
013	3	EA	Fire Hydrant Assembly	Div. 10	\$ <u>10,834.00</u>	\$ <u>32,502.00</u>
014	5	EA	Connection to Existing System	Div. 10	\$ <u>10,920.00</u>	\$ <u>54,600.00</u>
015	1	LS	Demolition	Div. 10	\$ <u>10,000.00</u>	\$ <u>10,000.00</u>
016	40	TN	Hot Mix Asphalt (HMA)	Div. 10	\$ <u>400.00</u>	\$ <u>16,000.00</u>
017	1,000	TN	Crushed Rock	Div. 10	\$ <u>25.00</u>	\$ <u>25,000.00</u>

018	1	FA	Site Restoration	Div. 10	\$10,000	\$10,000
019	1	LS	Traffic Control Plan and Temporary Roadway Closures	Div. 10	\$ <u>61,016.00</u>	\$ <u>61,016.00</u>
020	1	FA	Minor Change	Div. 10	\$20,000	\$20,000
<b>Subtotal</b>					\$ <u>492,224.70</u>	
9.6% Sales Tax (Per W.S. Revenue Rule No. 171)					\$ <u>47,253.57</u>	
<b>Bid Total</b>					\$ <u>539,478.27</u>	

HCON Incorporated

Contractor's Name

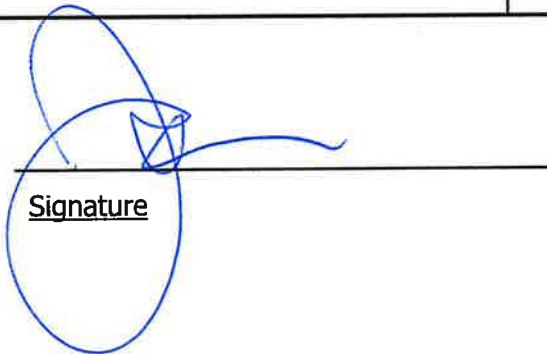

Signature

## Valley Ave Water System Improvements – Schedule of Prices

Item No.	Estimated Quantity	Unit	Description of Item	Section	Unit Cost	Amount
<b>Bid Schedule B – Roadway Improvements (Non-Taxable)</b>						
101	1	LS	Mobilization, Demobilization, Site Preparation, and Cleanup	Div. 10	\$3,000.00	\$3,000.00
102	1	LS	Construction Survey and As-Built Record Drawings	Div. 10	\$1,000.00	\$1,000.00
103	1	LS	Temporary Sedimentation and Erosion Control	Div. 10	\$500.00	\$500.00
104	1	LS	Demolition	Div. 10	\$6,400.00	\$6,400.00
105	2	EA	Parallel Curb Ramp (Type A)	Div. 10	\$3,986.50	\$7,973.00
106	50	TN	Hot Mix Asphalt (HMA)	Div. 10	\$500.00	\$25,000.00
107	150	SY	Cement Concrete Sidewalk	Div. 10	\$104.16	\$15,624.00
108	130	LF	Cement Concrete Traffic Curb and Gutter	Div. 10	\$60.52	\$7,867.60
109	1	LS	Thermo-plastic Traffic Markings	Div. 10	\$4,290.00	\$4,290.00
110	270	TN	Crushed Rock	Div. 10	\$25.00	\$6,750.00
111	1	FA	Roadway Site Restoration	Div. 10	\$10,000	\$10,000
112	1	LS	Traffic Control Plan and Temporary Roadway Closures	Div. 10	\$14,000.00	\$14,000.00
113	1	FA	Minor Change	Div. 10	\$20,000	\$20,000
<b>Subtotal</b>					\$122,404.60	
<b>Bid Total</b>					\$661,882.87	

HCON Incorporated

Contractor's Name

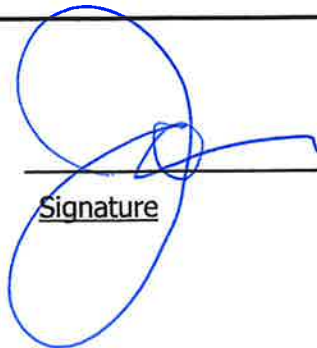

Signature

**Valley Ave Water System Improvements – Schedule of Prices**

Item No.	Estimated Quantity	Unit	Description of Item	Section	Unit Cost	Amount
<b>Bid Schedule C – Stormwater Improvements (Non-Taxable)</b>						
201	1	LS	Mobilization, Demobilization, Site Preparation, and Cleanup	Div. 10	\$ <u>1,000.00</u>	\$ <u>1,000.00</u>
202	1	LS	Construction Survey and As-Built Record Drawings	Div. 10	\$ <u>1,000.00</u>	\$ <u>1,000.00</u>
203	1	LS	Temporary Sedimentation and Erosion Control	Div. 10	\$ <u>500.00</u>	\$ <u>500.00</u>
204	2	EA	Potholing Existing Utilities	Div. 10	\$ <u>500.00</u>	\$ <u>1,000.00</u>
205	1	LS	Shoring and Trench Safety System	Div. 10	\$ <u>500.00</u>	\$ <u>500.00</u>
206	55	LF	12-Inch Stormwater Pipe	Div. 10	\$ <u>200.00</u>	\$ <u>11,000.00</u>
207	1	LS	Demolition	Div. 10	\$ <u>1,500.00</u>	\$ <u>1,500.00</u>
208	5	TN	Hot Mix Asphalt (HMA)	Div. 10	\$ <u>300.00</u>	\$ <u>1,500.00</u>
209	70	TN	Crushed Rock	Div. 10	\$ <u>25.00</u>	\$ <u>1,750.00</u>
210	1	LS	Traffic Control Plan and Temporary Roadway Closures	Div. 10	\$ <u>4,300.00</u>	\$ <u>4,300.00</u>
211	1	FA	Minor Change	Div. 10	\$5,000	\$5,000
<b>Subtotal</b>					\$ <u>29,050.00</u>	
<b>Bid Total</b>					\$ <u>690,932.87</u>	

HCON Incorporated

Contractor's Name

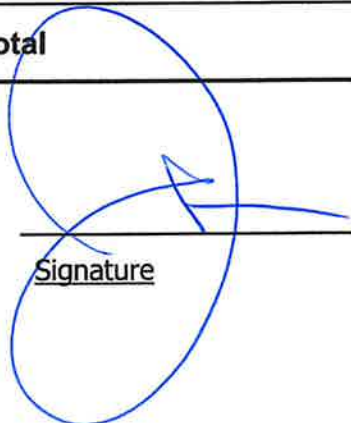

Signature

**EXHIBIT B**

CITY OF SUMNER

CERTIFICATION OF COMPLIANCE WITH SUMNER MUNICIPAL CODE CHAPTER 3.30  
“E-VERIFY“

As the person duly authorized to enter into such commitment for

**HCON Incorporated**

---

I hereby certify that the Company or Organization named herein will

(check one box below)

Be in compliance with all of the requirements of City of Sumner Municipal Code Chapter 3.30 for the duration of the contract entered into between the City of Sumner and the Company or Organization.

OR

Hire no employees for the term of the contract between the City and the Company or Organization.

---

NAME

---

TITLE

---

DATE

## EXHIBIT C

### APPENDIX II TO PART 200---CONTRACT PROVISIONS FOR NON-FEDERAL ENTITY CONTRACTS UNDER FEDERAL AWARDS

In addition to other provisions required by the Federal agency or non-Federal entity, all contracts made by the City of Sumner under federal award(s) are subject to the following provisions, as applicable.

**(A)** Contracts for more than the simplified acquisition threshold currently set at \$150,000, which is the inflation adjusted amount determined by the Civilian Agency Acquisition Council and the Defense Acquisition Regulations Council (Councils) as authorized by 41 U.S.C. 1908, must address administrative, contractual, or legal remedies in instances where contractors violate or breach contract terms, and provide for such sanctions and penalties as appropriate.

**(B)** All contracts in excess of \$10,000 must address termination for cause and for convenience by the non-Federal entity including the manner by which it will be effected and the basis for settlement.

**(C)** Equal Employment Opportunity. Pursuant to applicable federal law, federal regulations and/ or a final and binding Presidential Executive Order 11473, all federally funded construction project contractors shall ensure compliance with federal antidiscrimination laws, including the Equal Employment Opportunity regulations as currently written or subsequently modified or repealed.

**(D)** Davis-Bacon Act, as amended (40 U.S.C. 3141-3148). When required by Federal program legislation, all prime construction contracts in excess of \$2,000 awarded by non-Federal entities must include a provision for compliance with the Davis-Bacon Act (40 U.S.C. 3141-3144, and 3146-3148) as supplemented by Department of Labor regulations (29 CFR Part 5, "Labor Standards Provisions Applicable to Contracts Covering Federally Financed and Assisted Construction"). In accordance with the statute, the following language is hereby incorporated into the contract as if fully set forth therein:

Application of Uniform Guidance. If this contract involves the use, in whole or in part, of federal award(s), the following provisions (29 CFR, Subtitle A Part 5, Subpart A, § 5.5, subsections (a)(1)

- (a)(10) shall apply:
  - (1) Minimum wages.

(i) All laborers and mechanics employed or working upon the site of the work (or under the United States Housing Act of 1937 or under the Housing Act of 1949 in the construction or development of the project), will be paid unconditionally and not less often than once a week, and without subsequent deduction or rebate on any account (except such payroll deductions as are permitted by regulations issued by the Secretary of Labor under the Copeland Act ( 29 CFR part 3)), the full amount of wages and bona fide fringe benefits (or cash equivalents thereof) due at time of payment computed at rates not less than those contained in the wage determination of the Secretary of Labor which is attached hereto and made a part hereof, regardless of any contractual relationship which may be alleged to exist between the contractor and such laborers and mechanics. Contributions made or costs reasonably anticipated for bona fide fringe benefits under section 1(b)(2) of the Davis-Bacon Act on behalf of laborers or mechanics are considered wages paid to such laborers or mechanics, subject to the provisions of paragraph (a)(1)(iv) of this section; also, regular contributions made or costs incurred for more than a weekly period (but not less often than quarterly) under plans, funds, or programs which cover the particular weekly period, are deemed to be constructively made or incurred during such weekly period. Such laborers and mechanics shall be paid the appropriate wage rate and fringe benefits on the wage determination for the classification of work actually performed, without regard to skill, except as provided in § 5.5(a)(4). Laborers or mechanics performing work in more than one classification may be compensated at the rate specified for each classification for the time actually worked therein: Provided, That the employer's

payroll records accurately set forth the time spent in each classification in which work is performed. The wage determination (including any additional classification and wage rates conformed under paragraph (a)(1)(ii) of this section) and the Davis-Bacon poster (WH-1321) shall be posted at all times by the contractor and its subcontractors at the site of the work in a prominent and accessible place where it can be easily seen by the workers.

(ii)

(A) The contracting officer shall require that any class of laborers or mechanics, including helpers, which is not listed in the wage determination and which is to be employed under the contract shall be classified in conformance with the wage determination. The contracting officer shall approve an additional classification and wage rate and fringe benefits therefore only when the following criteria have been met:

(1) The work to be performed by the classification requested is not performed by a classification in the wage determination; and

(2) The classification is utilized in the area by the construction industry; and

(3) The proposed wage rate, including any bona fide fringe benefits, bears a reasonable relationship to the wage rates contained in the wage determination.

(B) If the contractor and the laborers and mechanics to be employed in the classification (if known), or their representatives, and the contracting officer agree on the classification and wage rate (including the amount designated for fringe benefits where appropriate), a report of the action taken shall be sent by the contracting officer to the Administrator of the Wage and Hour Division, U.S. Department of Labor, Washington, DC 20210. The Administrator, or an authorized representative, will approve, modify, or disapprove every additional classification action within 30 days of receipt and so advise the contracting officer or will notify the contracting officer within the 30-day period that additional time is necessary.

(C) In the event the contractor, the laborers or mechanics to be employed in the classification or their representatives, and the contracting officer do not agree on the proposed classification and wage rate (including the amount designated for fringe benefits, where appropriate), the contracting officer shall refer the questions, including the views of all interested parties and the recommendation of the contracting officer, to the Administrator for determination. The Administrator, or an authorized representative, will issue a determination within 30 days of receipt and so advise the contracting officer or will notify the contracting officer within the 30-day period that additional time is necessary.

(D) The wage rate (including fringe benefits where appropriate) determined pursuant to paragraphs (a)(1)(ii) (B) or (C) of this section, shall be paid to all workers performing work in the classification under this contract from the first day on which work is performed in the classification.

(iii) Whenever the minimum wage rate prescribed in the contract for a class of laborers or mechanics includes a fringe benefit which is not expressed as an hourly rate, the contractor shall either pay the benefit as stated in the wage determination or shall pay another bona fide fringe benefit or an hourly cash equivalent thereof.

(iv) If the contractor does not make payments to a trustee or other third person, the contractor may consider as part of the wages of any laborer or mechanic the amount of any costs reasonably anticipated in providing bona fide fringe benefits under a plan or program, Provided, That the Secretary of Labor has found, upon the written request of the contractor, that the applicable standards of the Davis-Bacon Act have been met. The Secretary of Labor may require the contractor to set aside in a separate account assets for the meeting of obligations under the plan or program.

(2) Withholding. The City of Sumner shall upon its own action or upon written request of an authorized representative of the Department of Labor withhold or cause to be withheld from the contractor under this contract or any other Federal contract with the same prime contractor, or any other federally-assisted contract subject to Davis-Bacon prevailing wage requirements, which is held by the same prime contractor, so much of the accrued payments or advances as may be considered necessary to pay laborers and mechanics, including apprentices, trainees, and helpers, employed by the contractor or any subcontractor the full amount of wages required by the contract. In the event of failure to pay any laborer or mechanic, including any apprentice, trainee,

or helper, employed or working on the site of the work (or under the United States Housing Act of 1937 or under the Housing Act of 1949 in the construction or development of the project), all or part of the wages required by the contract, the (Agency) may, after written notice to the contractor, sponsor, applicant, or owner, take such action as may be necessary to cause the suspension of any further payment, advance, or guarantee of funds until such violations have ceased.

(3) Payrolls and basic records.

(i) Payrolls and basic records relating thereto shall be maintained by the contractor during the course of the work and preserved for a period of three years thereafter for all laborers and mechanics working at the site of the work (or under the United States Housing Act of 1937, or under the Housing Act of 1949, in the construction or development of the project). Such records shall contain the name, address, and social security number of each such worker, his or her correct classification, hourly rates of wages paid (including rates of contributions or costs anticipated for bona fide fringe benefits or cash equivalents thereof of the types described in section 1(b)(2)(B) of the Davis-Bacon Act), daily and weekly number of hours worked, deductions made and actual wages paid. Whenever the Secretary of Labor has found under 29 CFR 5.5(a)(1)(iv) that the wages of any laborer or mechanic include the amount of any costs reasonably anticipated in providing benefits under a plan or program described in section 1(b)(2)(B) of the Davis-Bacon Act, the contractor shall maintain records which show that the commitment to provide such benefits is enforceable, that the plan or program is financially responsible, and that the plan or program has been communicated in writing to the laborers or mechanics affected, and records which show the costs anticipated or the actual cost incurred in providing such benefits. Contractors employing apprentices or trainees under approved programs shall maintain written evidence of the registration of apprenticeship programs and certification of trainee programs, the registration of the apprentices and trainees, and the ratios and wage rates prescribed in the applicable programs.

(ii) (A) The contractor shall submit weekly for each week in which any contract work is performed a copy of all payrolls to the City if the agency is a party to the contract, but if the agency is not such a party, the contractor will submit the payrolls to the applicant, sponsor, or owner, as the case may be, for transmission to the City. The payrolls submitted shall set out

accurately and completely all of the information required to be maintained under 29 CFR 5.5(a)(3)(i), except that full social security numbers and home addresses shall not be included on weekly transmittals. Instead the payrolls shall only need to include an individually identifying number for each employee (e.g., the last four digits of the employee's social security number). The required weekly payroll information may be submitted in any form desired. Optional Form WH-347 is available for this purpose from the Wage and Hour Division Web site at <http://www.dol.gov/esa/whd/forms/wh347instr.htm> or its successor site. The prime contractor is responsible for the submission of copies of payrolls by all subcontractors. Contractors and subcontractors shall maintain the full social security number and current address of each covered worker, and shall provide them upon request to the City if the agency is a party to the contract, but if the agency is not such a party, the contractor will submit them to the applicant, sponsor, or owner, as the case may be, for transmission to the City, the contractor, or the Wage and Hour Division of the Department of Labor for purposes of an investigation or audit of compliance with prevailing wage requirements. It is not a violation of this section for a prime contractor to require a subcontractor to provide addresses and social security numbers to the prime contractor for its own records, without weekly submission to the sponsoring government agency (or the applicant, sponsor, or owner).

(B) Each payroll submitted shall be accompanied by a "Statement of Compliance," signed by the contractor or subcontractor or his or her agent who pays or supervises the payment of the persons employed under the contract and shall certify the following:

(1) That the payroll for the payroll period contains the information required to be provided under § 5.5 (a)(3)(ii) of Regulations, 29 CFR part 5, the appropriate information is being maintained under § 5.5 (a)(3)(i) of Regulations, 29 CFR part 5, and that such information is correct and complete;

(2) That each laborer or mechanic (including each helper, apprentice, and trainee) employed on the contract during the payroll period has been paid the full weekly wages earned, without rebate, either directly or indirectly, and that no deductions have been made either directly or indirectly from the full wages earned, other than permissible deductions as set forth in Regulations, 29 CFR part 3;

(3) That each laborer or mechanic has been paid not less than the applicable wage rates and fringe benefits or cash equivalents for the classification of work performed, as specified in the applicable wage determination incorporated into the contract.

(C) The weekly submission of a properly executed certification set forth on the reverse side of Optional Form WH-347 shall satisfy the requirement for submission of the "Statement of Compliance" required by paragraph (a)(3)(ii)(B) of this section.

(D) The falsification of any of the above certifications may subject the contractor or subcontractor to civil or criminal prosecution under section 1001 of title 18 and section 231 of title 31 of the United States Code.

(iii) The contractor or subcontractor shall make the records required under paragraph (a)(3)(i) of this section available for inspection, copying, or transcription by authorized representatives of the City or the Department of Labor, and shall permit such representatives to interview employees during working hours on the job. If the contractor or subcontractor fails to submit the required records or to make them available, the Federal agency may, after written notice to the contractor, sponsor, applicant, or owner, take such action as may be necessary to cause the suspension of any further payment, advance, or guarantee of funds. Furthermore, failure to submit the required records upon request or to make such records available may be grounds for debarment action pursuant to 29 CFR 5.12.

(4) Apprentices and trainees.

(i) Apprentices. Apprentices will be permitted to work at less than the predetermined rate for the work they performed when they are employed pursuant to and individually registered in a bona fide apprenticeship program registered with the U.S. Department of Labor, Employment and Training Administration, Office of Apprenticeship Training, Employer and Labor Services, or with a State Apprenticeship Agency recognized by the Office, or if a person is employed in his or her first 90 days of probationary employment as an apprentice in such an apprenticeship program, who is not individually registered in the program, but who has been certified by the Office of Apprenticeship Training, Employer and Labor Services or a State Apprenticeship Agency (where appropriate) to be eligible for probationary employment as an apprentice. The allowable ratio of apprentices to journeymen on the job site in any craft classification shall not be greater than the ratio permitted to the contractor as to the entire work force under the registered program. Any worker listed on a payroll at an apprentice wage rate, who is not registered or otherwise employed as stated above, shall be paid not less than the applicable wage rate on the wage determination for the classification of work actually performed. In addition, any apprentice performing work on the job site in excess of the ratio permitted under the registered program shall be paid not less than the applicable wage rate on the wage determination for the work actually performed. Where a contractor is performing construction on a project in a locality other than that in which its program is registered, the ratios and wage rates (expressed in percentages of the journeyman's hourly rate) specified in the contractor's or subcontractor's registered program shall be observed. Every apprentice must be paid at not less than the rate specified in the registered program for the apprentice's level of progress, expressed as a percentage of the journeymen hourly rate specified in the applicable wage determination. Apprentices shall be paid fringe benefits in accordance with the provisions of the apprenticeship program. If the apprenticeship program does not specify fringe benefits, apprentices must be paid the full amount of fringe benefits listed on the wage determination for the applicable classification. If the Administrator determines that a different practice prevails for the applicable apprentice classification, fringes shall be paid in accordance with that determination. In the event the Office of Apprenticeship Training, Employer and Labor Services, or a State Apprenticeship Agency recognized by the Office, withdraws approval of an apprenticeship program, the contractor will no longer be permitted to utilize apprentices at less than the applicable predetermined rate for the work performed until an acceptable program is approved.

(ii) Trainees. Except as provided in 29 CFR 5.16, trainees will not be permitted to work at less than the predetermined rate for the work performed unless they are employed pursuant to and individually registered in a program which has received prior approval, evidenced by formal certification by the U.S. Department of Labor, Employment and Training Administration. The ratio of trainees to journeymen on the job site shall not be greater than permitted under the plan approved by the Employment and Training Administration. Every trainee must be paid at not less than the rate specified in the approved program for the trainee's level of progress, expressed as a percentage of the journeyman hourly rate specified in the

applicable wage determination. Trainees shall be paid fringe benefits in accordance with the provisions of the trainee program. If the trainee program does not mention fringe benefits, trainees shall be paid the full amount of fringe benefits listed on the wage determination unless the Administrator of the Wage and Hour Division determines that there is an apprenticeship program associated with the corresponding journeyman wage rate on the wage determination which provides for less

than full fringe benefits for apprentices. Any employee listed on the payroll at a trainee rate who is not registered and participating in a training plan approved by the Employment and Training Administration shall be paid not less than the applicable wage rate on the wage determination for the classification of work actually performed. In addition, any trainee performing work on the job site in excess of the ratio permitted under the registered program shall be paid not less than the applicable wage rate on the wage determination for the work actually performed. In the event the Employment and Training Administration withdraws approval of a training program, the contractor will no longer be permitted to utilize trainees at less than the applicable predetermined rate for the work performed until an acceptable program is approved.

(iii) Equal employment opportunity. The utilization of apprentices, trainees and journeymen under this part shall be in conformity with federal antidiscrimination laws, including the Equal Employment Opportunity regulations as currently written or subsequently modified or repealed.

(5) Compliance with Copeland Act requirements. The contractor shall comply with the requirements of 29 CFR part 3, which are incorporated by reference in this contract.

(6) Subcontracts. The contractor or subcontractor shall insert in any subcontracts the clauses contained in 29 CFR 5.5(a)(1) through (10) and such other clauses as the City may by appropriate instructions require, and also a clause requiring the subcontractors to include these clauses in any lower tier subcontracts. The prime contractor shall be responsible for the compliance by any subcontractor or lower tier subcontractor with all the contract clauses in 29 CFR 5.5.

(7) Contract termination: debarment. A breach of the contract clauses in 29 CFR 5.5 may be grounds for termination of the contract, and for debarment as a contractor and a subcontractor as provided in 29 CFR 5.12.

(8) Compliance with Davis-Bacon and Related Act requirements. All rulings and interpretations of the Davis-Bacon and Related Acts contained in 29 CFR parts 1, 3, and 5 are herein incorporated by reference in this contract.

(9) Disputes concerning labor standards. Disputes arising out of the labor standards provisions of this contract shall not be subject to the general disputes clause of this contract. Such disputes shall be resolved in accordance with the procedures of the Department of Labor set forth in 29 CFR parts 5, 6, and 7.. Disputes within the meaning of this clause include disputes between the contractor (or any of its subcontractors) and the contracting agency, the U.S. Department of Labor, or the employees or their representatives.

(10) Certification of eligibility.

(i) By entering into this contract, the contractor certifies that neither it (nor he or she) nor any person or firm who has an interest in the contractor's firm is a person or firm ineligible to be awarded Government contracts by virtue of section 3(a) of the Davis- Bacon Act or 29 CFR 5.12(a)(1).

(ii) No part of this contract shall be subcontracted to any person or firm ineligible for award of a Government contract by virtue of section 3(a) of the Davis-Bacon Act or 29 CFR 5.12(a)(1).

(iii) The penalty for making false statements is prescribed in the U.S. Criminal Code, 18 U.S.C. 1001.

**(E)** Contract Work Hours and Safety Standards Act (40 U.S.C. 3701-3708). Where applicable, all contracts awarded by the non-Federal entity in excess of \$100,000 that involve the employment of mechanics or laborers must include a provision for compliance with 40 U.S.C. 3702 and 3704, as supplemented by Department of Labor regulations (29 CFR Part 5). Under 40 U.S.C. 3702 of the Act, each contractor must be required to compute the wages of every mechanic and laborer on the basis of a standard work week of 40 hours. Work in excess of the standard work week is permissible provided that the worker is compensated at a rate of not less than one and a half times the basic rate of pay for all hours worked in excess of 40 hours in the work week. The requirements of 40 U.S.C. 3704 are applicable to construction work and provide that no laborer or mechanic must be required to work in surroundings or under working conditions which are unsanitary, hazardous or dangerous. These requirements do not apply to the purchases of supplies or materials or articles ordinarily available on the open market, or contracts for transportation or transmission of intelligence.

**(F)** Rights to Inventions Made Under a Contract or Agreement. If the Federal award meets the definition of "funding agreement" under 37 CFR §401.2 (a) and the recipient or sub recipient wishes to enter into a contract with a small business firm or nonprofit organization regarding the substitution of parties, assignment or performance of experimental, developmental, or research work under that "funding agreement," the recipient or sub recipient must comply with the requirements of 37 CFR Part 401, "Rights to Inventions Made by Nonprofit Organizations and Small Business Firms Under Government Grants, Contracts and Cooperative Agreements," and any implementing regulations issued by the awarding agency.

**(G)** Clean Air Act (42 U.S.C. 7401-7671q.) and the Federal Water Pollution Control Act (33 U.S.C. 1251-1387), as amended-Contracts and sub grants of amounts in excess of \$150,000 must contain a provision that requires the non-Federal award to agree to comply with all applicable standards, orders or regulations issued pursuant to the Clean Air Act (42 U.S.C. 7401-7671q) and the Federal Water Pollution Control Act as amended (33 U.S.C. 1251-1387). Violations must be reported to the Federal awarding agency and the Regional Office of the Environmental Protection Agency (EPA).

**(H)** Mandatory standards and policies relating to energy efficiency which are contained in the state energy conservation plan issued in compliance with the Energy Policy and Conservation Act (42 U.S.C. 6201).

**(I)** Debarment and Suspension (Executive Orders 12549 and 12689)-A contract award (see 2 CFR 180.220) must not be made to parties listed on the government wide Excluded Parties List System in the System for Award Management (SAM), in accordance with the OMB guidelines at 2 CFR 180 that implement Executive Orders 12549 (3 CFR Part 1986 Comp., p. 189) and 12689 (3 CFR Part 1989 Comp., p. 235), "Debarment and Suspension." The Excluded Parties List System in SAM contains the names of parties debarred, suspended, or otherwise excluded by agencies, as well as parties declared ineligible under statutory or regulatory authority other than Executive Order 12549.

**(J)** Byrd Anti-Lobbying Amendment (31 U.S.C. 1352)-Contractors that apply or bid for an award of \$100,000 or more must file the required certification. Each tier certifies to the tier above that it will not and has not used Federal appropriated funds to pay any person or organization for influencing or attempting to influence an officer or employee of any agency, a member of Congress, officer or employee of Congress, or an employee of a member of Congress in connection with obtaining any Federal contract, grant or any other award covered by 31 U.S.C. 1352. Each tier must also disclose any lobbying with non-Federal funds that takes place in connection with obtaining any Federal award. Such disclosures are forwarded from tier to tier up to the non-Federal award.

## Bid Tabulation

		<b>Project Name:</b> Valley Ave Water System Improvements									
		<b>CIP No.:</b> 25-05									
		<b>Bid Opening Date:</b> April 14, 2026									
		<b>Notes:</b>		<b>Engineer's Estimate</b>		<b>Bidder #1</b>		<b>Bidder #2</b>			
		Indicates error corrected by PW dept		\$X,XXX.XX		HCON Inc.		NW Cascade, Inc.			
		Indicates Bidder modified Proposal		\$X,XXX.XX		P.O. Box 731005		P.O. Box 73399			
		Indicates Revision Due to Duplication		*		Puyallup, WA 98373		Puyallup, WA 98373			
		<b>Total Bid</b>		<b>\$620,240.80</b>		<b>Total Bid</b>		<b>\$690,932.87</b>			
		<b>Total Bid</b>		<b>\$877,663.34</b>		<b>Total Bid</b>		<b>\$877,663.34</b>			
Bid Item	Bid Item Description	Unit	Quant	Unit Price	Amount	Unit Price	Amount	Unit Price	Amount		
<b>Base Schedule A - Water System Improvements</b>											
1A	Mobilization, Demobilization, Site Preparation, and Cleanup	LS	1	\$36,000.00	\$36,000.00	\$31,000.00	\$31,000.00	\$38,150.00	\$38,150.00		
2A	Construction Survey and As-Built Record Drawings	LS	1	\$3,400.00	\$3,400.00	\$5,000.00	\$5,000.00	\$1,740.00	\$1,740.00		
3A	Temporary Sedimentation and Erosion Control	LS	1	\$3,400.00	\$3,400.00	\$1,000.00	\$1,000.00	\$11,000.00	\$11,000.00		
4A	Potholing Existing Utilities	EA	6	\$1,000.00	\$6,000.00	\$500.00	\$3,000.00	\$596.00	\$3,576.00		
5A	Shoring and Trench Safety System	LS	1	\$7,000.00	\$7,000.00	\$2,000.00	\$2,000.00	\$1,200.00	\$1,200.00		
6A	12-inch Ductile Iron Water Main	LF	114	\$250.00	\$28,500.00	\$684.50	\$78,033.00	\$560.00	\$63,840.00		
7A	Domestic Service Connections	EA	11	\$3,000.00	\$33,000.00	\$5,713.00	\$62,843.00	\$5,500.00	\$60,500.00		
8A	Service Line Extension	LF	170	\$75.00	\$12,750.00	\$64.71	\$11,000.70	\$18.00	\$3,060.00		
9A	Removal or Abandonment of Inactive Water System	LS	1	\$10,000.00	\$10,000.00	\$30,350.00	\$30,350.00	\$5,800.00	\$5,800.00		
10A	Disposal of Asbestos Cement Water Main	LF	50	\$250.00	\$12,500.00	\$250.00	\$12,500.00	\$135.00	\$6,750.00		
11A	6-inch Gate Valve	EA	2	\$3,500.00	\$7,000.00	\$1,572.50	\$3,145.00	\$2,500.00	\$5,000.00		
12A	12-inch Gate Valve	EA	6	\$5,000.00	\$30,000.00	\$3,872.50	\$23,235.00	\$5,500.00	\$33,000.00		
13A	Fire Hydrant Assembly	EA	3	\$12,000.00	\$36,000.00	\$10,834.00	\$32,502.00	\$10,500.00	\$31,500.00		
14A	Connection to Existing System	EA	5	\$10,000.00	\$50,000.00	\$10,920.00	\$54,600.00	\$6,500.00	\$32,500.00		
15A	Demolition	LS	1	\$10,000.00	\$10,000.00	\$10,000.00	\$10,000.00	\$1,200.00	\$1,200.00		
16A	Hot Mix Asphalt (HMA)	TN	40	\$200.00	\$8,000.00	\$400.00	\$16,000.00	\$425.00	\$17,000.00		
17A	Crushed Rock	TN	1,000	\$45.00	\$45,000.00	\$25.00	\$25,000.00	\$48.00	\$48,000.00		
18A	Site Restoration	FA	1	\$10,000.00	\$10,000.00	\$10,000.00	\$10,000.00	\$10,000.00	\$10,000.00		
19A	Traffic Control Plan and Temporary Roadway	LS	1	\$22,500.00	\$22,500.00	\$61,016.00	\$61,016.00	\$104,000.00	\$104,000.00		
20A	Minor Change	FA	1	\$20,000.00	\$20,000.00	\$20,000.00	\$20,000.00	\$20,000.00	\$20,000.00		
<b>Schedule A Subtotal =</b>					<b>\$391,050.00</b>	<b>Sch. A Subtotal</b>		<b>\$492,224.70</b>	<b>Sch. A Subtotal</b>		<b>\$497,816.00</b>
<b>9.6% Sales tax =</b>					<b>\$37,540.80</b>	<b>Tax</b>		<b>\$47,253.57</b>	<b>Tax</b>		<b>\$47,790.34</b>
<b>Total Schedule A =</b>					<b>\$428,590.80</b>	<b>Sch. A Total</b>		<b>\$539,478.27</b>	<b>Sch. A Total</b>		<b>\$545,606.34</b>

## Bid Tabulation

<b>Project Name:</b>		Valley Ave Water System Improvements							
<b>CIP No.:</b>		25-05							
<b>Bid Opening Date:</b>		April 14, 2026							
<b>Notes:</b>		<b>Engineer's Estimate</b>				<b>Bidder #1</b>		<b>Bidder #2</b>	
Indicates error corrected by PW dept		\$X,XXX.XX				HCON Inc.		NW Cascade, Inc.	
Indicates Bidder modified Proposal		\$X,XXX.XX				P.O. Box 731005		P.O. Box 73399	
Indicates Revision Due to Duplication		*				Puyallup, WA 98373		Puyallup, WA 98373	
		<b>Total Bid</b>				<b>\$620,240.80</b>		<b>Total Bid</b>	
						<b>\$690,932.87</b>		<b>Total Bid</b>	
								<b>\$877,663.34</b>	
Bid Item	Bid Item Description	Unit	Quant	Unit Price	Amount	Unit Price	Amount	Unit Price	Amount
<b>Bid Schedule B - Roadway Improvements</b>									
1B	Mobilization, Demobilization, Site Preparation, and Cleanup	LS	1	\$14,000.00	\$14,000.00	\$3,000.00	\$3,000.00	\$35,405.00	\$35,405.00
2B	Construction Survey and As-Built Record Drawings	LS	1	\$3,400.00	\$3,400.00	\$1,000.00	\$1,000.00	\$2,000.00	\$2,000.00
3B	Temporary Sedimentation and Erosion Control	LS	1	\$3,400.00	\$3,400.00	\$500.00	\$500.00	\$7,600.00	\$7,600.00
4B	Demolition	LS	1	\$6,000.00	\$6,000.00	\$6,400.00	\$6,400.00	\$22,000.00	\$22,000.00
5B	Perpendicular Curb Ramp (Type A)	EA	2	\$5,000.00	\$10,000.00	\$3,986.50	\$7,973.00	\$4,745.00	\$9,490.00
6B	Hot Mix Asphalt (HMA)	TN	50	\$200.00	\$10,000.00	\$500.00	\$25,000.00	\$395.00	\$19,750.00
7B	Cement Concrete Sidewalk	SY	150	\$150.00	\$22,500.00	\$104.16	\$15,624.00	\$79.00	\$11,850.00
8B	Cement Concrete Traffic Curb and Gutter	LF	130	\$75.00	\$9,750.00	\$60.52	\$7,867.60	\$63.00	\$8,190.00
9B	Thermo-plastic Traffic Markings	LS	1	\$5,000.00	\$5,000.00	\$4,290.00	\$4,290.00	\$4,000.00	\$4,000.00
10B	Crushed Rock	TN	270	\$45.00	\$12,150.00	\$25.00	\$6,750.00	\$77.00	\$20,790.00
11B	Roadway Site Restoration	FA	1	\$10,000.00	\$10,000.00	\$10,000.00	\$10,000.00	\$10,000.00	\$10,000.00
12B	Traffic Control Plan and Temporary Roadway Closures	LS	1	\$22,500.00	\$22,500.00	\$14,000.00	\$14,000.00	\$50,000.00	\$50,000.00
13B	Minor Change	FA	1	\$20,000.00	\$20,000.00	\$20,000.00	\$20,000.00	\$20,000.00	\$20,000.00
		<b>Schedule B Total</b>				<b>\$148,700.00</b>		<b>Sch. B Total</b>	
						<b>\$122,404.60</b>		<b>Sch. B Total</b>	
								<b>\$221,075.00</b>	
<b>Bid Schedule C - Stormwater Improvements</b>									
1C	Mobilization, Demobilization, Site Preparation, and Cleanup	LS	1	\$4,000.00	\$4,000.00	\$1,000.00	\$1,000.00	\$15,250.00	\$15,250.00
2C	Construction Survey and As-Built Record Drawings	LS	1	\$3,400.00	\$3,400.00	\$1,000.00	\$1,000.00	\$1,740.00	\$1,740.00
3C	Temporary Sedimentation and Erosion Control	LS	1	\$3,400.00	\$3,400.00	\$500.00	\$500.00	\$7,025.00	\$7,025.00
4C	Potholing Existing Utilities	EA	2	\$1,000.00	\$2,000.00	\$500.00	\$1,000.00	\$596.00	\$1,192.00
5C	Shoring and Trench Safety Systems	LS	1	\$1,000.00	\$1,000.00	\$500.00	\$500.00	\$1,515.00	\$1,515.00
6C	12-Inch Stormwater Pipe	LF	55	\$200.00	\$11,000.00	\$200.00	\$11,000.00	\$100.00	\$5,500.00
7C	Demolition	LS	1	\$4,000.00	\$4,000.00	\$1,500.00	\$1,500.00	\$27,500.00	\$27,500.00
8C	Hot Mix Asphalt (HMA)	TN	5	\$200.00	\$1,000.00	\$300.00	\$1,500.00	\$503.00	\$2,515.00
9C	Crushed Rock	TN	70	\$45.00	\$3,150.00	\$25.00	\$1,750.00	\$52.00	\$3,640.00
10C	Traffic Control Plan and Temporary Roadway Closures	LS	1	\$5,000.00	\$5,000.00	\$4,300.00	\$4,300.00	\$40,105.00	\$40,105.00
11C	Minor Change	FA	1	\$5,000.00	\$5,000.00	\$5,000.00	\$5,000.00	\$5,000.00	\$5,000.00
		<b>Schedule C Total</b>				<b>\$42,950.00</b>		<b>Sch. C Total</b>	
						<b>\$29,050.00</b>		<b>Sch. C Total</b>	
								<b>\$110,982.00</b>	
		<b>Total Schedule A+ B+C =</b>				<b>\$620,240.80</b>		<b>Total Schedule A+ B+C =</b>	
						<b>\$690,932.87</b>		<b>Total Schedule A+ B+C =</b>	
								<b>\$877,663.34</b>	
		Prepared by: Andrew Leach							
		Date: 4/14/2026							

---

**SUBJECT:** Resolution No. 1749 - WSDOT Updated Right-of-Way Procedures

**CATEGORY:** Consent

---

**BUDGET IMPACT:**

Expenditure Required: None

Within Budget Allocation: N/A

---

**ATTACHMENTS:**

1. Resolution No. 1749 - WSDOT Updated Right-of-Way Procedures

**STAFF CONTACT:** Michael Kosa, Public Works Director

---

**SUMMARY BACKGROUND:**

The City maintains official Right-of-Way Procedures for the acquisition of real property, as needed. This is also a required document when utilizing federal funds to acquire real property.

Periodically, these procedures need to be updated due to staff changes and any revisions to the documents required or requested by WSDOT or other applicable laws. This update makes changes to match current staff and their titles, and only minor substantive revisions to the procedures were required.

---

<p><b>COUNCIL COMMITTEE/STUDY SESSION:</b> Public Works Committee <b>MEETING/STUDY SESSION DATE:</b> 4/21/2026 <b>COMMITTEE RECOMMENDATION:</b> Do Pass</p>
---

**STAFF RECOMMENDATIONS/MOTION:**

A motion to adopt Resolution No. 1749 - Updating the WSDOT Right-of-Way Procedures for the Acquisition of Real Property in Accordance with State and Federal Regulations.

**RESOLUTION NO. 1749  
CITY OF SUMNER, WASHINGTON**

**A RESOLUTION OF THE CITY COUNCIL OF THE CITY OF SUMNER, WASHINGTON, UPDATING RIGHT-OF-WAY PROCEDURES FOR THE ACQUISITION OF REAL PROPERTY IN ACCORDANCE WITH STATE AND FEDERAL REGULATIONS.**

**WHEREAS**, the City receives Federal and State funding for the acquisition of property relative to various public works projects; and

**WHEREAS**, pursuant to prior Resolutions the City formally adopted procedures consistent with the Washington State Department of Transportation (WSDOT) and the Federal Highway Administration (FHWA) rules and regulation relative to the use and expenditure of funding and property acquisition; and

**WHEREAS**, the City of Sumner desires to reaffirm and update the existing policies and procedures.

**NOW, THEREFORE, THE CITY COUNCIL OF THE CITY OF SUMNER, WASHINGTON DOES RESOLVE AS FOLLOWS:**

**Section 1.** The Mayor is hereby authorized and directed to execute the attached Right-of-Way procedures attached hereto as Exhibit “A”.

**Section 2. Corrections by City Clerk or Code Reviser.** Upon approval of the city attorney, the city clerk and the code reviser are authorized to make necessary corrections to this resolution, including but not limited to the correction of clerical errors; or references to other local, state, or federal laws, codes, rules, or regulations.

**Section 3.** The Mayor is hereby authorized to implement such administrative procedures as may be necessary to carry out the directions of this legislation

**Section 4. Effective Date.** This resolution shall take effect and be in force immediately upon passage by City Council.

**ADOPTED AND APPROVED** this \_\_\_\_\_ day of \_\_\_\_\_, 2026.

\_\_\_\_\_  
Mayor Carla S. Bowman

**ATTEST:**

**APPROVED AS TO FORM:**

\_\_\_\_\_  
Michelle Converse, CMC, City Clerk

\_\_\_\_\_  
City Attorney Andrea Marquez

# *Right of Way Procedures*

---

The City of Sumner (Agency), needing to acquire real property (obtain an interest in and/or possession of) in accordance with the Uniform Relocation Assistance and Real Property Acquisition Policies Act and applicable federal regulations (49 CFR Part 24) and state law (Ch. 8.26 RCW), and state regulations (Ch. 468-100 WAC) hereby adopts the following procedures to adhere to all applicable laws, statutes, and regulations. The Agency is responsible for the real property acquisition and relocation activities on projects administered by the Agency and must acquire right of way (ROW) in accordance with the policies outlined in the Washington State Department of Transportation Right of Way Manual M 26-01 and Local Agency Guidelines (LAG) Manual.

1. Below is a list of Agency staff, by name and position titles, who are qualified to perform specific ROW functions. Attached to these procedures are resumes for everyone listed within these procedures, which provide a summary of their qualifications. The procedures shall be updated whenever staffing changes occur.
  - a. The Agency has the staff with the knowledge and experience to accomplish the following ROW Disciplines:
    - i. **PROGRAM ADMINISTRATION:**  
Oversee the delivery of the ROW Program on federal aid projects for the Agency. Ensures ROW functions are conducted in compliance with federal and state laws, regulations, policies, and procedures.

**Responsibilities/Expectations:**

- Ensures the Agency’s approved ROW Procedures are current, including staff qualifications, and provides copies to consultants and Agency staff;
- Oversight of ROW consultants;
  - Ensure that the hired consultants meet the minimum requirements outlined in ROW Manual Chapters 2 & 8 and Chapter 3 for Appraisal and Appraisal Review.
  - Use of consultant contract approved by WSDOT
  - Management of ROW contracts
  - Management of ROW files
  - Reviews and approves actions and decisions recommended by staff & consultants
  - Overall responsibility for decisions that are outside the purview of consultant functions
- Sets Just Compensation before offers are made;
- Oversight and approval of Waiver Valuations per policy;
- Oversight and approval of Administrative Settlements per policy;
  - Ensure that Administrative Settlements are reviewed and accepted by the Local Agency Coordinator prior to final signature.
- Ensure the Agency has a relocation appeal process before starting relocation activities;
- Obligation authority for their Agency;
- Obtain permits (Non-Uniform Relocation Act (URA));
- Ensures there is a separation of functions to avoid conflicts of interest.

- Verifies whether ROW is needed and that the property rights and/or interests needed are sufficient to construct, operate, and maintain the proposed projects. See LAG Appendix 25.171, 25.1726, and the No ROW Checklist (LPA-008).

Michael Kosa – Public Works Director, Andrea Marquez – City Attorney, Alisa O’Haver-Ayala – Deputy Public Works Director, Andrew Leach – Senior Associate City Engineer, Courtney Littrell – Assistant Engineering Manager

---

Note: Staff included under Program Administration must have completed the eLearning Administrative Settlement and No ROW Verification training available at <https://wsdot.wa.gov/business-wsdot/support-local-programs/local-programs-training/right-way-training-education>

ii. APPRAISAL

Prepare and deliver appraisals on federal aid projects for the Agency. Ensures that appraisals are consistent and in compliance with state and federal laws, regulations, policies, and procedures.

**Responsibilities/Expectations:**

- Use only qualified agency staff or consultants who meet the requirements outlined in ROW Manual Chapter 3 to perform appraisal work;
- Prepare ROW Funding Estimate (not required to be completed by an appraiser & only when there are federal funds in the ROW Phase);
- Prepare Waiver Valuation;
- Obtain specialist reports;
- Coordinate with engineering, program administration, acquisition, relocation, and/or property management.

CONTRACT WITH A QUALIFIED CONSULTANT

---

iii. APPRAISAL REVIEW:

Review appraisals on federal aid projects for the Agency to ensure they are adequate and reliable, have reasonable supporting data, and approve appraisal reports. Ensure appraisals are adequately supported, represent fair market value and applicable costs to cure, and are completed in compliance with state and federal laws, regulations, policies, and procedures.

**Responsibilities/Expectations:**

- Use only qualified agency staff or consultants that meet the requirements outlined in ROW Manual Chapter 3 to perform appraisal review work;
- Ensures project-wide consistency in approaches to value, use of market data, and costs to cure;
- Coordinate with engineering, program administration, acquisition, relocation, and/or property management.

CONTRACT WITH A QUALIFIED CONSULTANT

---

iv. **ACQUISITION:**

Acquire, through negotiation with property owners, real property or real property interests (rights) on federal aid projects for the Agency. Ensures acquisitions are completed in compliance with federal and state laws, regulations, policies, and procedures.

**Responsibilities/Expectations:**

- Use only qualified staff/consultants to perform acquisition activities for real property or real property interests, including donations;
- Staff and consultants must meet the requirements outlined in ROW Manual Chapters 2 & 8
- To avoid a conflict of interest, when the acquisition function prepares a Waiver Valuation, only acquires property valued at \$15,000 or less;
- Provide and maintain a comprehensive written account of acquisition activities for each parcel;
- Prepare Waiver Valuation justification and obtain approval;
- Prepare Administrative Settlement and obtain approvals;
- Prepare Right of Way Funding Estimate (when there are federal funds in the ROW Phase);
- Review title, and recommend and obtain approval for acceptance of encumbrances;
- Ensure acquisition documents are consistent with ROW plans, valuation, and title reports;
- Provide a negotiator disclaimer;
- Maintain a complete, well-organized parcel file for each acquisition;
- Coordinate with engineering, program administration, appraisal, relocation, and/or property management.

**CONTRACT WITH A QUALIFIED CONSULTANT**

---

Note: Staff included under Acquisition must have completed the eLearning Administrative Settlement training available at <https://wsdot.wa.gov/business-wsdot/support-local-programs/local-programs-training/right-way-training-education>

v. **RELOCATION:**

Provide relocation assistance to occupants of property considered displaced by federally funded projects for the Agency. Ensures relocations are completed in compliance with federal and state laws, regulations, policies, and procedures.

**Responsibilities/Expectations:**

- Only qualified staff/consultants are used to perform relocations that meet the requirements outlined in ROW Manual Chapters 2 & 8.
- Prepare and obtain approval of relocation plan before starting relocation activities;
- Confirm relocation appeal procedure is in place;
- Provide required notices and advisory services;

- Make calculations and provide recommendations for the Agency approving authority before making payment;
- Provide and maintain a comprehensive written account of relocation activities for each parcel;
- Maintain a complete, well-organized parcel file for each displacement;
- Ensure occupants and personal property are removed from the ROW;
- Coordinate with engineering, program administration, appraisal, acquisition, and/or property management.

## CONTRACT WITH A QUALIFIED CONSULTANT

---

### vi. PROPERTY MANAGEMENT:

Establish property management policies and procedures that will assure the control and administration of ROW, excess lands, and improvements acquired on federal aid projects for the Agency. Ensure that property management activities are completed in compliance with federal and state laws, regulations, policies, and procedures.

#### **Responsibilities/Expectations:**

- Only qualified staff/consultants are used to perform property management that meets the requirements outlined in ROW Manual Chapters 2 & 8.
- Account for use of proceeds from the sale/lease of property acquired with federal funds on other Title 23 eligible activities;
- Keep ROW free of encroachments;
- Obtain WSDOT/FHWA approval for a change in access control along the interstate;
- Maintain property records;
- Ensure occupants and personal property are removed from the ROW;
- Maintain a complete, well-organized property management file;
- Coordinate with engineering, program administration, appraisal, acquisition, and/or property management.

Michael Kosa – Public Works Director, Andrea Marquez – City Attorney, Alisa O’Haver-Ayala – Deputy Public Works Director

---

- b. Any functions for which the Agency does not have qualified staff, the Agency will contract with another local agency with approved procedures, a qualified consultant, or the WSDOT. An Agency that proposes to use qualified consultants for any of the above functions must work closely with its Local Agency Coordinator (LAC) and Local Programs to ensure all requirements are met. The LAC will perform spot-check reviews on selected federal aid or federal aid-eligible projects. **The LAC must be given an opportunity to review all offers and supporting data before offers are made to the property owners.** The number of spot-check reviews depends on the project scope, the complexity of acquisitions, the local agency’s level of experience, and past performance. Spot check reviews may not be required on all projects, but will lessen the risk of delays during ROW Certification. The LAC may request additional information or parcel files to ensure local agency compliance.

- c. The Agency’s Administrative Settlement Procedures, indicating the approval authorities and the procedures involved in making administrative settlements, need to be included with these procedures (see Exhibit A).
  - d. An Agency wishing to take advantage of the Waiver Valuation process for properties valued up to \$35,000 or less must complete Exhibit B of these procedures.
2. All projects shall be available for review by the FHWA and Local Programs ROW at any time, and all project documents shall be retained and available for inspection during the plan development, ROW, and construction stages and for three years following Local Programs' acceptance of the projects.
  3. Local Programs ROW may rescind its approval of the agency's procedures at any time the Agency is found to no longer have qualified staff or is found to be in non-compliance with the regulations. The rescission may apply to all or part of the approved functions.
  4. The Agency must review these procedures every three years to verify that they are current. Procedures need to be updated for one or more of the following reasons:
    - a. Staff Changes
    - b. If the Agency is considering early acquisition for an unfunded project, the Agency must have current procedures.
    - c. A change is requested regarding staff who can perform specified activities.
    - d. Revisions to the ROW Program, such as statutory, regulatory, or policy changes.

---

Carla S. Bowman, Mayor

---

Date

**Washington State Department of Transportation**

Approved By:

---

Local Programs Right of Way Manager

# **EXHIBIT A**

## **Agency's Administrative Settlement Policy**

### **SECTION I. ADMINISTRATIVE SETTLEMENT POLICY.**

The CITY shall make every reasonable effort to expeditiously acquire real property by negotiation. Negotiation implies an honest effort by the CITY to resolve differences with property owners. Offers can be flexible and negotiations should recognize the inexact nature of the process by which just compensation is determined. The CITY shall endeavor to expedite the acquisition of real property by agreements with owners and to avoid litigation and relieve congestion in the courts.

- A. In conjunction with and after review by the City Attorney, the CITY shall carefully consider and maximize the use of administrative settlements in appropriate situations. An administrative settlement or stipulated settlement is a negotiated settlement of a right-of-way acquisition case in which the CITY has administratively approved payment in excess of fair market value as shown on the CITY's approved determination of value (review appraiser's certificate) that takes into account other relevant and appropriate factors that would increase settlement costs such as litigation costs and other factors described in Section B below.
- B. In conjunction with and after review by the City Attorney, administrative settlements may be approved when it is determined that such action is in the public interest. In arriving at a determination to approve an administrative settlement, the following non-exclusive factors may be considered:
  - 1. All available appraisals, including the owner's comparable sales not included in an appraisal, and the probably range of testimony in the condemnation trial.
  - 2. Ability of the City to acquire the property, or possession, through the condemnation process to meet the construction schedule.
  - 3. Impact of construction delay pending acquisition.
  - 4. The negotiator's recorded information, including parcel details and the owner's rationale for increased compensation.
  - 5. Recent court awards in cases involving similar acquisition and appraisal problems.
  - 6. Likelihood of obtaining an impartial jury in local jurisdiction, and the opinion of legal counsel where appropriate.
  - 7. Estimate of trial cost weighed against other factors.

### **SECTION II. AUTHORITY**

- A. The Public Works Director or City Engineer shall have authority to waive appraisals on properties valued at \$25,000 or less. In conjunction with and after review by the City Attorney, the Public Works Director or City Engineer shall have the authority to sign CITY concurrence with the waiver evaluation as Just Compensation and authorize the commencement of negotiations.

- B. In conjunction with and after review by the City Attorney, the Public Works Director or City Engineer shall have authority to sign CITY concurrence with the Appraisal Review (Determination of Value) as Just Compensation and authorize the commencement of negotiations.
- C. In conjunction with and after review by the City Attorney, the Public Works Director or City Engineer has the authority to approve all Administrative settlements. The Voucher for payment and the acquisition documents will be approved by the City Council prior to payment unless after review by the City Attorney, the Public Works Director or City Engineer may have the acquisition documents ratified and confirmed by the City Council.

### SECTION III. RELOCATION COMPENSATION APPEAL PROCEDURES

Owners and tenants who are eligible for expenses related to relocation may appeal the determined compensation amount. The City shall promptly review appeals with the procedure set forth below:

- A. Actions which may be appealed. Any aggrieved person may file a written appeal to the City's Public Works Director in any case in which the person believes that the City has failed to properly consider the person's application for relocation assistance as required by Federal Highway Administration related project. Such assistance may include, but is not limited to, the person's eligibility for, or the amount of, a payment required under 49 CFR §24.106 or 49 CFR §24.107, or a relocation payment as required by law. The City shall consider a written appeal regardless of form.
- B. Time limit for initiating appeal. An aggrieved person shall file an appeal with the Public Works Director no later than 60 calendar days after the person receives written notification of the City's determination on the person's claim.
- C. Right to representation. A person has a right to be represented by legal counsel or other representative in connection with his or her appeal, but solely at the person's own expense.
- D. Review of files by person making appeal. The City shall permit a person to inspect and copy all materials pertinent to his or her appeal, except materials which are classified as confidential by the City. The City may, however, impose reasonable conditions on the person's right to inspect, consistent with applicable laws.
- E. Scope of review of appeal. In deciding an appeal, the City shall consider all pertinent justification and other material submitted by the person, and all other available information that is needed to ensure fair and full review of the appeal.
- F. Determination and notification after appeal. Promptly after receipt of all information submitted by a person in support of an appeal, the City shall make a written determination on the appeal, including an explanation of the basis on which the decision was made, and furnish the person a copy. If the full relief requested is not granted, the City shall advise the person of his or her right to seek judicial review of the City decision.
- G. City official to review appeal. The City's duly appointed Hearing Examiner shall hear the appeal no later than thirty (30) calendar days from the date the appeal was filed

---

Carla S. Bowman, Mayor

---

Date

**Washington State Department of Transportation**

Approved By:

---

Local Programs Right of Way Manager

**EXHIBIT B**  
**Agency's Waiver Valuation**

The City of Sumner , hereinafter (Agency), desiring to acquire Real Property according to 23 CFR, Part 635, Subpart C, 49 CFR Part 24, and State directives, and desiring to take advantage of the waiver valuation process approved by the Federal Highway Administration (FHWA) for Washington State, hereby agrees to follow the procedure approved for the Washington State Department of Transportation (WSDOT) as follows:

Rules

- A. The Agency may elect to waive the requirement for an appraisal if the acquisition is simple, has a low fair market value, and the compensation estimate (including the cost to cure items) and the estimated property value are under \$35,000.
- B. The Agency must make the property owner(s) aware that an appraisal has not been completed on the property for offers of \$15,000 or less.
- C. The Agency must inform the property owner(s) that an appraisal has not been completed on the property for offers over \$15,001 and up to \$35,000, and that an appraisal will be prepared if requested by the property owner(s).
- D. Special care should be taken in preparing the Waiver Valuation, as no review is mandated, the preparer needs to ensure that the compensation is fair and that all the calculations are correct.

Procedures

- A. A Waiver Valuation is prepared using comparable sales found and verified during preparation.
- B. The Waiver Valuation is approved by the Agency staff listed under Program Administration within these Right of Way Procedures. Once the local agency coordinator has completed a spot check for the project, an offer to the property owner(s) is authorized upon signature.

---

Carla S. Bowman, Mayor

---

Date

**Washington State Department of Transportation**

Approved By:

---

Local Programs Right of Way Manager

# Michael R. Kosa, P.E.

[michaelk@sumnerwa.gov](mailto:michaelk@sumnerwa.gov) 253-299-5709  
1104 Maple St, Sumner, WA 98390

## WORK EXPERIENCE

PUBLIC WORKS DIRECTOR (2023-PRESENT), CITY ENGINEER (2021-2023), SUMNER, WA  
ASSOCIATE CITY ENGINEER (2017-2021) 2017-PRESENT  
CITY OF SUMNER

As the public works director at the City of Sumner, I am responsible for managing the City's capital improvement efforts and the City's wastewater treatment facility. I am one of five licensed civil engineers on staff.

- Manage Public Works staff as needed to complete projects.
- Manage transportation projects in various stages of design and construction, including in-house and consultant-led designs, project tracking and scheduling. Currently managing projects with a total construction value of \$50 million.
- Manage stormwater capital improvement and maintenance projects as well as the city's compliance with the City's Phase II MS4 Permit.
- Interact with the public regarding traffic and roadway concerns.
- Represent the Public Works department and present projects and agenda bills at public meetings, City Council meetings and through media outlets. Represent the City at regional forums such as PSRC and Pierce Co. Transportation Coordinating Committee. Interact with WSDOT Local Programs on a regular basis.
- Juggle competing needs of projects, meetings, and day-to-day engineering challenges.
- **Manage projects with right-of-way needs as an authorized Program Administration and Property Management agency staff member.**

CIVIL ENGINEER PAPIILLION, NE  
SARPY COUNTY PUBLIC WORKS 2014-2017

As a civil engineer at Sarpy County Public Works, I provided recommendations and solutions to challenges that arise while managing transportation and drainage-related projects. I was one of three licensed civil engineers on staff.

- Managed projects in various stages of design and construction. Managed staff as needed to complete project and regulatory related work.
- Took initiative when needed such as compiling necessary regulatory reports to comply with Americans with Disabilities Act state requirements.
- Oversaw contractors, vendors, and professional firms holding them accountable regarding roadway improvement related contracts.
- Founded and led the standards committee, which works to streamline work processes within the Public Works department.
- Completed county-wide private plans review for public infrastructure.
- Sealed \$1-2M worth of County projects annually as the Engineer of Record.
- **Directed design consultants preparing right-of-way plans.**
- **Managed multiple projects needing right-of-way negotiations and purchases involving property owners, utilities, and local governments within the County.**

CIVIL ENGINEER/PROJECT MANAGER US AIR FORCE ACADEMY, CO  
CH2M HILL ACADEMY SERVICES (joint venture now dissolved) 2013-2014

As a civil engineer at the US Air Force Academy, I managed a number of ongoing design and construction projects. I managed the roadway pavement replacement program on base and was the lead technical engineer for drainage, erosion control, and traffic-related issues.

- Managed seven projects awarded and constructed in fiscal year 2014.
- Reviewed consultant plans to ensure plans meet local, federal, and military standards.

- Represented the US Air Force Academy in inter-agency meetings with city, county, and state officials on transportation and drainage related topics.

WATER RESOURCES ENGINEER COLORADO SPRINGS, CO  
 AECOM (formerly URS Corporation) 2012-2013

As a water resources engineer, the majority of my focus was hydrology and hydraulic structure design. I designed transportation drainage systems including culverts, storm drain systems, water quality facilities, and erosion control measures.

- Managed four staff members as the Colorado Springs Water Resources Design Lead. Oversaw daily workload and subordinate evaluations.
- Drainage design engineer of record for two projects for the City of Colorado Springs and two projects for El Paso County.

CIVIL ENGINEER SPOKANE/BELLEVUE, WA  
 DAVID EVANS AND ASSOCIATES, INC. 2007-2012

As a transportation engineering design consultant, the focus of my position was roadway drainage design. I interacted with the other disciplines such as roadway engineers to coordinate drainage needs with roadway plan and profile design.

- Managed team of three to six designers during labor-intensive design submittals.
- Project engineer on WSDOT SR-520 Design-Build project in Seattle, specializing in structure and local road drainage design.
- Led drainage design for 80-turbine design-build wind farm project in California.
- **Met with 20 property owners on US 95 Expansion in Athol, ID regarding upcoming property negotiations. Represented project at public meeting as a design representative.**

DESIGN ENGINEER 2, PROJECT MANAGER SEATTLE, WA  
 MAGNUSSON KLEMENCIC ASSOCIATES 2004-2007

I participated in general Land Development civil engineering, including sidewalk and urban infill design. I coordinated design elements with architects, owner representatives, regulatory agencies, and other consultants.

- Developed projects from early schematic design through construction administration.
- Produced a variety of deliverables including drainage reports, early concept-level sketches, design drawing sets, calculations, and sketches during construction.

## EDUCATION

B.S. CIVIL ENGINEERING WITH A SPECIALIZATION SEATTLE, WA  
 IN ENVIRONMENTAL ENGINEERING JUNE 2004  
 MINOR IN MATHEMATICS Seattle University GPA: 3.90

- Graduated magna cum laude, member of the Dean's List all quarters.

## COURSEWORK, TECHNOLOGY, AND TRAINING

- Proficient use of Microstation, AutoCAD, and Microsoft Office
- Supervisor Training through the Washington Cities Insurance Authority (2017)
- 30+ hours of Project Management training (2015)
- Attended 2015 and 2016 APWA national conference
- **No Right of Way (ROW) Verification Training: Completed July 2017**
- **NHI Course FHWA-NHI-141045: Completed 12/29/2017**
- **NHI Course FHWA-NHI-141047: Completed 7/2/2018**
- **WSDOT Administrative Settlement Documentation Course Completion 5/12/2022**
- Federal Grants Requirements and Management (WFOA): Completed 11/14/2017
- Attended various training classes through regarding drainage and clear zone design

## PROFESSIONAL REGISTRATIONS

- Civil Engineer: Washington State (Lapsed: Nebraska, Colorado, Idaho)
- Member, American Public Works Association, Washington Chapter

# Andrea J. Marquez

1104 Maple St, Sumner, WA 98390  
Andream@sumnerwa.gov  
(253) 260-2427

## PROFESSIONAL MEMBERSHIPS

- Washington State Bar Association, 2012-present, WSBA #45670
- Active member of the Pierce County Bar Association
- Certified Professional Mediator
- Active member of the Washington State Association of Municipal Attorneys
- WCMA Women's Leadership Graduate
- Past President-Elect, Young Lawyer's Association
- Pierce County Young Professional's Network, 2013-present

## PROFESSIONAL EXPERIENCE

**City Attorney:** May 2017-present

**Deputy City Attorney:** July 2016-May 2017

**Practice Areas:** Land Use, Real Estate Acquisitions/Dispositions, Condemnation, Human Resources, Criminal Prosecution, Public Contracting/Bidding, Labor Union; Legal Advisor to Mayor, City Council, Police Department, and City departments.

- Develop annual budget for Legal Department, monitor and control budget expenditures;
- Supervise and coordinate the acquisition and dispositions of real property, including working with property owners, funding agencies, escrow companies, right of way consultants, and City staff.
- Negotiate real property leases, easements, and acquisitions for City projects. Work with right of way consultants on acquisitions in accordance with the Federal guidelines, including relocations.
  - Representative Projects involving Federal/State Funding Property Acquisitions:
    - Bridge St. Bridge Replacement Project – total and partial acquisitions from four separate property owners. Assisted in the drafting and processing of Possession and Use Agreements, Condemnation Pleadings and court hearings, through to Decree of Appropriation.
    - White River Trail Pedestrian Bridge Project – worked with right of way consultant on the negotiation of property acquisition for a new pedestrian bridge funded with federal grant funds. Negotiations reached an impasse and the City determined not to file for condemnation, thereby foregoing the project.
    - 410/Traffic Avenue Replacement Project – federally funded highway improvement project requiring temporary easement rights from neighboring jurisdictions.
    - Pedestrian Sidewalk Improvements – sidewalk improvement projects requiring a conveyance of public right of way.
    - White River Restoration Project – largest river restoration project in the Puget Sound region, requiring the acquisition of 20+ parcels (either partial or full) for a flood mitigation, river restoration, and habitat management project. Work with right of way consultant through the federal acquisition and relocation process for each identified parcel, where applicable.
    - City park expansions – negotiate and prepare all transactional documents related to the acquisition of two parcels necessary for expansion of the City's park system. The acquisitions were locally funded, but the park projects are anticipated to be partially funded by state grants.

**Associate Litigation Attorney, *Oldfield & Helsdon, PLLC***

June 2013-July 2016

**Practice Areas:** High-volume litigation and transactional firm focusing on business, real estate, land use, commercial, municipal law, bankruptcy, estate planning and probate, and appellate litigation; Provide excellent and thorough legal representation, and consulting services to a broad range of individual and business clients.

- Experience litigating and negotiating complex real estate, land use, business, and commercial disputes and contracts. Consistently employ dispute resolution techniques and strategies to improve efficiency and facilitate solutions.
- Actively involved in the trial strategy and problem-solving processes; Quick thinker in high-stress and fast-paced environments relying on my strong, punctual, and friendly interpersonal communication skills;
- Demonstrated ability to meet demanding deadlines;
- Excellent analytical skills; keen ability to consider and comprehend complex information and create appropriate and compliant responses;
- Fast and thorough legal researcher; Experience drafting legal pleadings for all stages of litigation or municipal/land use petitions.
- Strong client-facing presence; natural and confident leader in both individual and group settings;

**Associate Attorney, *Law Office of Catherine C. Clark, PLLC*** August, 2012-June, 2013

**Practice Areas:** Trial & Appellate Practice (Real estate, eminent domain/condemnation, land use, municipal law; commercial litigation; significant personal injury).

- Second chair in two large and contested eminent domain/condemnation trials;
- Performed extensive legal research and writing; Experience drafting memorandums, complaints, answers, demand letters, motions for summary judgment, motions to dismiss, interrogatories, requests for production, motions in limine, default motions/orders, settlement agreements, and client or attorney correspondence.
- Provided guidance, counsel and support to senior counsel and clientele on all real estate and condemnation matters.

**EDUCATION*****University of Oregon School of Law***, Eugene, OR**Juris Doctorate**, 2012 • Curriculum Focus: Business Law,

- Law Review Executive Editor, Oregon Review of International Law, 2010-2012.
- First place: 2010 Regional Mediation Competition
- Small Business Clinic Associate: provided individualized business representation to local small businesses, including entity creation, strategic business advice, and transactional documents.
- BARBRI Head Representative
- CEO, Sports and Entertainment Law Forum

***University of Washington*****Dual Bachelor of Arts**, Political Science and Economics, 2009

- All-American Student-Athlete, Women's Track and Field – Polevault; Four Year Varsity Letter Winner
- PAC-10 Academic Honors
- Dean's List, 2007-2009

# Alisa O'Haver-Ayala, PE, CCM

DEPUTY PUBLIC WORKS DIRECTOR | CITY ENGINEER

1104 Maple Street, Suite 260 Sumner, WA 98390 / 253-299-5703 / ALISAO@SUMNERWA.GOV

## WORK EXPERIENCE

**DEPUTY PUBLIC WORKS DIRECTOR, CITY OF SUMNER; SUMNER, WA** 2024-PRESENT  
**ASSOCIATE CITY ENGINEER, CITY OF SUMNER; SUMNER, WA** 2022-2024

- Providing technical engineering expertise to Engineering staff.
- Assuming responsibility for assigned services and activities of assigned responsibilities which includes public works projects, capital project support and management, utilities systems management and administrative support programs and services.
- Conducting a variety of organizational studies; recommending modifications to assigned programs, policies, and procedures as appropriate.
- Assisting the Public Works Director in coordinating the activities of the division.
- Meeting and working with engineering consultants, contractors, state and federal agency representatives, developers, and the general public.
- Attending public meetings to receive and provide information.
- Grants:
  - Seeking grants for Public Works and other activities, writes grant applications and performing proper follow-up.
  - Managing administrative reporting of CIP grants.
- Administering projects from initiation through project completion, including:
  - Coordinating engineering support and projects performed by other City departments.
  - Directing the preparation and review of public works plans, specifications, and contracts for various construction projects.

**RESIDENT ENGINEER 4, PORT OF SEATTLE; SEATTLE, WA** 2013-2022

- Promoted from Resident Engineer 1 to Resident Engineer 4 over the course of 8 years.
- Working with the design team, contractors, co-workers, and stakeholders to create a collaborative team atmosphere and accomplish the common goal of building a project from concept through closeout.
- Managing multiple construction projects of \$1M - \$10M simultaneously, independently managing construction projects up to \$25M, contributing team member on projects in excess of \$500M
- Supervising three direct reports, mentoring peers and interns
- Providing department leadership by being approachable and providing practical solutions
- Reviewing designs for quality and constructability from concept through bid

- Performing full spectrum of construction management responsibilities including leading project meetings, change management, progress payments, negotiations, RFIs, submittals, schedule review, and reporting.

**OFFICE ENGINEER, URS CORP; SEATTLE, WA** **2011-2013**  
**SDOT SOUTH SPOKANE STREET VIADUCT WIDENING & SOUTH SPOKANE STREET VIADUCT EASTBOUND 4TH AVENUE SOUTH OFF-RAMP; SEATTLE, WA**

- Reviewing contractor's monthly payment request, reviewing inspectors daily note records for unit price bid items, negotiating contractor's monthly payments and logging monthly progress payments for this \$75M unit price contract
- Detailed accounting and reconciliation of over \$3M in force account billings
- Performing additional construction management responsibilities including leading project meetings, change management, and reporting.
- Overseeing the work of those processing RFIs and submittals as well as project file maintenance

**ASSISTANT RESIDENT ENGINEER, HEERY INTERNATIONAL; SEATTLE, WA** **2010-2011**  
**SEATTLE-TACOMA INTERNATIONAL AIRPORT RENTAL CAR FACILITY; SEATTLE, WA**

- Reviewing, negotiating, and processing the monthly progress payments for this \$420M GC/CM project. The average monthly payments were \$11M.
- Performing additional construction management responsibilities including change orders and submittal management.

**PROJECT ENGINEER, KPFF CONSULTING ENGINEERS**  
**SEATTLE, WA** **1998-2000 & 2002-2005**  
**TACOMA, WA** **2005-2009**

- Performing Assistant Project Manager and construction support for design projects
- Civil design for roadways and site development projects for Sound Transit, Multicare Tacoma General Hospital, Port of Seattle's Sea-Tac International Airport, WSDOT, and the City of Seattle.

**TRANSPORTATION ENGR,**  
**KITSAP CTY PUBLIC WORKS; PORT ORCHARD, WA** **2000-2002**

- Civil design for roadway projects and managing consultant roadway designs

**EDUCATION**

Bachelor of Science Civil Engineering (BSCE) - University of Washington; Seattle, WA, 1998

**CERTIFICATIONS**

Professional Engineer, Civil (PE) #39387 - Washington, 2002

Certified Construction Manager (CCM) #4019 - Construction Management Association of America, 2017

**RELEVANT COURSEWORK**

No Right of Way (ROW) Verification Training: Completed 01/25/2022

NHI Course FHWA-NHI-141045: Completed 01/25/2022

Andrew Leach  
1104 Maple St. Suite 260  
Sumner, WA 98390  
Phone: (253) 299-5711  
Email: [andrewl@sumnerwa.gov](mailto:andrewl@sumnerwa.gov)

**Experience:**

January 2023 - Present, Public Works City of Sumner, WA

**Senior Associate City Engineer** - Managed the City's various capital improvement and small works projects. Provided project management and administration assistance for a variety of municipal projects funded by utilities and grants (RCO, WSDOT, & FHWA). Responsibilities included design review, development review, spec writing, grant writing, permit coordination, cost estimation, review/revision of City standards and details, and presenting projects to the Public Works Committee and City Council. Responsible for assisting the City Engineer in planning, organizing, directing, coordinating, and evaluating the work of the Public Works Engineering Division. Supervisor of the Engineering Division.

January 2021 - Present, Public Works City of Sumner, WA

**Public Works Manager** - Managed the City's various capital improvement and small works projects. Provided project management and administration assistance for a variety of municipal projects funded by utilities and grants (RCO, WSDOT, & FHWA). Responsibilities included design review, development review, spec writing, grant writing, permit coordination, cost estimation, review/revision of City standards and details, and presenting projects to the Public Works Committee and City Council. Responsible for assisting the City Engineer in planning, organizing, directing, coordinating, and evaluating the work of the Public Works Engineering Division. Directly supervise two Engineering Technicians and the City's CADD/GIS Technician

December 2017 - January 2021, Public Works City of Sumner, WA

**Associate City Engineer** - Managed the City's various capital improvement and small works projects. Provided project management and administration assistance for a variety of municipal projects funded by utilities and grants (RCO, WSDOT, & FHWA). Responsibilities included design review, development review, spec writing, grant writing, permit coordination, cost estimation, review/revision of City standards and details, and presenting projects to the Public Works Committee and City Council. Responsible for assisting the City Engineer in planning, organizing, directing, coordinating, and evaluating the work of the Public Works Engineering Division.

January 2014- December 2017, Public Works City of Sumner, WA

**Assistant City Engineer** - Assisted with the City's various capital improvement and small works projects. Provided project management and administration assistance for a variety of municipal projects funded by utilities and grants (RCO, WSDOT, & FHWA). Responsibilities included design review, development review, spec writing, grant writing, permit coordination, cost estimation, review/revision of City standards and details, and presenting projects to the Public Works Committee and City Council.

July 2012-December 2013. City of Sumner, WA.

**Engineering Intern - Public Works:** Assisted with the City's various capital improvement projects. Provided project management and administration assistance for a variety of municipal projects funded by utilities and grants (RCO & FHWA). Experienced working with contractor payments and submittals, change orders, and force accounts. Was the project manager and point of contact for a small works project. Duties for the project consisted of creating bid documents, addendums, bid tabs, bid award, submittals, cost estimation, and project budget. Worked with an outside agency, Washington State Department of Transportation (WSDOT), for permitting along SR410. Other Responsibilities included: researching City Standards and details, ADA standards, and transition plans for city implementation. Spearheaded the transition to a new pavement management program for the City of Sumner. Researched new uses and abilities of the cities HOBOWare water monitoring equipment and computer program. Assisted with right of way acquisition documents and mailings. Shadowed the city's engineers and inspectors on various job site visits and weekly meetings. Was an interim city inspector and provided daily construction reports and calculations. Worked in the field plotting GPS/GIS points to update the city's map of water and sewer lines. Was a member of a committee for consultant selection where duties included reviewing and interviewing consulting firms for capital improvement projects. Assisted with grant applications and researching grant opportunities for the city.

**Education:**

Washington State University, Bachelor of Science in Civil Engineering-Structural Emphasis.  
August 2007 - May 2012

Bellarmine Preparatory School, High School Diploma. September 2003 - June 2007

**Certifications:**

State of Washington Professional Engineer – License No. 23018582

**Training/Memberships:**

WSDOT Administrative Settlement Course - 4/6/16

WSDOT Sufficient Property Rights Training - 3/25/16

WSDOT No Right of Way (ROW) Verification - 4/14/16

Real Estate Acquisition Under the Uniform Act: An Overview - FHWA-NHI141045 -4/13/16

Local Public Agency Real Estate Acquisition - FHWA-NHI-141047 - 4/8/16

NW Public Works Institute - Public Works Essentials - 2/25/14

Member of American Public Works Association Washington Chapter - 9/2015 to Present

# Courtney L. Littrell, E.I.T.

courtneyl@sumnerwa.gov

(253) 299-5710

## Experience

### **Assistant Engineering Manager, City of Sumner**

Sumner, Washington

(Jan 2025-Present)

- Manage Engineering Specialists to complete projects and work through problems that arise
- Attend various City meetings to weigh in on policy decisions and present to City Council
- Provide project management and administrative support for Capital Improvement Projects funded by utilities and grants (TIB, WSDOT, FHWA)

### **Engineering Specialist, City of Sumner**

Sumner, Washington

(Aug 2022-Dec 2024)

- Managed transportation projects in different stages of design and construction
- Managed and developed the City's Sidewalk Program, which included the Helping Homeowners Program, Street Tree Program, and the ADA Program
- Lead construction meetings both before the project began and during the project duration

### **Permit Reviewer, Seattle Department of Transportation**

Seattle, Washington

(Jan 2020-Jul 2022)

- Reviewed complex Right-of-Way impacts associated with new and existing utility connections and construction work, and identified various secondary reviewers
- Assisted Leads and Supervisors with high priority permit applications and with status checks for major utilities
- Assisted contractors and homeowners with submitting a complete application for review via phone, in person, and over virtual meetings
- Lead meetings with contractors and stakeholders within the City of Seattle about large developments to better coordinate the work and to minimize the impacts to the Right-of-Way

### **Permit Specialist, Seattle Department of Transportation**

Seattle, Washington

(Oct 2019-Jan 2020)

- Reviewed emergency and side sewer permit applications for same day issuance
- Reviewed single review permit applications for low impacts to the Right-of-Way on non-arterial street segments associated with utilities and construction related activity
- Assisted contractors and homeowners with submitting a complete application, and ensuring that all the proposed impacts are covered on the permit that would be issued

## Education

### **Bachelor of Science in Civil Engineering, Washington State University**

Pullman, Washington

(Aug 2016-May 2019)

## Achievements

- APWA-WA Chapter Project of the Year Award – Main and Wood, April 2025
- Values Award – December 2023
- Water Resources Science Management Undergraduate Certificate

**Training**

WSDOT Local Programs – No ROW Verification Training (3/6/2026)

WSDOT Local Programs – Administrative Settlement Documentation (3/6/2026)

---

**SUBJECT:** Neighborhood Traffic Calming and Intersection Data Collection -  
Consultant Contract Award

**CATEGORY:** Consent

---

**BUDGET IMPACT:**

Expenditure Required: \$127,389.41

Within Budget Allocation: Yes

---

**ATTACHMENTS:**

1. Consultant Agreement w/ Scope and Fee

**STAFF CONTACT:** Michael Kosa, Public Works Director

---

**SUMMARY BACKGROUND:**

The City received a federally-funded Highway Safety Improvement Program (HSIP) grant for the planning phase of the Neighborhood Traffic Calming and Intersection Data Collection project. This project is focused on evaluating whether safety and mobility improvements are appropriate at several locations throughout the City. The scope of work includes collecting traffic and roadway data, conducting intersection operational analyses, and performing studies to identify whether there are appropriate and feasible traffic-calming improvements necessary.

Six (6) Statement of Qualifications were received on December 17, 2020 for this project. SCJ Alliance was selected to provide consulting services for this project through a qualification-based selection process. An agreement with a maximum amount payable of \$127,389.41 was negotiated for the planning phase of the project.

---

<p><b>COUNCIL COMMITTEE/STUDY SESSION:</b> Public Works Committee <b>MEETING/STUDY SESSION DATE:</b> 4/21/2026 <b>COMMITTEE RECOMMENDATION:</b> Do Pass</p>
---

**STAFF RECOMMENDATIONS/MOTION:**

A motion authorizing the Mayor and City Administrator to execute all necessary contract documents with SCJ Alliance, in an amount not-to-exceed \$127,389.41 for the Neighborhood Traffic Calming and Intersection Data Collection (CIP 24-07), substantially in a form approved by the City Attorney.

# Local Agency A&E Professional Services Negotiated Hourly Rate Consultant Agreement

Agreement Number: LA11212

Firm/Organization Legal Name (do not use dba's):	
Address	Federal Aid Number
UBI Number	Federal TIN
Execution Date	Completion Date
1099 Form Required <input type="checkbox"/> Yes <input type="checkbox"/> No	Federal Participation <input type="checkbox"/> Yes <input type="checkbox"/> No
Project Title	
Description of Work	
<input type="checkbox"/> Yes <input type="checkbox"/> No DBE Participation <input type="checkbox"/> Yes <input type="checkbox"/> No MBE Participation <input type="checkbox"/> Yes <input type="checkbox"/> No WBE Participation <input type="checkbox"/> Yes <input type="checkbox"/> No SBE Participation	Maximum Amount Payable: \$127,389.41

## Index of Exhibits

- Exhibit A      Scope of Work
- Exhibit B      DBE Participation
- Exhibit C      Preparation and Delivery of Electronic Engineering and Other Data
- Exhibit D      Prime Consultant Cost Computations
- Exhibit E      Sub-consultant Cost Computations
- Exhibit F      Title VI Assurances
- Exhibit G      Certification Documents
- Exhibit H      Liability Insurance Increase
- Exhibit I      Alleged Consultant Design Error Procedures
- Exhibit J      Consultant Claim Procedures

THIS AGREEMENT, made and entered into as shown in the “Execution Date” box on page one (1) of this AGREEMENT, between the \_\_\_\_\_, hereinafter called the “AGENCY,” and the “Firm / Organization Name” referenced on page one (1) of this AGREEMENT, hereinafter called the “CONSULTANT.”

WHEREAS, the AGENCY desires to accomplish the work referenced in “Description of Work” on page one (1) of this AGREEMENT and hereafter called the “SERVICES;” and does not have sufficient staff to meet the required commitment and therefore deems it advisable and desirable to engage the assistance of a CONSULTANT to provide the necessary SERVICES; and

WHEREAS, the CONSULTANT represents that they comply with the Washington State Statutes relating to professional registration, if applicable, and has signified a willingness to furnish consulting services to the AGENCY.

NOW, THEREFORE, in consideration of the terms, conditions, covenants, and performance contained herein, or attached and incorporated and made a part hereof, the parties hereto agree as follows:

## **I. General Description of Work**

The work under this AGREEMENT shall consist of the above-described SERVICES as herein defined, and necessary to accomplish the completed work for this project. The CONSULTANT shall furnish all services, labor, and related equipment and, if applicable, sub-consultants and subcontractors necessary to conduct and complete the SERVICES as designated elsewhere in this AGREEMENT.

## **II. General Scope of Work**

The Scope of Work and projected level of effort required for these SERVICES is described in Exhibit “A” attached hereto and by this reference made a part of this AGREEMENT. The General Scope of Work was developed utilizing performance based contracting methodologies.

## **III. General Requirements**

All aspects of coordination of the work of this AGREEMENT with outside agencies, groups, or individuals shall receive advance approval by the AGENCY. Necessary contacts and meetings with agencies, groups, and/or individuals shall be coordinated through the AGENCY. The CONSULTANT shall attend coordination, progress, and presentation meetings with the AGENCY and/or such State, Federal, Community, City, or County officials, groups or individuals as may be requested by the AGENCY. The AGENCY will provide the CONSULTANT sufficient notice prior to meetings requiring CONSULTANT participation. The minimum required hours or days’ notice shall be agreed to between the AGENCY and the CONSULTANT and shown in Exhibit “A.”

The CONSULTANT shall prepare a monthly progress report, in a form approved by the AGENCY, which will outline in written and graphical form the various phases and the order of performance of the SERVICES in sufficient detail so that the progress of the SERVICES can easily be evaluated.

The CONSULTANT, any sub-consultants, and the AGENCY shall comply with all Federal, State, and local laws, rules, codes, regulations, and all AGENCY policies and directives, applicable to the work to be performed under this AGREEMENT. This AGREEMENT shall be interpreted and construed in accordance with the laws of the State of Washington.

Participation for Disadvantaged Business Enterprises (DBE) or Small Business Enterprises (SBE), if required, per 49 CFR Part 26, shall be shown on the heading of this AGREEMENT. If DBE firms are utilized at the commencement of this AGREEMENT, the amounts authorized to each firm and their certification number will be shown on Exhibit "B" attached hereto and by this reference made part of this AGREEMENT. If the Prime CONSULTANT is, a DBE certified firm they must comply with the Commercial Useful Function (CUF) regulation outlined in the AGENCY's "DBE Program Participation Plan" and perform a minimum of 30% of the total amount of this AGREEMENT. It is recommended, but not required, that non-DBE Prime CONSULTANTS perform a minimum of 30% of the total amount of this AGREEMENT.

In the absence of a mandatory DBE goal, a voluntary SBE goal amount of ten percent of the Consultant Agreement is established. The Consultant shall develop a SBE Participation Plan prior to commencing work. Although the goal is voluntary, the outreach efforts to provide SBE maximum practicable opportunities are not.

The CONSULTANT, on a monthly basis, shall enter the amounts paid to all firms (including Prime) involved with this AGREEMENT into the [wsdot.diversitycompliance.com](http://wsdot.diversitycompliance.com) program. Payment information shall identify any DBE Participation.

All Reports, PS&E materials, and other data furnished to the CONSULTANT by the AGENCY shall be returned. All electronic files, prepared by the CONSULTANT, must meet the requirements as outlined in Exhibit "C – Preparation and Delivery of Electronic Engineering and other Data."

All designs, drawings, specifications, documents, and other work products, including all electronic files, prepared by the CONSULTANT prior to completion or termination of this AGREEMENT are instruments of service for these SERVICES, and are the property of the AGENCY. Reuse by the AGENCY or by others, acting through or on behalf of the AGENCY of any such instruments of service, not occurring, as a part of this SERVICE, shall be without liability or legal exposure to the CONSULTANT.

Any and all notices or requests required under this AGREEMENT shall be made in writing and sent to the other party by (i) certified mail, return receipt requested, or (ii) by email or facsimile, to the address set forth below:

If to AGENCY:

Name:  
Agency:  
Address:  
City:                      State:              Zip:  
Email:  
Phone:  
Facsimile:

If to CONSULTANT:

Name:  
Agency:  
Address:  
City:                      State:              Zip:  
Email:  
Phone:  
Facsimile:

#### **IV. Time for Beginning and Completion**

The CONSULTANT shall not begin any work under the terms of this AGREEMENT until authorized in writing by the AGENCY. All work under this AGREEMENT shall conform to the criteria agreed upon detailed in the AGREEMENT documents. These SERVICES must be completed by the date shown in the heading of this AGREEMENT titled "Completion Date."

The established completion time shall not be extended because of any delays attributable to the CONSULTANT, but may be extended by the AGENCY in the event of a delay attributable to the AGENCY, or because of unavoidable delays caused by an act of GOD, governmental actions, or other conditions beyond the control of the CONSULTANT. A prior supplemental AGREEMENT issued by the AGENCY is required to extend the established completion time.

## V. Payment Provisions

The CONSULTANT shall be paid by the AGENCY for completed SERVICES rendered under this AGREEMENT as provided hereinafter. Such payment shall be full compensation for SERVICES performed or SERVICES rendered and for all labor, materials, supplies, equipment, and incidentals necessary to complete SERVICES. The CONSULTANT shall conform to all applicable portions of 48 CFR Part 31 ([www.ecfr.gov](http://www.ecfr.gov)).

- A. Hourly Rates: Hourly rates are comprised of the following elements - Direct (Raw) Labor, Indirect Cost Rate, and Fee (Profit). The CONSULTANT shall be paid by the AGENCY for work done, based upon the negotiated hourly rates shown in Exhibits "D" and "E" attached hereto and by reference made part of this AGREEMENT. These negotiated hourly rates will be accepted based on a review of the CONSULTANT's direct labor rates and indirect cost rate computations and agreed upon fee. The accepted negotiated rates shall be memorialized in a final written acknowledgment between the parties. Such final written acknowledgment shall be incorporated into, and become a part of, this AGREEMENT. The initially accepted negotiated rates shall be applicable from the approval date, as memorialized in a final written acknowledgment, to 180 days following the CONSULTANT's fiscal year end (FYE) date.

The direct (raw) labor rates and classifications, as shown on Exhibits "D" and "E" shall be subject to renegotiations for each subsequent twelve (12) month period (180 days following FYE date to 180 days following FYE date) upon written request of the CONSULTANT or the AGENCY. The written request must be made to the other party within ninety (90) days following the CONSULTANT's FYE date. If no such written request is made, the current direct (raw) labor rates and classifications as shown on Exhibits "D" and "E" will remain in effect for the twelve (12) month period.

Conversely, if a timely request is made in the manner set forth above, the parties will commence negotiations to determine the new direct (raw) labor rates and classifications that will be applicable for the twelve (12) month period. Any agreed to renegotiated rates shall be memorialized in a final written acknowledgment between the parties. Such final written acknowledgment shall be incorporated into, and become a part of, this AGREEMENT. If requested, the CONSULTANT shall provide current payroll register and classifications to aid in negotiations. If the parties cannot reach an agreement on the direct (raw) labor rates and classifications, the AGENCY shall perform an audit of the CONSULTANT's books and records to determine the CONSULTANT's actual costs. The audit findings will establish the direct (raw) labor rates and classifications that will be applicable for the twelve (12) month period.

The fee as identified in Exhibits "D" and "E" shall represent a value to be applied throughout the life of the AGREEMENT.

The CONSULTANT shall submit annually to the AGENCY an updated indirect cost rate within 180 days of the close of its fiscal year. An approved updated indirect cost rate shall be included in the current fiscal year rate under this AGREEMENT, even if/when other components of the hourly rate are not renegotiated. These rates will be applicable for the twelve (12) month period. At the AGENCY's option, a provisional and/or conditional indirect cost rate may be negotiated. This provisional or conditional indirect rate shall remain in effect until the updated indirect cost rate is completed and approved. Indirect cost rate costs incurred during the provisional or conditional period will not be adjusted. The CONSULTANT may request an extension of the last approved indirect cost rate for the twelve (12) month period. These requests for provisional indirect cost rate and/or extension will be considered on a case-by-case basis, and if granted, will be memorialized in a final written acknowledgment.

The CONSULTANT shall maintain and have accessible support data for verification of the components of the hourly rates, i.e., direct (raw) labor, indirect cost rate, and fee (profit) percentage. The CONSULTANT shall bill each employee's actual classification, and actual salary plus indirect cost rate plus fee.

- A. Direct Non-Salary Costs: Direct Non-Salary Costs will be reimbursed at the actual cost to the CONSULTANT. These charges may include, but are not limited to, the following items: travel, printing, long distance telephone, supplies, computer charges, and fees of sub-consultants. Air or train travel will be reimbursed only to lowest price available, unless otherwise approved by the AGENCY. The CONSULTANT shall comply with the rules and regulations regarding travel costs (excluding air, train, and rental car costs) in accordance with the WSDOT's Accounting Manual M 13-82, Chapter 10 – Travel Rules and Procedures, and all revisions thereto. Air, train, and rental card costs shall be reimbursed in accordance with 48 Code of Federal Regulations (CFR) Part 31.205-46 "Travel Costs." The billing for Direct Non-salary Costs shall include an itemized listing of the charges directly identifiable with these SERVICES. The CONSULTANT shall maintain the original supporting documents in their office. Copies of the original supporting documents shall be supplied to the STATE upon request. All above charges must be necessary for the SERVICES provided under this AGREEMENT.
- B. Maximum Amount Payable: The Maximum Amount Payable by the AGENCY to the CONSULTANT under this AGREEMENT shall not exceed the amount shown in the heading of this AGREEMENT on page one (1.) The Maximum Amount Payable does not include payment for extra work as stipulated in section XIII, "Extra Work." No minimum amount payable is guaranteed under this AGREEMENT.
- C. Monthly Progress Payments: Progress payments may be claimed on a monthly basis for all costs authorized in A and B above. Detailed statements shall support the monthly billings for hours expended at the rates established in Exhibit "D," including names and classifications of all employees, and billings for all direct non-salary expenses. To provide a means of verifying the billed salary costs for the CONSULTANT's employees, the AGENCY may conduct employee interviews. These interviews may consist of recording the names, titles, salary rates, and present duties of those employees performing work on the SERVICES at the time of the interview.
- D. Final Payment: Final Payment of any balance due the CONSULTANT of the gross amount earned will be made promptly upon its verification by the AGENCY after the completion of the SERVICES under this AGREEMENT, contingent upon receipt of all PS&E, plans, maps, notes, reports, electronic data, and other related documents, which are required to be furnished under this AGREEMENT. Acceptance of such Final Payment by the CONSULTANT shall constitute a release of all claims for payment, which the CONSULTANT may have against the AGENCY unless such claims are specifically reserved in writing and transmitted to the AGENCY by the CONSULTANT prior to its acceptance. Said Final Payment shall not, however, be a bar to any claims that the AGENCY may have against the CONSULTANT or to any remedies the AGENCY may pursue with respect to such claims.

The payment of any billing will not constitute agreement as to the appropriateness of any item and at the time of final audit all required adjustments will be made and reflected in a final payment. In the event that such final audit reveals an overpayment to the CONSULTANT, the CONSULTANT will refund such overpayment to the AGENCY within thirty (30) calendar days of notice of the overpayment. Such refund shall not constitute a waiver by the CONSULTANT for any claims relating to the validity of a finding by the AGENCY of overpayment. Per WSDOT's "Audit Guide for Consultants," Chapter 23 "Resolution Procedures," the CONSULTANT has twenty (20) working days after receipt of the final Post Audit to begin the appeal process to the AGENCY for audit findings

E. Inspection of Cost Records: The CONSULTANT and their sub-consultants shall keep available for inspection by representatives of the AGENCY and the United States, for a period of six (6) years after receipt of final payment, the cost records and accounts pertaining to this AGREEMENT and all items related to or bearing upon these records with the following exception: if any litigation, claim or audit arising out of, in connection with, or related to this AGREEMENT is initiated before the expiration of the six (6) year period, the cost records and accounts shall be retained until such litigation, claim, or audit involving the records is completed. An interim or post audit may be performed on this AGREEMENT. The audit, if any, will be performed by the State Auditor, WSDOT's Internal Audit Office and /or at the request of the AGENCY's Project Manager.

## **VI. Sub-Contracting**

The AGENCY permits subcontracts for those items of SERVICES as shown in Exhibit "A" attached hereto and by this reference made part of this AGREEMENT.

The CONSULTANT shall not subcontract for the performance of any SERVICE under this AGREEMENT without prior written permission of the AGENCY. No permission for subcontracting shall create, between the AGENCY and sub-consultant, any contract or any other relationship.

Compensation for this sub-consultant SERVICES shall be based on the cost factors shown on Exhibit "E" attached hereto and by this reference made part of this AGREEMENT.

The SERVICES of the sub-consultant shall not exceed its maximum amount payable identified in each sub consultant cost estimate unless a prior written approval has been issued by the AGENCY.

All reimbursable direct labor, indirect cost rate, direct non-salary costs and fee costs for the sub-consultant shall be negotiated and substantiated in accordance with section V "Payment Provisions" herein and shall be memorialized in a final written acknowledgment between the parties

All subcontracts shall contain all applicable provisions of this AGREEMENT, and the CONSULTANT shall require each sub-consultant or subcontractor, of any tier, to abide by the terms and conditions of this AGREEMENT. With respect to sub-consultant payment, the CONSULTANT shall comply with all applicable sections of the STATE's Prompt Payment laws as set forth in RCW 39.04.250 and RCW 39.76.011.

The CONSULTANT, sub-recipient, or sub-consultant shall not discriminate on the basis of race, color, national origin, or sex in the performance of this AGREEMENT. The CONSULTANT shall carry out applicable requirements of 49 CFR Part 26 in the award and administration of DOT-assisted contracts. Failure by the CONSULTANT to carry out these requirements is a material breach of this AGREEMENT, which may result in the termination of this AGREEMENT or such other remedy as the recipient deems appropriate.

## **VII. Employment and Organizational Conflict of Interest**

The CONSULTANT warrants that they have not employed or retained any company or person, other than a bona fide employee working solely for the CONSULTANT, to solicit or secure this contract, and that it has not paid or agreed to pay any company or person, other than a bona fide employee working solely for the CONSULTANT, any fee, commission, percentage, brokerage fee, gift, or any other consideration, contingent upon or resulting from the award or making of this agreement. For breach or violation of this warrant, the AGENCY shall have the right to annul this AGREEMENT without liability or, in its discretion, to deduct from this AGREEMENT price or consideration or otherwise recover the full amount of such fee, commission, percentage, brokerage fee, gift, or contingent fee.

Any and all employees of the CONSULTANT or other persons while engaged in the performance of any work or services required of the CONSULTANT under this AGREEMENT, shall be considered employees of the CONSULTANT only and not of the AGENCY, and any and all claims that may arise under any Workmen's Compensation Act on behalf of said employees or other persons while so engaged, and any and all claims made by a third party as a consequence of any act or omission on the part of the CONSULTANT's employees or other persons while so engaged on any of the work or services provided to be rendered herein, shall be the sole obligation and responsibility of the CONSULTANT.

The CONSULTANT shall not engage, on a full- or part-time basis, or other basis, during the period of this AGREEMENT, any professional or technical personnel who are, or have been, at any time during the period of this AGREEMENT, in the employ of the United States Department of Transportation or the AGENCY, except regularly retired employees, without written consent of the public employer of such person if he/she will be working on this AGREEMENT for the CONSULTANT.

Agreement Number:

## VIII. Nondiscrimination

During the performance of this AGREEMENT, the CONSULTANT, for itself, its assignees, sub-consultants, subcontractors and successors in interest, agrees to comply with the following laws and regulations:

- Title VI of the Civil Rights Act of 1964 (42 U.S.C. Chapter 21 Subchapter V § 2000d through 2000d-4a)
- Federal-aid Highway Act of 1973 (23 U.S.C. Chapter 3 § 324)
- Rehabilitation Act of 1973 (29 U.S.C. Chapter 16 Subchapter V § 794)
- Age Discrimination Act of 1975 (42 U.S.C. Chapter 76 § 6101 *et. seq.*)
- Civil Rights Restoration Act of 1987 (Public Law 100-259)
- American with Disabilities Act of 1990 (42 U.S.C. Chapter 126 § 12101 *et. seq.*)
- 23 CFR Part 200
- 49 CFR Part 21
- 49 CFR Part 26
- RCW 49.60.180

In relation to Title VI of the Civil Rights Act of 1964, the CONSULTANT is bound by the provisions of Exhibit “F” attached hereto and by this reference made part of this AGREEMENT, and shall include the attached Exhibit “F” in every sub-contract, including procurement of materials and leases of equipment, unless exempt by the Regulations or directives issued pursuant thereto.

## IX. Termination of Agreement

The right is reserved by the AGENCY to terminate this AGREEMENT at any time with or without cause upon ten (10) days written notice to the CONSULTANT.

In the event this AGREEMENT is terminated by the AGENCY, other than for default on the part of the CONSULTANT, a final payment shall be made to the CONSULTANT for actual hours charged at the time of termination of this AGREEMENT, plus any direct non-salary costs incurred up to the time of termination of this AGREEMENT.

No payment shall be made for any SERVICES completed after ten (10) days following receipt by the CONSULTANT of the notice to terminate. If the accumulated payment made to the CONSULTANT prior to Notice of Termination exceeds the total amount that would be due when computed as set forth in paragraph two (2) of this section, then no final payment shall be due and the CONSULTANT shall immediately reimburse the AGENCY for any excess paid.

If the services of the CONSULTANT are terminated by the AGENCY for default on the part of the CONSULTANT, the above formula for payment shall not apply.

In the event of a termination for default, the amount to be paid to the CONSULTANT shall be determined by the AGENCY with consideration given to the actual costs incurred by the CONSULTANT in performing SERVICES to the date of termination, the amount of SERVICES originally required which was satisfactorily completed to date of termination, whether that SERVICE is in a form or a type which is usable to the AGENCY at the time of termination, the cost to the AGENCY of employing another firm to complete the SERVICES required and the time which may be required to do so, and other factors which affect the value to the AGENCY of the SERVICES performed at the time of termination. Under no circumstances shall payment made under this subsection exceed the amount, which would have been made using the formula set forth in paragraph two (2) of this section.

If it is determined for any reason, that the CONSULTANT was not in default or that the CONSULTANT’s failure to perform is without the CONSULTANT’s or its employee’s fault or negligence, the termination shall be deemed to be a termination for the convenience of the AGENCY. In such an event, the CONSULTANT would be reimbursed for actual costs in accordance with the termination for other than default clauses listed previously.

The CONSULTANT shall, within 15 days, notify the AGENCY in writing, in the event of the death of any member, partner, or officer of the CONSULTANT or the death or change of any of the CONSULTANT's supervisory and/or other key personnel assigned to the project or disaffiliation of any principally involved CONSULTANT employee.

The CONSULTANT shall also notify the AGENCY, in writing, in the event of the sale or transfer of 50% or more of the beneficial ownership of the CONSULTANT within 15 days of such sale or transfer occurring. The CONSULTANT shall continue to be obligated to complete the SERVICES under the terms of this AGREEMENT unless the AGENCY chooses to terminate this AGREEMENT for convenience or chooses to renegotiate any term(s) of this AGREEMENT. If termination for convenience occurs, final payment will be made to the CONSULTANT as set forth in the second and third paragraphs of this section.

Payment for any part of the SERVICES by the AGENCY shall not constitute a waiver by the AGENCY of any remedies of any type it may have against the CONSULTANT for any breach of this AGREEMENT by the CONSULTANT, or for failure of the CONSULTANT to perform SERVICES required of it by the AGENCY.

Forbearance of any rights under the AGREEMENT will not constitute waiver of entitlement to exercise those rights with respect to any future act or omission by the CONSULTANT.

## **X. Changes of Work**

The CONSULTANT shall make such changes and revisions in the completed work of this AGREEMENT as necessary to correct errors appearing therein, without additional compensation thereof. Should the AGENCY find it desirable for its own purposes to have previously satisfactorily completed SERVICES or parts thereof changed or revised, the CONSULTANT shall make such revisions as directed by the AGENCY. This work shall be considered as Extra Work and will be paid for as herein provided under section XIII "Extra Work."

## **XI. Disputes**

Any disputed issue not resolved pursuant to the terms of this AGREEMENT shall be submitted in writing within 10 days to the Director of Public Works or AGENCY Engineer, whose decision in the matter shall be final and binding on the parties of this AGREEMENT; provided however, that if an action is brought challenging the Director of Public Works or AGENCY Engineer's decision, that decision shall be subject to judicial review. If the parties to this AGREEMENT mutually agree, disputes concerning alleged design errors will be conducted under the procedures found in Exhibit "J". In the event that either party deem it necessary to institute legal action or proceeding to enforce any right or obligation under this AGREEMENT, this action shall be initiated in the Superior Court of the State of Washington, situated in the county in which the AGENCY is located. The parties hereto agree that all questions shall be resolved by application of Washington law and that the parties have the right of appeal from such decisions of the Superior Court in accordance with the laws of the State of Washington. The CONSULTANT hereby consents to the personal jurisdiction of the Superior Court of the State of Washington, situated in the county in which the AGENCY is located.

## **XII. Legal Relations**

The CONSULTANT, any sub-consultants, and the AGENCY shall comply with all Federal, State, and local laws, rules, codes, regulations and all AGENCY policies and directives, applicable to the work to be performed under this AGREEMENT. This AGREEMENT shall be interpreted and construed in accordance with the laws of the State of Washington.

The CONSULTANT shall defend, indemnify, and hold the State of Washington (STATE) and the AGENCY and their officers and employees harmless from all claims, demands, or suits at law or equity arising in whole or in part from the negligence of, or the breach of any obligation under this AGREEMENT by, the CONSULTANT or the CONSULTANT's agents, employees, sub consultants, subcontractors or vendors, of any tier, or any other persons for whom the CONSULTANT may be legally liable; provided that nothing herein shall require a CONSULTANT

to defend or indemnify the STATE and the AGENCY and their officers and employees against and hold harmless the STATE and the AGENCY and their officers and employees from claims, demands or suits based solely upon the negligence of, or breach of any obligation under this AGREEMENT by the STATE and the AGENCY, their agents, officers, employees, sub-consultants, subcontractors or vendors, of any tier, or any other persons for whom the STATE and /or the AGENCY may be legally liable; and provided further that if the claims or suits are caused by or result from the concurrent negligence of (a) the CONSULTANT or the CONSULTANT's agents, employees, sub-consultants, subcontractors or vendors, of any tier, or any other persons for whom the CONSULTANT is legally liable, and (b) the STATE and/or AGENCY, their agents, officers, employees, sub-consultants, subcontractors and or vendors, of any tier, or any other persons for whom the STATE and/or AGENCY may be legally liable, the defense and indemnity obligation shall be valid and enforceable only to the extent of the CONSULTANT's negligence or the negligence of the CONSULTANT's agents, employees, sub-consultants, subcontractors or vendors, of any tier, or any other persons for whom the CONSULTANT may be legally liable. This provision shall be included in any AGREEMENT between CONSULTANT and any sub-consultant, subcontractor and vendor, of any tier.

The CONSULTANT shall also defend, indemnify, and hold the STATE and the AGENCY and their officers and employees harmless from all claims, demands, or suits at law or equity arising in whole or in part from the alleged patent or copyright infringement or other allegedly improper appropriation or use of trade secrets, patents, proprietary information, know-how, copyright rights or inventions by the CONSULTANT or the CONSULTANT's agents, employees, sub-consultants, subcontractors or vendors, of any tier, or any other persons for whom the CONSULTANT may be legally liable, in performance of the Work under this AGREEMENT or arising out of any use in connection with the AGREEMENT of methods, processes, designs, information or other items furnished or communicated to STATE and/or the AGENCY, their agents, officers and employees pursuant to the AGREEMENT; provided that this indemnity shall not apply to any alleged patent or copyright infringement or other allegedly improper appropriation or use of trade secrets, patents, proprietary information, know-how, copyright rights or inventions resulting from STATE and/or AGENCY's, their agents', officers and employees' failure to comply with specific written instructions regarding use provided to STATE and/or AGENCY, their agents, officers and employees by the CONSULTANT, its agents, employees, sub-consultants, subcontractors or vendors, of any tier, or any other persons for whom the CONSULTANT may be legally liable.

The CONSULTANT's relation to the AGENCY shall be at all times as an independent contractor.

Notwithstanding any determination by the Executive Ethics Board or other tribunal, the AGENCY may, in its sole discretion, by written notice to the CONSULTANT terminate this AGREEMENT if it is found after due notice and examination by the AGENCY that there is a violation of the Ethics in Public Service Act, Chapter 42.52 RCW; or any similar statute involving the CONSULTANT in the procurement of, or performance under, this AGREEMENT.

The CONSULTANT specifically assumes potential liability for actions brought by the CONSULTANT's own employees or its agents against the STATE and/or the AGENCY and, solely for the purpose of this indemnification and defense, the CONSULTANT specifically waives any immunity under the state industrial insurance law, Title 51 RCW. The Parties have mutually negotiated this waiver.

Unless otherwise specified in this AGREEMENT, the AGENCY shall be responsible for administration of construction contracts, if any, on the project. Subject to the processing of a new sole source, or an acceptable supplemental AGREEMENT, the CONSULTANT shall provide On-Call assistance to the AGENCY during contract administration. By providing such assistance, the CONSULTANT shall assume no responsibility for proper construction techniques, job site safety, or any construction contractor's failure to perform its work in accordance with the contract documents.

The CONSULTANT shall obtain and keep in force during the terms of this AGREEMENT, or as otherwise required, the following insurance with companies or through sources approved by the State Insurance Commissioner pursuant to Title 48 RCW.

Insurance Coverage

- A. Worker’s compensation and employer’s liability insurance as required by the STATE.
- B. Commercial general liability insurance written under ISO Form CG 00 01 12 04 or its equivalent with minimum limits of one million dollars (\$1,000,000.00) per occurrence and two million dollars (\$2,000,000.00) in the aggregate for each policy period.
- C. Business auto liability insurance written under ISO Form CG 00 01 10 01 or equivalent providing coverage for any “Auto” (Symbol 1) used in an amount not less than a one million dollar (\$1,000,000.00) combined single limit for each occurrence.

Excepting the Worker’s Compensation Insurance and any Professional Liability Insurance, the STATE and AGENCY, their officers, employees, and agents will be named on all policies of CONSULTANT and any sub-consultant and/or subcontractor as an additional insured (the “AIs”), with no restrictions or limitations concerning products and completed operations coverage. This coverage shall be primary coverage and non-contributory and any coverage maintained by the AIs shall be excess over, and shall not contribute with, the additional insured coverage required hereunder. The CONSULTANT’s and the sub-consultant’s and/or subcontractor’s insurer shall waive any and all rights of subrogation against the AIs. The CONSULTANT shall furnish the AGENCY with verification of insurance and endorsements required by this AGREEMENT. The AGENCY reserves the right to require complete, certified copies of all required insurance policies at any time.

All insurance shall be obtained from an insurance company authorized to do business in the State of Washington. The CONSULTANT shall submit a verification of insurance as outlined above within fourteen (14) days of the execution of this AGREEMENT to:

Name:  
 Agency:  
 Address:  
 City: State: Zip:  
 Email:  
 Phone:  
 Facsimile:

No cancellation of the foregoing policies shall be effective without thirty (30) days prior notice to the AGENCY.

The CONSULTANT’s professional liability to the AGENCY, including that which may arise in reference to section IX “Termination of Agreement” of this AGREEMENT, shall be limited to the accumulative amount of the authorized AGREEMENT or one million dollars (\$1,000,000.00), whichever is greater, unless the limit of liability is increased by the AGENCY pursuant to Exhibit H. In no case shall the CONSULTANT’s professional liability to third parties be limited in any way.

The parties enter into this AGREEMENT for the sole benefit of the parties, and to the exclusion of any third party, and no third party beneficiary is intended or created by the execution of this AGREEMENT.

The AGENCY will pay no progress payments under section V “Payment Provisions” until the CONSULTANT has fully complied with this section. This remedy is not exclusive; and the AGENCY may take such other action as is available to it under other provisions of this AGREEMENT, or otherwise in law.

### **XIII. Extra Work**

- A. The AGENCY may at any time, by written order, make changes within the general scope of this AGREEMENT in the SERVICES to be performed.
- B. If any such change causes an increase or decrease in the estimated cost of, or the time required for, performance of any part of the SERVICES under this AGREEMENT, whether or not changed by the order, or otherwise affects any other terms and conditions of this AGREEMENT, the AGENCY shall make an equitable adjustment in the: (1) maximum amount payable; (2) delivery or completion schedule, or both; and (3) other affected terms and shall modify this AGREEMENT accordingly.
- C. The CONSULTANT must submit any “request for equitable adjustment,” hereafter referred to as “CLAIM,” under this clause within thirty (30) days from the date of receipt of the written order. However, if the AGENCY decides that the facts justify it, the AGENCY may receive and act upon a CLAIM submitted before final payment of this AGREEMENT.
- D. Failure to agree to any adjustment shall be a dispute under the section XI “Disputes” clause. However, nothing in this clause shall excuse the CONSULTANT from proceeding with the AGREEMENT as changed.
- E. Notwithstanding the terms and conditions of paragraphs (A.) and (B.) above, the maximum amount payable for this AGREEMENT, shall not be increased or considered to be increased except by specific written supplement to this AGREEMENT.

### **XIV. Endorsement of Plans**

If applicable, the CONSULTANT shall place their endorsement on all plans, estimates, or any other engineering data furnished by them.

### **XV. Federal Review**

The Federal Highway Administration shall have the right to participate in the review or examination of the SERVICES in progress.

### **XVI. Certification of the Consultant and the Agency**

Attached hereto as Exhibit “G-1(a and b)” are the Certifications of the CONSULTANT and the AGENCY, Exhibit “G-2” Certification Regarding Debarment, Suspension and Other Responsibility Matters - Primary Covered Transactions, Exhibit “G-3” Certification Regarding the Restrictions of the Use of Federal Funds for Lobbying and Exhibit “G-4” Certificate of Current Cost or Pricing Data. Exhibit “G-3” is required only in AGREEMENTS over one hundred thousand dollars (\$100,000.00) and Exhibit “G-4” is required only in AGREEMENTS over five hundred thousand dollars (\$500,000.00.) These Exhibits must be executed by the CONSULTANT, and submitted with the master AGREEMENT, and returned to the AGENCY at the address listed in section III “General Requirements” prior to its performance of any SERVICES under this AGREEMENT.

### **XVII. Complete Agreement**

This document and referenced attachments contain all covenants, stipulations, and provisions agreed upon by the parties. No agent, or representative of either party has authority to make, and the parties shall not be bound by or be liable for, any statement, representation, promise or agreement not set forth herein. No changes, amendments, or modifications of the terms hereof shall be valid unless reduced to writing and signed by the parties as a supplement to this AGREEMENT.

### **XVIII. Execution and Acceptance**

This AGREEMENT may be simultaneously executed in several counterparts, each of which shall be deemed to be an original having identical legal effect. The CONSULTANT does hereby ratify and adopt all statements, representations, warranties, covenants, and AGREEMENT’s contained in the proposal, and the supporting material submitted by the CONSULTANT, and does hereby accept this AGREEMENT and agrees to all of the terms and conditions thereof.

## **XIX. Protection of Confidential Information**

The CONSULTANT acknowledges that some of the material and information that may come into its possession or knowledge in connection with this AGREEMENT or its performance may consist of information that is exempt from disclosure to the public or other unauthorized persons under either chapter 42.56 RCW or other local, state, or federal statutes (“State’s Confidential Information”). The “State’s Confidential Information” includes, but is not limited to, names, addresses, Social Security numbers, e-mail addresses, telephone numbers, financial profiles credit card information, driver’s license numbers, medical data, law enforcement records (or any other information identifiable to an individual), STATE and AGENCY source code or object code, STATE and AGENCY security data, non-public Specifications, STATE and AGENCY non-publicly available data, proprietary software, STATE and AGENCY security data, or information which may jeopardize any part of the project that relates to any of these types of information. The CONSULTANT agrees to hold the State’s Confidential Information in strictest confidence and not to make use of the State’s Confidential Information for any purpose other than the performance of this AGREEMENT, to release it only to authorized employees, sub-consultants or subcontractors requiring such information for the purposes of carrying out this AGREEMENT, and not to release, divulge, publish, transfer, sell, disclose, or otherwise make it known to any other party without the AGENCY’s express written consent or as provided by law. The CONSULTANT agrees to release such information or material only to employees, sub-consultants or subcontractors who have signed a nondisclosure AGREEMENT, the terms of which have been previously approved by the AGENCY. The CONSULTANT agrees to implement physical, electronic, and managerial safeguards to prevent unauthorized access to the State’s Confidential Information.

Immediately upon expiration or termination of this AGREEMENT, the CONSULTANT shall, at the AGENCY’s option: (i) certify to the AGENCY that the CONSULTANT has destroyed all of the State’s Confidential Information; or (ii) returned all of the State’s Confidential Information to the AGENCY; or (iii) take whatever other steps the AGENCY requires of the CONSULTANT to protect the State’s Confidential Information.

As required under Executive Order 00-03, the CONSULTANT shall maintain a log documenting the following: the State’s Confidential Information received in the performance of this AGREEMENT; the purpose(s) for which the State’s Confidential Information was received; who received, maintained, and used the State’s Confidential Information; and the final disposition of the State’s Confidential Information. The CONSULTANT’s records shall be subject to inspection, review, or audit upon reasonable notice from the AGENCY.

The AGENCY reserves the right to monitor, audit, or investigate the use of the State’s Confidential Information collected, used, or acquired by the CONSULTANT through this AGREEMENT. The monitoring, auditing, or investigating may include, but is not limited to, salting databases.

Violation of this section by the CONSULTANT or its sub-consultants or subcontractors may result in termination of this AGREEMENT and demand for return of all State’s Confidential Information, monetary damages, or penalties

It is understood and acknowledged that the CONSULTANT may provide the AGENCY with information, which is proprietary and/or confidential during the term of this AGREEMENT. The parties agree to maintain the confidentiality of such information during the term of this AGREEMENT and afterwards. All materials containing such proprietary and/or confidential information shall be clearly identified and marked as “Confidential” and shall be returned to the disclosing party at the conclusion of the SERVICES under this AGREEMENT.

The CONSULTANT shall provide the AGENCY with a list of all information and materials it considers confidential and/or proprietary in nature: (a) at the commencement of the term of this AGREEMENT, or (b) as soon as such confidential or proprietary material is developed. "Proprietary and/or confidential information" is not meant to include any information which, at the time of its disclosure: (i) is already known to the other party; (ii) is rightfully disclosed to one of the parties by a third party that is not acting as an agent or representative for the other party; (iii) is independently developed by or for the other party; (iv) is publicly known; or (v) is generally utilized by unaffiliated third parties engaged in the same business or businesses as the CONSULTANT.

The parties also acknowledge that the AGENCY is subject to Washington State and federal public disclosure laws. As such, the AGENCY shall maintain the confidentiality of all such information marked proprietary and or confidential or otherwise exempt, unless such disclosure is required under applicable state or federal law. If a public disclosure request is made to view materials identified as "Proprietary and/or confidential information" or otherwise exempt information, the AGENCY will notify the CONSULTANT of the request and of the date that such records will be released to the requester unless the CONSULTANT obtains a court order from a court of competent jurisdiction enjoining that disclosure. If the CONSULTANT fails to obtain the court order enjoining disclosure, the AGENCY will release the requested information on the date specified.

The CONSULTANT agrees to notify the sub-consultant of any AGENCY communication regarding disclosure that may include a sub-consultant's proprietary and/or confidential information. The CONSULTANT notification to the sub-consultant will include the date that such records will be released by the AGENCY to the requester and state that unless the sub-consultant obtains a court order from a court of competent jurisdiction enjoining that disclosure the AGENCY will release the requested information. If the CONSULTANT and/or sub-consultant fail to obtain a court order or other judicial relief enjoining the AGENCY by the release date, the CONSULTANT shall waive and release and shall hold harmless and indemnify the AGENCY from all claims of actual or alleged damages, liabilities, or costs associated with the AGENCY's said disclosure of sub-consultants' information.

## **XX. Records Maintenance**

During the progress of the Work and SERVICES provided hereunder and for a period of not less than six (6) years from the date of final payment to the CONSULTANT, the CONSULTANT shall keep, retain, and maintain all "documents" pertaining to the SERVICES provided pursuant to this AGREEMENT. Copies of all "documents" pertaining to the SERVICES provided hereunder shall be made available for review at the CONSULTANT's place of business during normal working hours. If any litigation, claim, or audit is commenced, the CONSULTANT shall cooperate with AGENCY and assist in the production of all such documents. "Documents" shall be retained until all litigation, claims or audit findings have been resolved even though such litigation, claim, or audit continues past the six (6) year retention period.

For purposes of this AGREEMENT, "documents" means every writing or record of every type and description, including electronically stored information ("ESI"), that is in the possession, control, or custody of the CONSULTANT, including, without limitation, any and all correspondences, contracts, AGREEMENTS, appraisals, plans, designs, data, surveys, maps, spreadsheets, memoranda, stenographic or handwritten notes, reports, records, telegrams, schedules, diaries, notebooks, logbooks, invoices, accounting records, work sheets, charts, notes, drafts, scribbles, recordings, visual displays, photographs, minutes of meetings, tabulations, computations, summaries, inventories, and writings regarding conferences, conversations or telephone conversations, and any and all other taped, recorded, written, printed or typed matters of any kind or description; every copy of the foregoing whether or not the original is in the possession, custody, or control of the CONSULTANT, and every copy of any of the foregoing, whether or not such copy is a copy identical to an original, or whether or not such copy contains any commentary or notation whatsoever that does not appear on the original.

For purposes of this AGREEMENT, “ESI” means any and all computer data or electronic recorded media of any kind, including “Native Files”, that are stored in any medium from which it can be retrieved and examined, either directly or after translation into a reasonably useable form. ESI may include information and/or documentation stored in various software programs such as Email, Outlook, Word, Excel, Access, Publisher, PowerPoint, Adobe Acrobat, SQL databases, or any other software or electronic communication programs or databases that the CONSULTANT may use in the performance of its operations. ESI may be located on network servers, backup tapes, smart phones, thumb drives, CDs, DVDs, floppy disks, work computers, cell phones, laptops, or any other electronic device that CONSULTANT uses in the performance of its Work or SERVICES hereunder, including any personal devices used by the CONSULTANT or any sub-consultant at home.

“Native files” are a subset of ESI and refer to the electronic format of the application in which such ESI is normally created, viewed, and /or modified

The CONSULTANT shall include this section XX “Records Maintenance” in every subcontract it enters into in relation to this AGREEMENT and bind the sub-consultant to its terms, unless expressly agreed to otherwise in writing by the AGENCY prior to the execution of such subcontract.

In witness whereof, the parties hereto have executed this AGREEMENT as of the day and year shown in the “Execution Date” box on page one (1) of this AGREEMENT.

\_\_\_\_\_  
Signature

\_\_\_\_\_  
Date

\_\_\_\_\_  
Signature

\_\_\_\_\_  
Date

*Any modification, change, or reformation of this AGREEMENT shall require approval as to form by the Office of the Attorney General.*

***Exhibit A  
Scope of Work***

---

Project No. HSIP-000S(724)

See attached Scope of Work.



**Exhibit A**  
**Scope of Work**  
**Neighborhood Traffic Calming and Intersection Data Collection**  
**HSIP-000S(724)**  
**City of Sumner**

**Prepared For:** Thi Le, City of Sumner

**Prepared By:** George Hilen, SCJ Alliance

**Date Prepared:** February 26, 2026

### Overview

The City of Sumner is seeking to improve safety at several neighborhood intersections throughout the city. This project is a planning-phase study that will evaluate safety and mobility conditions at up to fifteen neighborhood intersections and corridors. The City's intent is to understand existing issues such as speeding, traffic operations, pedestrian conflicts, and roadway geometry, and to determine whether traffic calming measures or intersection improvements are appropriate. The ultimate goal is to identify potential solutions for each location and position the City to pursue grant funding or move forward with implementation using City funds.

SCJ Alliance will complete the engineering study to evaluate the following nine intersections (and up to six additional locations directed by the City) and determine what safety, operational, and traffic calming improvements are appropriate and feasible at each location. This will include data collection, analysis, and the development of recommendations that the City can use to prioritize projects and advance future funding and implementation efforts.

The following locations are included in this scope of work:

- Parker Road E and Meade McCumber Road E
- Parker Road E and Washington Street
- Cherry Avenue and Thompson Street
- North Street and Ryan Avenue
- Washington Street and Sumner Avenue
- McMillan Avenue and Washington Street
- McMillan Avenue and Everett Street
- Bonney Avenue in Washington Street
- Bonney Avenue and Everett Street

## Assumptions

- Funding for this project is provided by FHWA, via WSDOT, through the Highway Safety Improvement Program. Addition or changes of the funding sources may modify the requirements of the project and may result in an amendment to this scope of work.
- WSDOT's "Local Agency A&E Profession Services Negotiated Hour Rates Consultant Agreement" will be used for the Consultant Contract.
- Project duration will be for ten (10) months following execution of the scope of work, assuming completion by December 31, 2026.
- This project is a planning phase study and NEPA documentation will not be required.

## Phase 1 Management and Administration

### *Task 1 Management*

**Task 1.1 Management:** Manage the project by directing and supervising staff and reviewing work for the duration of the project. This management is for the overall work rather than specific tasks.

### *Task 2 Administration*

**Task 2.1 Progress Reports:** Prepare and submit a monthly progress report. Progress reports will show: (1) prior work performed, (2) current work planned, (3) schedule and budget status (including a 3-line earned value chart), (4) a summary of scope changes/added value, and (5) items needed from the CITY and/or others. Assume 10 progress reports.

**Task 2.2 Progress Billings:** Prepare a monthly progress invoice with progress reports attached. Invoices will show staff hours for each phase (i.e., Phase 1: Project Management).

### Assumptions

- Progress billing will be submitted monthly to the City

### *Task 3 Progress Meetings*

**Task 3.1 Progress Meetings:** The Consultant will host monthly virtual progress meetings. Assume two (2) CONSULTANT staff for ten (10) meetings.

## Phase 2 Traffic Calming Study

This phase evaluates current traffic conditions at each of the study locations and identifies key safety and operational issues. The work includes collecting and analyzing traffic, speed, crash, and roadway data, as well as documenting site characteristics. Findings from this phase will provide the foundation for developing and evaluating traffic calming alternatives in later phases.

### *Task 1 Existing Conditions*

#### **Task 1.1 Data Collection/Inventory**

**Site Visit:** Visit each study intersection and complete photo documentation of existing conditions. Assume two (2) Consultant staff present of one (1) site visit.

**Background Data:** Collect and review existing data for the project locations. This will include the City's Local Road Safety Plan, grant application, previous reports, City officials input, and similar documents.

**Traffic Count and Speed Data Coordination:** Coordinate data collection with the traffic count vendor for both turning movement counts and speed data collection at each of the 9 sites listed in the introduction. The cost for traffic counts is included as a reimbursable expense. The traffic counts will be collected for both the AM and PM peak hours. Speed data will be collected over a 3 day period.

**Crash Data:** Collect and review the most recent crash data for the project locations and analyze the crash types and severity.

### *Task 2 Baseline Conditions Analysis*

**Task 2.1 Traffic Volumes and Analysis:** Analyze the collected traffic volumes to determine consistency with roadways functional classification. Develop Synchro operational models for each project intersection. Conduct operational analysis for existing conditions during the AM and PM peak hours, as well as for AM and PM peak hours under future no-build conditions. The specific future analysis year will be determined by the City and provided to the Consultant.

**Task 2.2 Vehicle Speed Analysis:** Analyze the vehicle speed study results to identify locations where speeding is occurring and a concern.

**Task 2.3 Pedestrian Volumes and Conditions:** Analyze pedestrian conditions at each site to determine the accessibility for sidewalks and curb ramps. Analyze peak hour volumes at each location to determine if the crossing treatment type is appropriate. This will utilize the National Cooperative Highway Research Program (NCHRP) Report 562.

### *Task 3 Development and Evaluation of Alternatives*

**Task 3.1 Develop Traffic Calming Alternatives:** This task focuses on identifying potential traffic calming solutions for each of the locations based on the problems identified in the baseline conditions analysis. Alternatives will be developed at a conceptual level and will reflect both near-term and long-term implementation opportunities.

**Task 3.2 Evaluation of Alternatives:** This task evaluates each alternative to ensure recommendations are realistic, appropriate, and effective. The goal is to identify solutions that can be approved, constructed, and maintained while successfully addressing the identified problems. Evaluation will be based on things like feasibility, constructability, context sensitivity, effectiveness, and cost.

### *Task 4 Summary Report*

**Task 4.1 Draft Summary Report:** Prepare a draft summary report of the background information collected alternatives analysis results and recommendations. The conceptual figures and estimates established in Phase 3 will be included in the report.

**Task 4.2 Final Summary Report:** Following receipt of the City comments on the draft summary report, incorporate changes and provide a final summary report.

### **Deliverables**

- Draft summary report in PDF format via email, including supporting data, traffic counts, and speed data.
- Final summary report in PDF format via email.

## Phase 3 Conceptual Design and Cost Estimating

Work under this phase consists of developing conceptual layout of the potential solutions for the short and long term. A cost estimate will accompany each conceptual layout.

### *Task 1 Concept Design*

**Task 1.1 Short-Term Improvement Solutions:** Develop one (1) conceptual layout for short-term improvement per locations.

**Task 1.2 Long-Term Improvement Solutions:** Develop one (1) conceptual layout for long-term improvement per location.

### *Task 2 Cost Estimation*

**Task 2.1 Conceptual Level Estimate:** Develop conceptual level cost estimate for each conceptual layout.

#### Understanding

- Conceptual layouts will be produced using AutoCAD and will include aerial imaging and GIS information. Topographic survey will not be required. Conceptual layouts will be high level in order to produce conceptual cost estimates with 30% contingency/miscellaneous.
- Cost estimates will be produced using recent SJ bid tab information along with wash dot unit bid analysis.
- Cost estimates will be created using Bluebeam PDF markup tools.

#### Deliverables

- Conceptual layout exhibits in PDF format
- Conceptual cost estimates in PDF format

## Additional Services

The CITY may require additional services of the CONSULTANT. These services will be authorized under management reserve and/or a future contract amendment. The CONSULTANT shall provide a scope of work and a budget. The CONSULTANT shall not proceed with the work until the CITY has authorized the work and issued a notice to proceed.

**Exhibit B**  
**DBE Participation Plan**

---

In the absents of a mandatory DBE goal, a voluntary SBE goal amount of ten percent of the Consultant Agreement is established. The Consultant shall develop a SBE Participation Plan prior to commencing work. Although the goal is voluntary, the outreach efforts to provide SBE maximum practicable opportunities are not.

N/A

**Preparation and Delivery of Electronic Engineering and Other Data**

In this Exhibit the agency, as applicable, is to provide a description of the format and standards the consultant is to use in preparing electronic files for transmission to the agency. The format and standards to be provided may include, but are not limited to, the following:

I. Surveying, Roadway Design & Plans Preparation Section

A. Survey Data

See Exhibit A for Scope of Work in Exhibit A.

B. Roadway Design Files

See Exhibit A for Scope of Work in Exhibit A.

C. Computer Aided Drafting Files

See Exhibit A for Scope of Work in Exhibit A.

D. Specify the Agency's Right to Review Product with the Consultant

See Exhibit A for Scope of Work in Exhibit A.

E. Specify the Electronic Deliverables to Be Provided to the Agency

See Exhibit A for Scope of Work in Exhibit A.

F. Specify What Agency Furnished Services and Information Is to Be Provided

See Exhibit A for Scope of Work in Exhibit A.

II. Any Other Electronic Files to Be Provided

A copy of all electronic files will be provided to the City upon request.

III. Methods to Electronically Exchange Data

Email of FTP as approved by the City of Sumner.

A. Agency Software Suite

N/A

B. Electronic Messaging System

Email.

C. File Transfers Format

PDF, MS Word, Excel, and DWG files.

**Exhibit D**  
**Prime Consultant Cost Computations**

---

See attached Prime Consultant Cost Computation.

- Consultant Labor Hour Estimate
- Consultant ANTE Table
- ICR Letter

# Exhibit D

## [HSIP-000S(724)]

Consultant Labor Hour Estimate



**SCJ Alliance**

Client: City of Sumner

Template Version: 1/15/2026

Project: Neighborhood Traffic Calming and Intersection D

	LAG Contract								
Direct Labor	\$79.29	\$81.01	\$65.88	\$40.31	\$44.25	\$43.05	\$40.00		
OH (191.76%)	\$152.04	\$155.34	\$126.33	\$77.30	\$84.85	\$82.55	\$76.70		
Profit (20.0%)	\$15.86	\$16.20	\$13.18	\$8.06	\$8.85	\$8.61	\$8.00		
<b>Total</b>	<b>\$247.19</b>	<b>\$252.55</b>	<b>\$205.39</b>	<b>\$125.67</b>	<b>\$137.95</b>	<b>\$134.21</b>	<b>\$124.70</b>		

Job #: 25-000839

File Name: 2026-0226 Sumner Traffic Calming Fee Estimate.xlsm

Phase & Task No.	Phase & Task Title	Principal	Senior Consultant	PM2 Project Manager	E2 Engineer	E3 Engineer	Project Accountant	Graphic Designer	Total Direct Labor Hours & Cost	Total Cost
<b>PHASE 1 Management and Administration</b>										
<b>Task 1 Management</b>										
1	Management			30.0					30.0	\$ 6,161.39
Subtotal Hours:		0.0	0.0	30.0	0.0	0.0	0.0	0.0	30.0	\$ 6,161.39
<b>Task 2 Administration</b>										
1	Progress Reports			10.0					10.0	\$ 2,053.80
2	Progress Billings						10.0		10.0	\$ 1,342.13
Subtotal Hours:		0.0	0.0	10.0	0.0	0.0	10.0	0.0	20.0	\$ 3,395.92
<b>Task 3 Progress Meetings</b>										
1	Progress Meetings (assumes 10)			16.0					16.0	\$ 3,286.08
Subtotal Hours:		0.0	0.0	16.0	0.0	0.0	0.0	0.0	16.0	\$ 3,286.08
Total Phase Hours:		0.0	0.0	56.0	0.0	0.0	10.0	0.0	66.0	66.0
Total Phase Direct Labor:		\$0.00	\$0.00	\$3,689.14	\$0.00	\$0.00	\$430.50	\$0.00	\$4,119.64	\$ 12,843.39
<b>PHASE 2 Traffic Calming Study</b>										
<b>Task 1 Existing Conditions</b>										
1	Site Visits			12.0	12.0				24.0	\$ 3,972.60
2	Background Data			4.0	8.0				12.0	\$ 1,826.88
3	Traffic Count and Speed Coordination			4.0	8.0				12.0	\$ 1,826.88
4	Crash Data		2.0	4.0	10.0				16.0	\$ 2,583.34
Subtotal Hours:		0.0	2.0	24.0	38.0	0.0	0.0	0.0	64.0	\$ 10,209.70
<b>Task 2 Baseline Conditions Analysis</b>										
1	Traffic Volumes and Analysis		1.0	8.0	40.0				49.0	\$ 6,922.41
2	Vehicle Speed Analysis		1.0	8.0	30.0				39.0	\$ 5,665.71
3	Pedestrian Volumes and Conditions		1.0	4.0	24.0				29.0	\$ 4,090.17
Subtotal Hours:		0.0	3.0	20.0	94.0	0.0	0.0	0.0	117.0	\$ 16,678.29
<b>Task 3 Development and Evaluation of Alternatives</b>										
1	Develop Traffic Calming Alternatives		2.0	10.0	50.0				62.0	\$ 8,842.43
2	Evaluation of Alternatives		2.0	10.0	32.0				44.0	\$ 6,580.37
Subtotal Hours:		0.0	4.0	20.0	82.0	0.0	0.0	0.0	106.0	\$ 15,422.80
<b>Task 4 Summary Report</b>										
1	Draft Summary Report	2.0	4.0	30.0	48.0			8.0	92.0	\$ 14,695.79
2	Final Summary Report	1.0	2.0	16.0	24.0			4.0	47.0	\$ 7,553.28
Subtotal Hours:		3.0	6.0	46.0	72.0	0.0	0.0	12.0	139.0	\$ 22,249.07
Total Phase Hours:		3.0	15.0	110.0	286.0	0.0	0.0	12.0	426.0	\$ 426.0
Total Phase Direct Labor:		\$237.86	\$1,215.15	\$7,246.53	\$11,528.66	\$0.00	\$0.00	\$480.00	\$20,708.19	\$ 64,559.86

# Exhibit D

## [HSIP-000S(724)]

Consultant Labor Hour Estimate



**SCJ Alliance**

Client: City of Sumner

Template Version: 1/15/2026

Project: Neighborhood Traffic Calming and Intersection D

LAG Contract

Job #: 25-000839

File Name: 2026-0226 Sumner Traffic Calming Fee Estimate.xlsm

Phase & Task No.	Phase & Task Title	Principal	Senior Consultant	PM2 Project Manager	E2 Engineer	E3 Engineer	Project Accountant	Graphic Designer	Total Direct Labor Hours & Cost	Total Cost
<b>PHASE 3 Conceptual Design and Cost Estimating</b>										
<b>Task 1 Concept Design</b>										
1	Short Term Improvement Solutions	2.0		12.0		60.0		14.0	88.0	\$ 12,982.00
2	Long-Term Improvement Solutions	2.0		12.0		120.0		20.0	154.0	\$ 22,007.45
Subtotal Hours:		4.0	0.0	24.0	0.0	180.0	0.0	34.0	242.0	\$ 34,989.45
<b>Task 2 Cost Estimation</b>										
1	Conceptual Level Estimate			10.0		56.0			66.0	\$ 9,779.21
Subtotal Hours:		0.0	0.0	10.0	0.0	56.0	0.0	0.0	66.0	\$ 9,779.21
Total Phase Hours:		4.0	0.0	34.0	0.0	236.0	0.0	34.0	308.0	\$ 308.0
Total Phase Direct Labor:		\$317.14	\$0.00	\$2,239.84	\$0.00	\$10,443.00	\$0.00	\$1,360.00	\$14,359.98	\$ 44,768.66
Total Hours All Phases		7.0	15.0	200.0	286.0	236.0	10.0	46.0	800.0	800.0
Total Direct Labor Estimate All Phases		\$555.00	\$1,215.15	\$13,175.50	\$11,528.66	\$10,443.00	\$430.50	\$1,840.00	\$39,187.81	\$ 122,171.91
<b>Indirect Costs</b>										
Subconsultants:										
										\$ -
Subconsultant Subtotal:										\$ -
Subconsultant Markup:										\$ -
<b>Subconsultant Total:</b>										<b>\$ -</b>
Reimbursable Expenses:										
										\$ -
Copies, Printing, etc.										\$ 5,000.00
Traffic Counts										\$ 217.50
Mileage (300 miles @ \$0.725 per mile)										\$ 5,217.50
Expenses Subtotal:										\$ -
Expenses Markup:										\$ -
<b>Expenses Total:</b>										<b>\$ 5,217.50</b>
Management Reserve:										\$ -
<b>Total Indirect Costs:</b>										<b>\$ 5,217.50</b>
<b>Total:</b>										<b>\$ 127,389.41</b>

# Exhibit D

## [HSIP-000S(724)]



**SCJ Alliance**

**Client:** City of Sumner  
**Project:** Neighborhood Traffic Calming and Intersection Da  
**Job #:** 25-000839  
**File Name:** 2026-0226 Sumner Traffic Calming Fee Estimate.xlsm  
**Date:** 1/23/26

Hourly Rate Table Format: LAG Contract  
 Allowable Overhead Rate: 191.76%  
 Profit: 20.00%  
 Billing Rate Table Version: 1/15/2026

**Actuals Not To Exceed Billing Rate Table (ANTE)**

Job Classifications	Direct Labor Hourly Rate NTE	Allowable Overhead 191.76%	Negotiated Profit 20.00%	Total Hourly Billing Rates NTE
Principal	\$140.20	\$268.85	\$28.04	\$437.09
Senior Consultant	\$112.37	\$215.47	\$22.47	\$350.31
Senior Project Manager	\$100.56	\$192.84	\$20.11	\$313.51
PM3 Project Manager	\$83.28	\$159.69	\$16.66	\$259.62
PM2 Project Manager	\$80.14	\$153.68	\$16.03	\$249.85
PM1 Project Manager	\$64.90	\$124.45	\$12.98	\$202.33
Senior Engineer	\$70.20	\$134.62	\$14.04	\$218.87
E4 Engineer	\$66.78	\$128.06	\$13.36	\$208.19
E3 Engineer	\$60.13	\$115.30	\$12.03	\$187.46
E2 Engineer	\$52.48	\$100.63	\$10.50	\$163.61
E1 Engineer	\$43.54	\$83.49	\$8.71	\$135.74
Senior Landscape Architect	\$66.83	\$128.15	\$13.37	\$208.34
L4 Landscape	\$56.86	\$109.04	\$11.37	\$177.27
L3 Landscape	\$49.13	\$94.21	\$9.83	\$153.17
L2 Landscape	\$44.07	\$84.51	\$8.81	\$137.40
L1 Landscape	\$37.12	\$71.18	\$7.42	\$115.73
Senior Planner	\$79.78	\$152.98	\$15.96	\$248.71
P4 Planner	\$55.89	\$107.17	\$11.18	\$174.24
P3 Planner	\$50.56	\$96.96	\$10.11	\$157.63
P2 Planner	\$42.70	\$81.88	\$8.54	\$133.11
P1 Planner	\$39.63	\$76.00	\$7.93	\$123.56
Senior Technician	\$60.11	\$115.27	\$12.02	\$187.41
T4 Technician	\$52.19	\$100.08	\$10.44	\$162.71
T3 Technician	\$44.35	\$85.04	\$8.87	\$138.25
T2 Technician	\$40.45	\$77.57	\$8.09	\$126.11
T1 Technician	\$35.37	\$67.83	\$7.07	\$110.27
Construction Inspector	\$35.87	\$68.79	\$7.17	\$111.84
Senior Construction Manager	\$0.00	\$0.00	\$0.00	\$0.00
RE 3 Construction Resident Engineer	\$0.00	\$0.00	\$0.00	\$0.00
RE 2 Construction Resident Engineer	\$0.00	\$0.00	\$0.00	\$0.00
RE 1 Construction Resident Engineer	\$0.00	\$0.00	\$0.00	\$0.00
Construction Office Engineer	\$0.00	\$0.00	\$0.00	\$0.00
CI4 Construction Inspector	\$0.00	\$0.00	\$0.00	\$0.00
CI3 Construction Inspector	\$0.00	\$0.00	\$0.00	\$0.00
CI2 Construction Inspector	\$0.00	\$0.00	\$0.00	\$0.00
CI1 Construction Inspector	\$0.00	\$0.00	\$0.00	\$0.00
Graphic Designer	\$51.69	\$99.11	\$10.34	\$161.14
PC3 Project Coordinator - CM Only	\$0.00	\$0.00	\$0.00	\$0.00
PC2 Project Coordinator	\$49.59	\$95.09	\$9.92	\$154.59
PC1 Project Coordinator	\$40.46	\$77.58	\$8.09	\$126.13
Project Accountant	\$67.98	\$130.36	\$13.60	\$211.93
IT Specialist	\$64.64	\$123.95	\$12.93	\$201.51
Senior Marketing Coordinator	\$63.44	\$121.65	\$12.69	\$197.78
Marketing Coordinator	\$44.80	\$85.90	\$8.96	\$139.66
Communications Manager	\$61.64	\$118.21	\$12.33	\$192.18
Information Services Manager	\$79.51	\$152.47	\$15.90	\$247.89

Exhibit D  
[HSIP-000S(724)]



Development Division  
Contract Services Office  
PO Box 47408  
Olympia, WA 98504-7408  
7345 Linderson Way SW  
Tumwater, WA 98501-6504

TTY: 1-800-833-6388  
[www.wsdot.wa.gov](http://www.wsdot.wa.gov)

June 30, 2025

Shea, Carr & Jewell, Inc., DBA SCJ Alliance  
8760 Tallon Ln NE, Suite 200  
Lacey, WA 98513

Subject: Acceptance FYE 2024 ICR – CPA Report

Dear Tammy McDonald:

We have accepted your firm's FYE 2024 Indirect Cost Rate (ICR) of 191.76% of direct labor (rate includes 0.43% Facilities Capital Cost of Money) based on the "Independent CPA Report" prepared by Stambaugh Ness, Inc. related to the Shea, Carr & Jewell, Inc., DBA SCJ Alliance. This rate will be applicable for WSDOT Agreements and Local Agency Contracts in Washington only. This rate may be subject to additional review if considered necessary by WSDOT. Your ICR must be updated on an annual basis.

Costs billed to agreements/contracts will still be subject to audit of actual costs, based on the terms and conditions of the respective agreement/contract.

This was not a cognizant review. Any other entity contracting with the firm is responsible for determining the acceptability of the ICR.

If you have any questions, feel free to contact our office at **(360) 704-6397** or via email [consultanrates@wsdot.wa.gov](mailto:consultanrates@wsdot.wa.gov).

Regards,

  
[Schatzie Harvey \(Jun 30, 2025 12:53 PM\)](#)  
SCHATZIE HARVEY, CPA  
Contract Services Manager

SH: kb

**Exhibit D**  
[HSIP-000S(724)]

**Fee Calculator per WSDOT Consultant Services Manual,  
Appendix AA**

<b>Size of Job:</b>	\$129,822
<b>Duration:</b>	10 months
<b>Subs:</b>	0%

**Weighted Guidelines**

<b>Factor</b>	<b>Rate</b> (per App AA)	<b>Weight</b> (calc'd, 0.15 to 0.30)	<b>Value</b> (Rate*Weight)
Degree of Risk	25	0.150	3.75
Relative Difficulty of Work	20	0.150	3.00
Size of Job	15	0.300	4.50
Period of Performance	15	0.200	3.00
Assistance by the Client	15	0.280	4.20
Subconsulting	10	0.15	1.50
<b>Total:</b>			19.95
<b>Proposed Fee Percentage:</b>			<b>20.0%</b>

**Exhibit E**  
**Sub-consultant Cost Computations**

---

If no sub-consultant participation listed at this time. The CONSULTANT shall not sub-contract for the performance of any work under this AGREEMENT without prior written permission of the AGENCY. Refer to section VI “Sub-Contracting” of this AGREEMENT.

N/A

# **Exhibit F - Title VI Assurances Appendix A & E**

## **APPENDIX A**

During the performance of this contract, the contractor, for itself, its assignees, and successors in interest (hereinafter referred to as the "contractor") agrees as follows:

1. **Compliance with Regulations:** The contractor (hereinafter includes consultants) will comply with the Acts and the Regulations relative to Non-discrimination in Federally-assisted programs of the U.S. Department of Transportation, (*Federal Highway Administration*), as they may be amended from time to time, which are herein incorporated by reference and made a part of this contract.
2. **Non-discrimination:** The contractor, with regard to the work performed by it during the contract, will not discriminate on the grounds of race, color, or national origin in the selection and retention of subcontractors, including procurements of materials and leases of equipment. The contractor will not participate directly or indirectly in the discrimination prohibited by the Acts and the Regulations, including employment practices when the contract covers any activity, project, or program set forth in Appendix B of 49 CFR Part 21. *[Include Washington State Department of Transportation specific program requirements.]*
3. **Solicitations for Subcontracts, Including Procurements of Materials and Equipment:** In all solicitations, either by competitive bidding, or negotiation made by the contractor for work to be performed under a subcontract, including procurements of materials, or leases of equipment, each potential subcontractor or supplier will be notified by the contractor of the contractor's obligations under this contract and the Acts and the Regulations relative to Non-discrimination on the grounds of race, color, or national origin. *[Include Washington State Department of Transportation specific program requirements.]*
4. **Information and Reports:** The contractor will provide all information and reports required by the Acts, the Regulations, and directives issued pursuant thereto and will permit access to its books, records, accounts, other sources of information, and its facilities as may be determined by the Recipient or the (*Federal Highway Administration*) to be pertinent to ascertain compliance with such Acts, Regulations, and instructions. Where any information required of a contractor is in the exclusive possession of another who fails or refuses to furnish the information, the contractor will so certify to the Recipient or the (*Federal Highway Administration*), as appropriate, and will set forth what efforts it has made to obtain the information.
5. **Sanctions for Noncompliance:** In the event of a contractor's noncompliance with the Non- discrimination provisions of this contract, the Recipient will impose such contract sanctions as it or the (*Federal Highway Administration*) may determine to be appropriate, including, but not limited to:
  - a. withholding payments to the contractor under the contract until the contractor complies; and/or
  - b. cancelling, terminating, or suspending a contract, in whole or in part.
6. **Incorporation of Provisions:** The contractor will include the provisions of paragraphs one through six in every subcontract, including procurements of materials and leases of equipment, unless exempt by the Acts, the Regulations and directives issued pursuant thereto. The contractor will take action with respect to any subcontract or procurement as the Recipient or the (*Federal Highway Administration*) may direct as a means of enforcing such provisions including sanctions for noncompliance. Provided, that if the contractor becomes involved in, or is threatened with litigation by a subcontractor, or supplier because of such direction, the contractor may request the Recipient to enter into any litigation to protect the interests of the Recipient. In addition, the contractor may request the United States to enter into the litigation to protect the interests of the United States.

# **Exhibit F - Title VI Assurances Appendix A & E**

---

## APPENDIX E

During the performance of this contract, the contractor, for itself, its assignees, and successors in interest (hereinafter referred to as the "contractor") agrees to comply with the following non-discrimination statutes and authorities; including but not limited to:

### **Pertinent Non-Discrimination Authorities:**

- Title VI of the Civil Rights Act of 1964 (42 U.S.C. § 2000d et seq., 78 stat. 252), (prohibits discrimination on the basis of race, color, national origin); and 49 CFR Part 21.
- The Uniform Relocation Assistance and Real Property Acquisition Policies Act of 1970, (42 U.S.C. § 4601), (prohibits unfair treatment of persons displaced or whose property has been acquired because of Federal or Federal-aid programs and projects);
- Federal-Aid Highway Act of 1973, (23 U.S.C. § 324 et seq.), (prohibits discrimination on the basis of sex);
- Section 504 of the Rehabilitation Act of 1973, (29 U.S.C. § 794 et seq.), as amended, (prohibits discrimination on the basis of disability); and 49 CFR Part 27;
- The Age Discrimination Act of 1975, as amended, (42 U.S.C. § 6101 et seq.), (prohibits discrimination on the basis of age);
- Airport and Airway Improvement Act of 1982, (49 USC § 471, Section 47123), as amended, (prohibits discrimination based on race, creed, color, national origin, or sex);
- The Civil Rights Restoration Act of 1987, (PL 100-209), (Broadened the scope, coverage and applicability of Title VI of the Civil Rights Act of 1964, The Age Discrimination Act of 1975 and Section 504 of the Rehabilitation Act of 1973, by expanding the definition of the terms "programs or activities" to include all of the programs or activities of the Federal-aid recipients, sub-recipients and contractors, whether such programs or activities are Federally funded or not);
- Titles II and III of the Americans with Disabilities Act, which prohibit discrimination on the basis of disability in the operation of public entities, public and private transportation systems, places of public accommodation, and certain testing entities (42 U.S.C. §§ 12131-12189) as implemented by Department of Transportation regulations at 49 C.F.R. parts 37 and 38;
- The Federal Aviation Administration's Non-discrimination statute (49 U.S.C. § 47123) (prohibits discrimination on the basis of race, color, national origin, and sex);
- Executive Order 12898, Federal Actions to Address Environmental Justice in Minority Populations and Low-Income Populations, which ensures discrimination against minority populations by discouraging programs, policies, and activities with disproportionately high and adverse human health or environmental effects on minority and low-income populations;
- Executive Order 13166, Improving Access to Services for Persons with Limited English Proficiency, and resulting agency guidance, national origin discrimination includes discrimination because of limited English proficiency (LEP). To ensure compliance with Title VI, you must take reasonable steps to ensure that LEP persons have meaningful access to your programs (70 Fed. Reg. at 74087 to 74100);
- Title IX of the Education Amendments of 1972, as amended, which prohibits you from discriminating because of sex in education programs or activities (20 U.S.C. 1681 et seq).

# **Exhibit G**

## **Certification Document**

---

- Exhibit G-1(a) Certification of Consultant
- Exhibit G-1(b) Certification of \_\_\_\_\_
- Exhibit G-2 Certification Regarding Debarment, Suspension and Other Responsibility Matters - Primary Covered Transactions
- Exhibit G-3 Certification Regarding the Restrictions of the Use of Federal Funds for Lobbying
- Exhibit G-4 Certificate of Current Cost or Pricing Data

## Exhibit G-1(a) Certification of Consultant

I hereby certify that I am the and duly authorized representative of the firm of

\_\_\_\_\_

whose address is

\_\_\_\_\_

and that neither the above firm nor I have

- a) Employed or retained for a commission, percentage, brokerage, contingent fee, or other consideration, any firm or person (other than a bona fide employee working solely for me or the above CONSULTANT) to solicit or secure this AGREEMENT;
- b) Agreed, as an express or implied condition for obtaining this contract, to employ or retain the services of any firm or person in connection with carrying out this AGREEMENT; or
- c) Paid, or agreed to pay, to any firm, organization or person (other than a bona fide employee working solely for me or the above CONSULTANT) any fee, contribution, donation, or consideration of any kind for, or in connection with, procuring or carrying out this AGREEMENT; except as hereby expressly stated (if any);

I acknowledge that this certificate is to be furnished to the \_\_\_\_\_

and the Federal Highway Administration, U.S. Department of Transportation in connection with this AGREEMENT involving participation of Federal-aid highway funds, and is subject to applicable State and Federal laws, both criminal and civil.

\_\_\_\_\_  
Consultant (Firm Name)

\_\_\_\_\_  
Signature (Authorized Official of Consultant)

\_\_\_\_\_  
Date

**Exhibit G-1(b) Certification of \_\_\_\_\_**

I hereby certify that I am the:

Authorized Official

Other

of the \_\_\_\_\_, and \_\_\_\_\_

or its representative has not been required, directly or indirectly as an express or implied condition in connection with obtaining or carrying out this AGREEMENT to:

- a) Employ or retain, or agree to employ to retain, any firm or person; o
- b) Pay, or agree to pay, to any firm, person, or organization, any fee, contribution, donation, or consideration of any kind; except as hereby expressly stated (if any):

I acknowledge that this certificate is to be furnished to the \_\_\_\_\_

and the Federal Highway Administration, U.S. Department of Transportation, in connection with this AGREEMENT involving participation of Federal-aid highway funds, and is subject to applicable State and Federal laws, both criminal and civil.

\_\_\_\_\_  
Signature

\_\_\_\_\_  
Date

## Exhibit G-2 Certification Regarding Debarment Suspension and Other Responsibility Matters - Primary Covered Transactions

- I. The prospective primary participant certifies to the best of its knowledge and belief, that it and its principals:
  - A. Are not presently debarred, suspended, proposed for debarment, declared ineligible, or voluntarily excluded from covered transactions by any Federal department or agency;
  - B. Have not within a three (3) year period preceding this proposal been convicted of or had a civil judgment rendered against them for commission of fraud or a criminal offense in connection with obtaining, attempting to obtain, or performing a public (Federal, State, or local) transaction or contract under a public transaction; violation of Federal or State anti-trust statues or commission of embezzlement, theft, forgery, bribery, falsification or destruction of records, making false statements, or receiving stolen property;
  - C. Are not presently indicted for or otherwise criminally or civilly charged by a governmental entity (Federal, State, or local) with commission of any of the offenses enumerated in paragraph (1)(b) of this certification; an
  - D. Have not within a three (3) year period preceding this application / proposal had one or more public transactions (Federal, State and local) terminated for cause or default.
- II. Where the prospective primary participant is unable to certify to any of the statements in this certification such prospective participant shall attach an explanation to this proposal.

---

Consultant (Firm Name)

---

Signature (Authorized Official of Consultant)

---

Date

## Exhibit G-3 Certification Regarding the Restrictions of the Use of Federal Funds for Lobbying

The prospective participant certifies, by signing and submitting this bid or proposal, to the best of his or her knowledge and belief, that:

1. No Federal appropriated funds have been paid or will be paid, by or on behalf of the undersigned, to any person for influencing or attempting to influence an officer or employee of any Federal agency, a Member of Congress, an officer or employee of Congress, or any employee of a Member of Congress in connection with the awarding of any Federal contract, the making of any Federal grant, the making of any Federal loan, the entering into of any cooperative AGREEMENT, and the extension, continuation, renewal, amendment, or modification of Federal contract, grant, loan or cooperative AGREEMENT.
2. If any funds other than Federal appropriated funds have been paid or will be paid to any person for influencing or attempting to influence an officer or employee of any Federal agency, a Member of Congress, an officer or employee of Congress, or an employee of a Member of Congress in connection with this Federal contract, grant, loan or cooperative AGREEMENT, the undersigned shall complete and submit Standard Form - LLL, "Disclosure Form to Report Lobbying," in accordance with its instructions.

This certification is a material representation of fact upon which reliance was placed when this transaction was made or entered into. Submission of this certification is a prerequisite for making or entering into this transaction imposed by Section 1352, Title 31, U.S. Code. Any person who fails to file the require certification shall be subject to a civil penalty of not less than \$10,000.00, and not more than \$100,000.00 for each such failure.

The prospective participant also agrees by submitting his or her bid or proposal that he or she shall require that the language of this certification be included in all lower tier sub-contracts, which exceed \$100,000 and that all such sub-recipients shall certify and disclose accordingly.

---

Consultant (Firm Name)

---

Signature (Authorized Official of Consultant)

---

Date

## Exhibit G-4 Certification of Current Cost or Pricing Data

This is to certify that, to the best of my knowledge and belief, the cost or pricing data (as defined in section of the Federal Acquisition Regulation (FAR) and required under FAR subsection 15.403-4) submitted, either actually or by specific identification in writing, to the Contracting Officer or to the Contracting Officer's representative in support of \_\_\_\_\_\* are accurate, complete, and current as of \_\_\_\_\_\*\*.

This certification includes the cost or pricing data supporting any advance AGREEMENT's and forward pricing rate AGREEMENT's between the offer or and the Government that are part of the proposal.

Firm: \_\_\_\_\_

\_\_\_\_\_  
Signature

\_\_\_\_\_  
Title

Date of Execution \_\_\_\_\_\*\*\*.

\_\_\_\_\_  
\*Identify the proposal, quotation, request for pricing adjustment, or other submission involved, giving the appropriate identifying number (e.g. project title.)

\*\*Insert the day, month, and year, when price negotiations were concluded and price AGREEMENT was reached.

\*\*\*Insert the day, month, and year, of signing, which should be as close as practicable to the date when the price negotiations were concluded and the contract price was agreed to.

# **Exhibit H**

## **Liability Insurance Increase**

---

### **To Be Used Only If Insurance Requirements Are Increased**

The professional liability limit of the CONSULTANT to the AGENCY identified in Section XII, Legal Relations and Insurance of this Agreement is amended to \$ \_\_\_\_\_ .

The CONSULTANT shall provide Professional Liability insurance with minimum per occurrence limits in the amount of \$ \_\_\_\_\_.

Such insurance coverage shall be evidenced by one of the following methods:

- Certificate of Insurance
- Self-insurance through an irrevocable Letter of Credit from a qualified financial institution

Self-insurance through documentation of a separate fund established exclusively for the payment of professional liability claims, including claim amounts already reserved against the fund, safeguards established for payment from the fund, a copy of the latest annual financial statements, and disclosure of the investment portfolio for those funds.

Should the minimum Professional Liability insurance limit required by the AGENCY as specified above exceed \$1 million per occurrence or the value of the contract, whichever is greater, then justification shall be submitted to the Federal Highway Administration (FHWA) for approval to increase the minimum insurance limit.

If FHWA approval is obtained, the AGENCY may, at its own cost, reimburse the CONSULTANT for the additional professional liability insurance required.

Notes: Cost of added insurance requirements: \$ \_\_\_\_\_.

- Include all costs, fee increase, premiums.
  - This cost shall not be billed against an FHWA funded project.
  - For final contracts, include this exhibit
-

# **Exhibit I**

## **Alleged Consultant Design Error Procedures**

---

The purpose of this exhibit is to establish a procedure to determine if a consultant has alleged design error is of a nature that exceeds the accepted standard of care. In addition, it will establish a uniform method for the resolution and/or cost recovery procedures in those instances where the agency believes it has suffered some material damage due to the alleged error by the consultant.

### **Step 1 Potential Consultant Design Error(s) is Identified by Agency's Project Manager**

At the first indication of potential consultant design error(s), the first step in the process is for the Agency's project manager to notify the Director of Public Works or Agency Engineer regarding the potential design error(s). For federally funded projects, the Region Local Programs Engineer should be informed and involved in these procedures. (Note: The Director of Public Works or Agency Engineer may appoint an agency staff person other than the project manager, who has not been as directly involved in the project, to be responsible for the remaining steps in these procedures.)

### **Step 2 Project Manager Documents the Alleged Consultant Design Error(s)**

After discussion of the alleged design error(s) and the magnitude of the alleged error(s), and with the Director of Public Works or Agency Engineer's concurrence, the project manager obtains more detailed documentation than is normally required on the project. Examples include all decisions and descriptions of work, photographs, records of labor, materials, and equipment.

### **Step 3 Contact the Consultant Regarding the Alleged Design Error(s)**

If it is determined that there is a need to proceed further, the next step in the process is for the project manager to contact the consultant regarding the alleged design error(s) and the magnitude of the alleged error(s). The project manager and other appropriate agency staff should represent the agency and the consultant should be represented by their project manager and any personnel (including sub-consultants) deemed appropriate for the alleged design error(s) issue.

### **Step 4 Attempt to Resolve Alleged Design Error with Consultant**

After the meeting(s) with the consultant have been completed regarding the consultant's alleged design error(s), there are three possible scenarios:

- It is determined via mutual agreement that there is not a consultant design error(s). If this is the case, then the process will not proceed beyond this point.
- It is determined via mutual agreement that a consultant design error(s) occurred. If this is the case, then the Director of Public Works or Agency Engineer, or their representatives, negotiate a settlement with the consultant. The settlement would be paid to the agency or the amount would be reduced from the consultant's agreement with the agency for the services on the project in which the design error took place. The agency is to provide LP, through the Region Local Programs Engineer, a summary of the settlement for review and to make adjustments, if any, as to how the settlement affects federal reimbursements. No further action is required.
- There is not a mutual agreement regarding the alleged consultant design error(s). The consultant may request that the alleged design error(s) issue be forwarded to the Director of Public Works or Agency Engineer for review. If the Director of Public Works or Agency Engineer, after review with their legal counsel, is not able to reach mutual agreement with the consultant, proceed to Step 5.

## **Step 5 Forward Documents to Local Programs**

For federally funded projects, all available information, including costs, should be forwarded through the Region Local Programs Engineer to LP for their review and consultation with the FHWA. LP will meet with representatives of the agency and the consultant to review the alleged design error(s), and attempt to find a resolution to the issue. If necessary, LP will request assistance from the Attorney General's Office for legal interpretation. LP will also identify how the alleged error(s) affects eligibility of project costs for federal reimbursement.

- If mutual agreement is reached, the agency and consultant adjust the scope of work and costs to reflect the agreed upon resolution. LP, in consultation with FHWA, will identify the amount of federal participation in the agreed upon resolution of the issue.
- If mutual agreement is not reached, the agency and consultant may seek settlement by arbitration or by litigation.

# *Exhibit J*

## **Consultant Claim Procedures**

---

The purpose of this exhibit is to describe a procedure regarding claim(s) on a consultant agreement. The following procedures should only be utilized on consultant claims greater than \$1,000. If the consultant's claim(s) total a \$1,000 or less, it would not be cost effective to proceed through the outlined steps. It is suggested that the Director of Public Works or Agency Engineer negotiate a fair and reasonable price for the consultant's claim(s) that total \$1,000 or less.

This exhibit will outline the procedures to be followed by the consultant and the agency to consider a potential claim by the consultant.

### **Step 1 Consultant Files a Claim with the Agency Project Manager**

If the consultant determines that they were requested to perform additional services that were outside of the agreement's scope of work, they may be entitled to a claim. The first step that must be completed is the request for consideration of the claim to the Agency's project manager.

The consultant's claim must outline the following:

- Summation of hours by classification for each firm that is included in the claim
- Any correspondence that directed the consultant to perform the additional work;
- Timeframe of the additional work that was outside of the project scope;
- Summary of direct labor dollars, overhead costs, profit and reimbursable costs associated with the additional work; and
- Explanation as to why the consultant believes the additional work was outside of the agreement scope of work.

### **Step 2 Review by Agency Personnel Regarding the Consultant's Claim for Additional Compensation**

After the consultant has completed step 1, the next step in the process is to forward the request to the Agency's project manager. The project manager will review the consultant's claim and will meet with the Director of Public Works or Agency Engineer to determine if the Agency agrees with the claim. If the FHWA is participating in the project's funding, forward a copy of the consultant's claim and the Agency's recommendation for federal participation in the claim to the WSDOT Local Programs through the Region Local Programs Engineer. If the claim is not eligible for federal participation, payment will need to be from agency funds.

If the Agency project manager, Director of Public Works or Agency Engineer, WSDOT Local Programs (if applicable), and FHWA (if applicable) agree with the consultant's claim, send a request memo, including backup documentation to the consultant to either supplement the agreement, or create a new agreement for the claim. After the request has been approved, the Agency shall write the supplement and/or new agreement and pay the consultant the amount of the claim. Inform the consultant that the final payment for the agreement is subject to audit. No further action is needed regarding the claim procedures.

If the Agency does not agree with the consultant's claim, proceed to step 3 of the procedures.

### **Step 3 Preparation of Support Documentation Regarding Consultant's Claim(s)**

If the Agency does not agree with the consultant's claim, the project manager shall prepare a summary for the Director of Public Works or Agency Engineer that included the following:

- Copy of information supplied by the consultant regarding the claim;
- Agency's summation of hours by classification for each firm that should be included in the claim
- Any correspondence that directed the consultant to perform the additional work;
- Agency's summary of direct labor dollars, overhead costs, profit and reimbursable costs associate with the additional work;
- Explanation regarding those areas in which the Agency does/does not agree with the consultant's claim(s);
- Explanation to describe what has been instituted to preclude future consultant claim(s); and
- Recommendations to resolve the claim.

### **Step 4 Director of Public Works or Agency Engineer Reviews Consultant Claim and Agency Documentation**

The Director of Public Works or Agency Engineer shall review and administratively approve or disapprove the claim, or portions thereof, which may include getting Agency Council or Commission approval (as appropriate to agency dispute resolution procedures). If the project involves federal participation, obtain concurrence from WSDOT Local Programs and FHWA regarding final settlement of the claim. If the claim is not eligible for federal participation, payment will need to be from agency funds.

### **Step 5 Informing Consultant of Decision Regarding the Claim**

The Director of Public Works or Agency Engineer shall notify (in writing) the consultant of their final decision regarding the consultant's claim(s). Include the final dollar amount of the accepted claim(s) and rationale utilized for the decision.

### **Step 6 Preparation of Supplement or New Agreement for the Consultant's Claim(s)**

The agency shall write the supplement and/or new agreement and pay the consultant the amount of the claim. Inform the consultant that the final payment for the agreement is subject to audit

---

**SUBJECT:** 63rd Street Storm Improvements Project Change Order #2

**CATEGORY:** Consent

---

**BUDGET IMPACT:**

Expenditure Required: \$73,552.64

Within Budget Allocation: Yes

---

**ATTACHMENTS:**

1. 63rd Street Storm Improvements Project Change Order #2

**STAFF CONTACT:** Courtney Littrell, Assistant Engineering Manager

---

**SUMMARY BACKGROUND:**

The 63rd Street Storm Improvements project consists of installing a storm main along 63rd Street Court East and installing catch basins within the existing curb line.

This change order adds additional sidewalk, driveway, curb and gutter, and pavement replacement. These additional replacements were due to existing conditions not aligning correctly with ADA compliance and increased deterioration. The original contract amount with previous change orders was \$201,351.41 and the change order adds \$73,552.64 for a total contract cost of \$274,904.05.

---

**COUNCIL COMMITTEE/STUDY SESSION:** Public Works Committee

**MEETING/STUDY SESSION DATE:** 4/21/2026

**COMMITTEE RECOMMENDATION:** Do Pass

**STAFF RECOMMENDATIONS/MOTION:**

A motion approving a supplement to Sascon, LLC Construction Contract for the 63rd Street Storm Improvements Project (CIP 21-21), increasing the contract amount by \$73,552.64 to a total authorized amount not-to-exceed \$274,904.05, and authorizing the Mayor and City Administrator to execute any and all documents necessary to effectuate the amendment, substantially in a form as approved by the City Attorney.



## **CHANGE ORDER NO. 02: Additional Driveway, Sidewalks, and Asphalt**

NAME OF CONTRACTOR, CONSULTANT, OR VENDOR: Sascon, LLC (“Contractor”)

CONTRACT NAME & PROJECT NUMBER: 63<sup>rd</sup> St Storm Improvements (CIP 21-21)

ORIGINAL CONTRACT DATE: October 7, 2025

This Change Order amends the above-referenced contract; all other provisions of the contract that are not inconsistent with this Change Order shall remain in effect. For valuable consideration and by mutual consent of the parties, the project contract is modified as follows:

**1.** Section I of the Agreement, is hereby modified as follows:

New Pay Item CO02-1, “Sidewalk Removal, Regrade, and Repour, LS” is added at a lump sum price of \$16,043.34 to the contract to compensate the Contractor for additional costs associated with the removal, regrading, and repouring of sidewalks within the project limits.

New Pay Item CO02-2, “Additional Driveway, SY” is added at a square yard price of \$185.00, for a total of 66.79 square yards, to the contract to compensate the Contractor for additional costs associated with pouring additional driveway at 15613 63<sup>rd</sup> St Ct E.

New Pay Item CO02-3, “Additional Sidewalk, SY” is added at a square yard price of \$255.00, for a total of 20.01 square yards, to the contract to compensate the Contractor for additional costs associated with pouring additional sidewalks at 15613 63<sup>rd</sup> St Ct E.

New Pay item CO02-4, “Additional Curb and Gutter, LF” is added at a lineal foot price of \$65.00, for a total of 234 lineal feet, to the contract to compensate the Contractor for additional costs associated with placing additional curb and gutter within the project limits.

New Pay Item CO02-5, “Additional Asphalt, TON” is added at a tonnage price of \$285.00, for a total of 87.16 tons, to the contract to compensate the Contractor for additional costs associated with paving additional HMA Pavement throughout the project limits.

**CHANGE ORDER 02: Additional Driveway, Sidewalk, and Asphalt**

2. The contract amount and time for performance provisions of are hereby modified as follows:

Current Change Order	<b>\$73,552.64</b>
Applicable WSST Tax on this Change Order	<b>\$0.00</b>
Days Required ± for this Change Order	<b>0 working days</b>

The Contractor accepts all requirements of this Change Order by signing below. Also, pursuant to the above-referenced contract, Contractor agrees to waive any protest it may have regarding this Change Order and acknowledges and accepts that this Change Order constitutes final settlement of all claims of any kind or nature arising from or connected with any work either covered or affected by this Change Order, including, without limitation, claims related to contract time, contract acceleration, onsite or home office overhead, or lost profits.

The parties whose names appear below swear under penalty of perjury that they are authorized to enter into this contract modification, which is binding on the parties of this contract.

3. The Contractor will adjust the amount of its performance bond (if any) for this project to be consistent with the revised contract sum shown in section 2, above.

**IN WITNESS, the parties below have executed this Agreement, which will become effective on the last date written below.**

<p><b>CONTRACTOR:</b></p> <p>By: _____  <i>(signature)</i></p> <p>Print Name: _____</p> <p>Its _____  <i>(Title)</i></p> <p>DATE: _____</p>	<p><b>CITY OF SUMNER:</b></p> <p>By: _____  <i>(signature)</i></p> <p>Print Name: _____</p> <p>Its _____  <i>(Title)</i></p> <p>DATE: _____</p>
	<p><b>APPROVED AS TO FORM:</b></p> <p>_____</p> <p>Sumner City Attorney</p>

# CHANGE ORDER 02: Additional Driveway, Sidewalk, and Asphalt

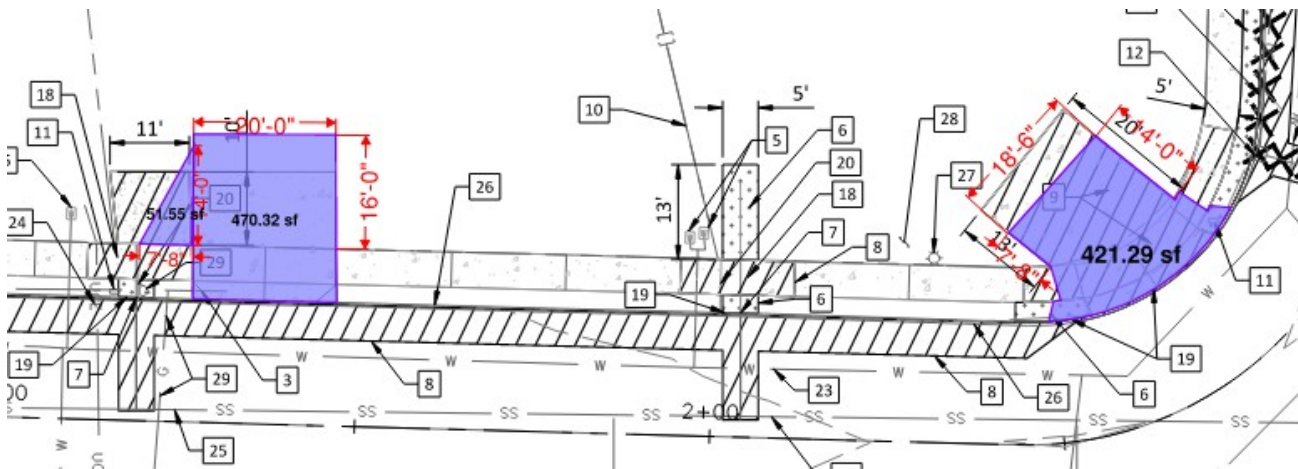
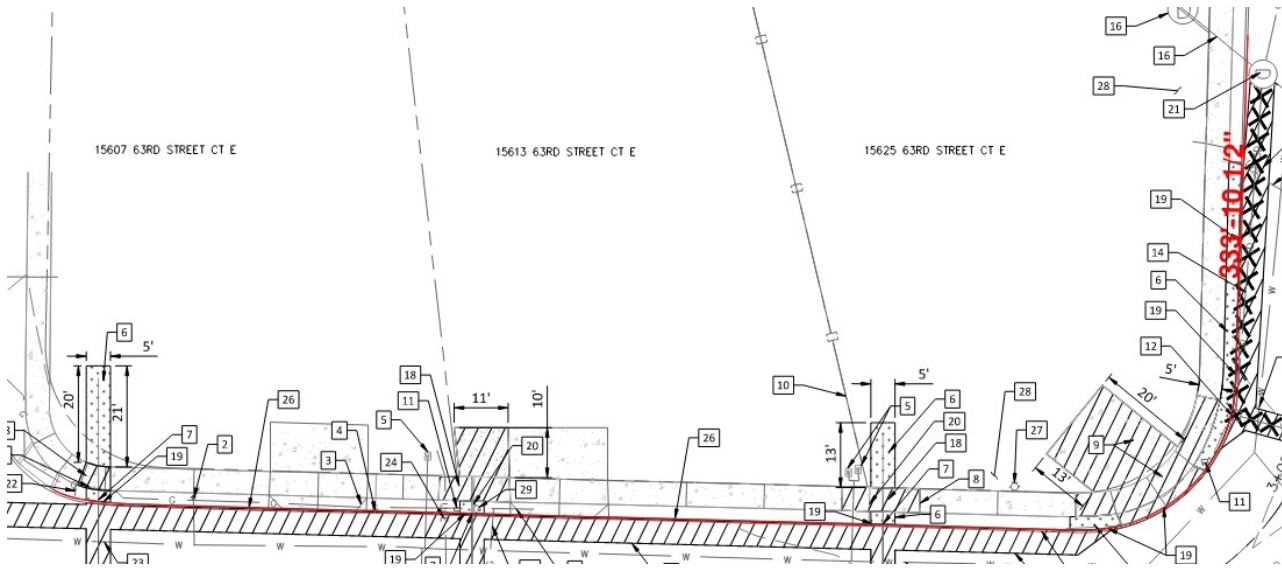
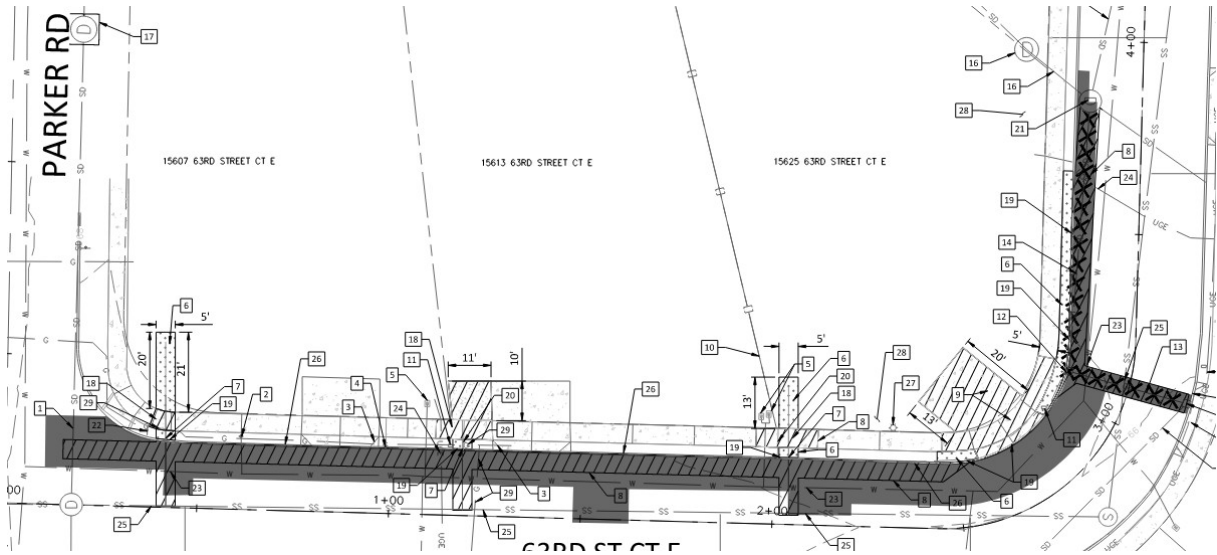

# CHANGE ORDER 02: Additional Driveway, Sidewalk, and Asphalt

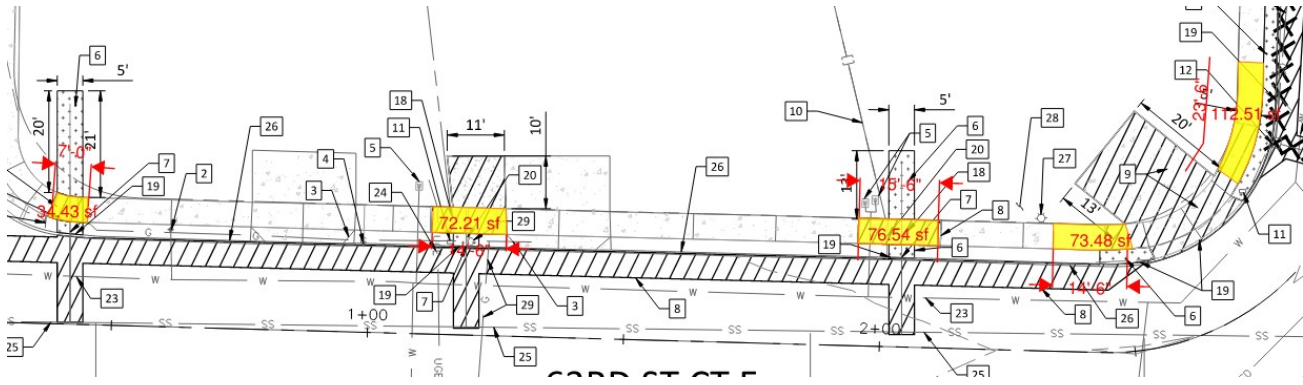

---

**SUBJECT:** Operations Facility - Puget Sound Energy Gas Easement

**CATEGORY:** Consent

---

**BUDGET IMPACT:**

Expenditure Required: None

Within Budget Allocation: N/A

---

**ATTACHMENTS:**

1. Puget Sound Energy Gas Easement Ratification

**STAFF CONTACT:** Drew McCarty, Assistant Engineering Manager

---

**SUMMARY BACKGROUND:**

The Operations Facility project includes the construction of a new public works facility with approximately 102,100 sf of total building space over 6 buildings on a 6.2 Acre site at 14320 29th Street East. The facility will house Public Works, Parks, and Facilities and will include an administration building, vehicle storage, fleet washing, and material storage. The project will also include frontage improvements, landscaping, site lighting and stormwater management.

In order to construct the Operations Facility, Puget Sound Energy (PSE) will need to provide a gas service to the project located at 14320 29th St. E. Per the design, PSE will be installing gas facilities to serve the new project. PSE standards require an easement whenever PSE facilities are installed on private property. PSE has provided an easement that will provide "AN EASEMENT AREA TEN (10) FEET IN WIDTH HAVING FIVE (5) FEET OF SUCH WIDTH ON EACH SIDE OF THE CENTERLINE OF PSE'S FACILITIES AS NOW CONSTRUCTED OR TO BE CONSTRUCTED, EXTENDED OR RELOCATED LYING WITHIN THE EAST TWENTY (20) FEET OF THE WEST ONE-HUNDRED AND SEVENTY (170) FEET OF THE ABOVE DESCRIBED PROPERTY, EXCEPT WHERE BUILDING FOOTINGS, FOUNDATIONS, AND/OR SUBSURFACE STRUCTURES PRECLUDE. IN SUCH CASE, THE FOOTINGS, FOUNDATIONS, AND/OR SUBSURFACE STRUCTURES WILL BECOME THE BOUNDARY OF THIS EASEMENT."

---

**COUNCIL COMMITTEE/STUDY SESSION:** Public Works Committee

**MEETING/STUDY SESSION DATE:** 4/21/2026

**COMMITTEE RECOMMENDATION:** Do Pass

---

**STAFF RECOMMENDATIONS/MOTION:**

A motion authorizing the Mayor to execute any and all necessary easement documents to effectuate the transaction with Puget Sound Energy, as part of the Operations Facility project (CIP 17-13), substantially in a form approved by the City Attorney and ratifying and all prior acts consistent with this authorization.

**RETURN ADDRESS:**

**Puget Sound Energy, Inc.  
Attn: ROW Department / PT  
3130 S 38<sup>th</sup> St  
Tacoma, WA 98409**



**EASEMENT**

**REFERENCE #:**

**GRANTOR (Owner): SUMNER, CITY OF  
GRANTEE (PSE): PUGET SOUND ENERGY, INC.  
SHORT LEGAL: PARCEL A LOT COMB 202207080001 / SW ¼ SE ¼ 12-20N-04E  
ASSESSOR'S PROPERTY TAX PARCEL: 042012-4-068**

For good and valuable consideration, the receipt and sufficiency of which are hereby acknowledged, **CITY OF SUMNER, a Washington municipal corporation** ("Owner"), hereby grants and conveys to **PUGET SOUND ENERGY, INC.**, a Washington corporation ("PSE"), for the purposes hereafter set forth, a nonexclusive perpetual easement over, under, along, across and through the following described real property (the "Property" herein) in Pierce County, State of Washington:

**PARCEL A, CITY OF SUMNER LOT COMBINATION RECORDED JULY 8, 2022 UNDER AUDITOR'S FILE NO. 202207080001, RECORDS OF PIERCE COUNTY, WASHINGTON.**

Except as may be otherwise set forth herein PSE's rights shall be exercised upon that portion of the Property ("Easement Area" herein) described as follows:

**AN EASEMENT AREA TEN (10) FEET IN WIDTH HAVING FIVE (5) FEET OF SUCH WIDTH ON EACH SIDE OF THE CENTERLINE OF PSE'S FACILITIES AS NOW CONSTRUCTED OR TO BE CONSTRUCTED, EXTENDED OR RELOCATED LYING WITHIN THE EAST TWENTY (20) FEET OF THE WEST ONE-HUNDRED AND SEVENTY (170) FEET OF THE ABOVE DESCRIBED PROPERTY, EXCEPT WHERE BUILDING FOOTINGS, FOUNDATIONS, AND/OR SUBSURFACE STRUCTURES PRECLUDE. IN SUCH CASE, THE FOOTINGS, FOUNDATIONS, AND/OR SUBSURFACE STRUCTURES WILL BECOME THE BOUNDARY OF THIS EASEMENT.**

**A DIAGRAM DEPICTING THE APPROXIMATE LOCATION OF THE EASEMENT AREA IS ATTACHED HERETO AS EXHIBIT "A", AS A VISUAL AID ONLY.**

**1. Purpose.** PSE shall have the right to use the Easement Area to construct, operate, maintain, repair, replace, improve, remove, upgrade and extend one or more utility systems for purposes of transmission, distribution and sale of gas. Such systems may include, but are not limited to:

**Underground facilities.** Pipes, pipelines, mains, laterals, conduits, regulators, gauges and rectifiers for gas; fiber optic cable and other lines, cables and facilities for communications; semi-buried or ground-mounted facilities and pads, manholes, meters, fixtures, attachments and any and all other facilities or appurtenances necessary or convenient to any or all of the foregoing.

Following the initial construction of all or a portion of its systems, PSE may, from time to time, construct such additional facilities as it may require for such systems.

**2. Access.** PSE shall have a reasonable right of access to the Easement Area over and across the Property to enable PSE to exercise its rights granted in this easement.

**3. Easement Area Clearing and Maintenance.** PSE shall have the right to cut, remove and dispose of any and all brush, trees or other vegetation in the Easement Area. PSE shall also have the right to control, on a continuing basis and by any prudent and reasonable means, the establishment and growth of brush, trees or other vegetation in the Easement Area.

**4. Trees Outside Easement Area.** PSE shall have the right to cut, trim remove and dispose of any trees located on the Property outside the Easement Area that could, in PSE's reasonable judgment cause damage to PSE's systems and/or present a hazard to the general public health, safety or welfare as defined in RCW 64.12.035. PSE shall, except in the event of an emergency, prior to the exercise of such right, identify such trees and make a reasonable effort to give Owner prior notice that such trees will be cut, trimmed, removed or disposed. Owner shall be entitled to compensation for the actual market value of merchantable timber (if any) cut and removed from the Property by PSE.

**5. Restoration.** Following the initial installation, repair or extension of its facilities, PSE shall, to the extent reasonably practicable, restore landscaping and surfaces and portions of the Property affected by PSE's work to the condition existing immediately prior to such work. PSE shall use good faith efforts to perform its restoration obligations under this paragraph as soon as reasonably possible after the completion of PSE's work.

**6. Owner's Use of Easement Area.** Owner reserves the right to use the Easement Area for any purpose not inconsistent with the rights herein granted, provided, however, Owner shall not perform the following activities without PSE's prior written consent: (1) excavate within or otherwise change the grade of the Easement Area; (2) construct or maintain any buildings, structures or other objects on the Easement Area; and/or (3) conduct any blasting within 300 feet of PSE's facilities.

**7. Indemnity.** PSE agrees to indemnify Owner from and against liability incurred by Owner as a result of PSE's negligence, or the negligence of PSE's employees, agents or contractors in the exercise of the rights herein granted to PSE, but nothing herein shall require PSE to indemnify Owner for that portion of any such liability attributable to the negligence of Owner, its employees, agents or contractors or the negligence of third parties.

**8. Attorneys' Fees.** The prevailing party in any lawsuit brought to enforce or interpret the terms of this Easement shall be entitled to recover its reasonable attorneys' fees and costs incurred in said suit, including on appeal.

**9. Successors and Assigns.** This Easement is binding upon and will inure to the benefit of the successors and permitted assigns. PSE may not assign or otherwise transfer any of its rights, obligations or interest under this Easement without the prior written consent of Owner, which consent may not be unreasonably withheld. Notwithstanding the foregoing, PSE may assign or apportion this Easement or rights hereunder to an affiliate or in connection with a merger, acquisition, corporate reorganization, pledge of assets as collateral, sale of assets or other change in control, joint venture, tenancy-in-common or sale of business lines.

**10. Complete Agreement; Amendment; Counterparts.** This Easement contains the entire agreement of the parties with respect to this subject matter and supersedes all prior writings or discussions relating to the Easement. This Easement may not be amended except by a written document executed by the authorized representatives of Owner and PSE. This Easement may be executed in counterparts, each of which shall be treated as an original for all purposes and all executed counterparts shall constitute one agreement.

**11. Warranty and Representation of Authority.** The parties each represent to the other that the person or persons executing this Easement have authority to do so and to bind the parties hereunder. All consents, permissions and approvals related to this Easement, and the obligations hereunder, have been obtained. Owner further warrants to PSE that it has the necessary right, title and interests in the Property to grant the easement rights set forth herein.

**12. Severability.** Invalidation of any of the provisions contained in this Easement, or of the application thereof to any person, by judgment or court order, shall in no way affect any of the other provisions thereof or the application thereof to any other person and the same shall remain in full force and effect. If a provision is found to be unenforceable or invalid, that provision shall be modified or partially enforced to the maximum extent permitted by law to effectuate the purpose of this agreement.

**13. Non-Waiver.** The failure of any party to insist upon strict performance of any of the terms, covenants or conditions hereof shall not be deemed a waiver of any rights or remedies which that party may have hereunder or at law or equity and shall not be deemed a waiver of any subsequent breach or default in any of such terms, covenants or conditions.

**EXHIBIT "A"  
EASEMENT AREA**

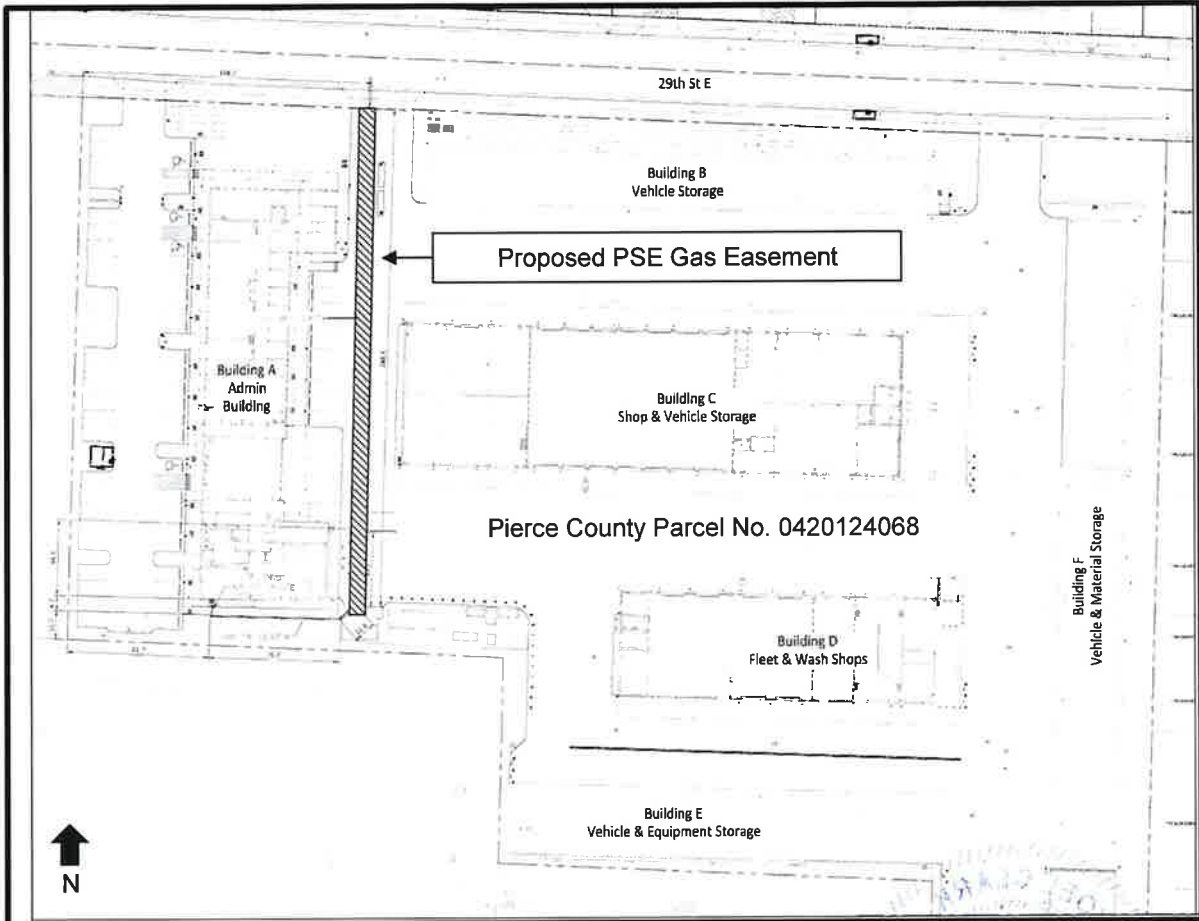

*Graphic meant to serve as visual aid only and does not represent the exact location of PSE's current or future facilities.  
Graphic is not to scale.*

DATED this 9 day of March, 2026

OWNER: CITY OF SUMNER, a Washington municipal corporation

By: Carla S Bowman

Carla S Bowman  
(Print Name)

Its: Mayor  
(Title)

STATE OF WASHINGTON )  
COUNTY OF Pierce ) SS

On this 9th day of March, 2026, before me, the undersigned, a Notary Public in and for the State of Washington, duly commissioned and sworn, personally appeared Carla S. Bowman to me known to be the person(s) who signed as Mayor of **CITY OF SUMNER, a Washington municipal corporation**, the municipal corporation that executed the within and foregoing instrument, and acknowledged said instrument to be his/her free and voluntary act and deed and the free and voluntary act and deed of said municipal corporation for the uses and purposes therein mentioned; and on oath stated that he/she was authorized to execute the said instrument on behalf of said municipal corporation.

IN WITNESS WHEREOF I have hereunto set my hand and official seal the day and year first above written.



Noel Clark  
(Signature of Notary)

Noel Clark  
(Print or stamp name of Notary)

NOTARY PUBLIC in and for the State of Washington, residing at Pierce County, WA

My Appointment Expires: 3/18/2029

Notary seal, text and all notations must be inside 1" margins

---

**SUBJECT:** Heritage Park Remediation - Design Consultant Contract Award

**CATEGORY:** Consent

---

**BUDGET IMPACT:**

Expenditure Required: \$198,038.00

Within Budget Allocation: Yes

---

**ATTACHMENTS:**

1. Consultant Services Contract - Farallon Consulting, LLC

**STAFF CONTACT:** Alisa O'Haver-Ayala , Deputy Public Works Director

---

**SUMMARY BACKGROUND:**

The City of Sumner owns the property at 914 Kincaid Avenue, known as the "Former Sumner Texaco Property". The site is on the Department of Ecology's Confirmed Contaminated Sites List under Site ID 8200. The City desires to undertake a voluntary cleanup of the subject property with the intent to obtain a No Further Action letter from the Washington State Department of Ecology.

Six (6) Statements of Qualifications were received on April 2nd, 2026 for this project. Farallon Consulting, LLC was selected to provide consulting services for this project through a qualification-based selection process. An agreement with a maximum amount payable of \$198,038.00 was negotiated for the design of the project.

---

**COUNCIL COMMITTEE/STUDY SESSION:** Public Works Committee

**MEETING/STUDY SESSION DATE:** 4/21/2026

**COMMITTEE RECOMMENDATION:** Do Pass

**STAFF RECOMMENDATIONS/MOTION:**

A motion authorizing the Mayor and City Administrator to execute all necessary contract documents with Farallon Consulting, LLC, in an amount not-to-exceed \$198,038.00 for the Sumner Texaco Heritage Park Remediation project (CIP 22-04), substantially in a form approved by the City Attorney.

**PROFESSIONAL/CONSULTANT SERVICES CONTRACT**  
**between the CITY OF SUMNER and**  
**Farallon Consulting, L.L.C.**

THIS CONTRACT is made between the CITY OF SUMNER, a Washington municipal corporation (hereinafter the "City"), and Farallon Consulting, L.L.C., organized under the laws of the State of Washington, located and doing business at 13555 SE 36th St Ste 320, Bellevue, WA 98006, (425)295-0803 (hereinafter the "Consultant")(collectively, the "Parties").

**I. DESCRIPTION OF WORK.**

Consultant shall perform the following services for the City in accordance with the attached scope of work/engagement letter:

See Exhibit A. Should any provision of Consultant’s scope of work/engagement letter conflict with any provision of this agreement, this agreement shall govern.

The Consultant further represents that the services furnished under this Contract will be performed in accordance with generally accepted professional practices within the Puget Sound region in effect at the time those services are performed.

**II. TIME OF COMPLETION.** The Parties agree that work will begin on the tasks described in Section I above immediately upon the effective date of this Contract. Upon the effective date of this Contract, Consultant shall complete the work described in Section I by December 31, 2027.

**III. COMPENSATION.**

- A. The City shall pay the Consultant a fee not to exceed \$198,038.00 for the services described in this Contract. This is the maximum amount to be paid under this Contract for the work described in Section I above and shall not be exceeded without the prior written authorization of the City in the form of a negotiated and executed amendment to this Contract.
- B. The Consultant shall submit monthly invoices, unless otherwise agreed in writing by the City. The City shall, upon receipt of Consultant’s monthly invoice, process payment in accordance with the City’s standard payment schedules, but in no event less than forty-five (45) days after receipt of monthly invoice, unless it has provided a written dispute of the invoice (in whole or part) to the Consultant in a timely manner.

**IV. INDEPENDENT CONTRACTOR.** The Parties intend that an Independent Contractor-Employer Relationship will be created by this Contract and that the Consultant has the ability to control and direct the performance and details of its work, the City being interested only in the results obtained under this Contract.

**V. TERMINATION.** Either party may terminate this Contract, with or without cause, upon providing the other party thirty (30) days written notice at its address set forth on the signature block of this Contract. After termination, the City may take possession of all records and data within the Consultant's possession pertaining to this project, which may be used by the City without restriction; provided, however, that the Consultant may retain copies of records and data for business records purposes. If the City's use of the Consultant's records or data is not related to this project, it shall be without liability or legal exposure to the Consultant.

**VI. DISCRIMINATION.** In the hiring of employees for the performance of work under this Contract or any subcontract, the Consultant, its subcontractors, or any person acting on behalf of the Consultant or subcontractor shall not, by reason of race, religion, color, sex, age, sexual orientation, national origin, or the presence of any sensory, mental, or physical disability, discriminate against any person who is qualified and available to perform the work to which the employment relates.

**VII. INDEMNIFICATION.** Consultant shall defend, indemnify and hold the City, its officers, officials, employees, and volunteers harmless from any and all claims, injuries, damages, losses or suits, including attorney fees, arising out of or in connection with the Consultant's intentionally damaging, reckless or negligent performance of this Contract, except for injuries and damages caused by the sole negligence of the City.

Should a court of competent jurisdiction determine that this Contract is subject to RCW 4.24.115, then, in the event of liability for damages arising out of bodily injury to persons or damages to property caused by or resulting from the concurrent negligence of the Consultant and the City, its officers, officials, employees, agents and volunteers, the Consultant's liability hereunder shall be only to the extent of the Consultant's negligence.

IT IS FURTHER SPECIFICALLY AND EXPRESSLY UNDERSTOOD THAT THE INDEMNIFICATION PROVIDED HEREIN CONSTITUTES THE CONSULTANT'S WAIVER OF IMMUNITY UNDER INDUSTRIAL INSURANCE, TITLE 51 RCW, SOLELY FOR THE PURPOSES OF THIS INDEMNIFICATION. THE PARTIES FURTHER ACKNOWLEDGE THAT THEY HAVE MUTUALLY NEGOTIATED THIS WAIVER.

The provisions of this section shall survive the expiration or termination of this Contract.

**VIII. INSURANCE.** The Consultant shall procure and maintain for the duration of this Contract, insurance against claims for injuries to persons or damage to property which may arise from or in connection with the performance of the work hereunder by the Consultant, and/or its agents, representatives, or employees.

**No Limitation.** The Consultant's maintenance of insurance as required by this Contract shall not be construed to limit the liability of the Consultant to the coverage provided by such insurance, or otherwise limit the City's recourse to any remedy available at law or in equity.

**A. Minimum Scope of Insurance.** The Consultant shall obtain insurance of the types described below:

1. Automobile Liability insurance covering all owned, non-owned, hired and leased vehicles. Coverage shall be written on Insurance Services Office (ISO) form CA 00 01 or a substitute form providing equivalent liability coverage. If necessary, the policy shall be endorsed to provide contractual liability coverage.
2. Commercial General Liability insurance shall be written on ISO occurrence form CG 00 01 and shall cover liability arising from premises, operations, independent

contractors and personal injury and advertising injury. The City shall be named as an additional insured under the Consultant's Commercial General Liability insurance policy with respect to the work performed for the City.

3. Workers' Compensation coverage as required by the Industrial Insurance laws of the State of Washington.
4. Professional Liability insurance appropriate to the Consultant's profession in the legal services industry.

**Minimum Amounts of Insurance:** The Consultant shall maintain the following insurance limits during the entire duration of this Contract:

1. Automobile Liability insurance with a minimum combined single limit for bodily injury and property damage of \$1,000,000 per accident.
2. Commercial General Liability insurance shall be written with limits no less than \$2,000,000 each occurrence, \$2,000,000 general aggregate.
3. Professional Liability insurance shall be written with limits no less than \$2,000,000 per claim and \$2,000,000 policy aggregate limit.

**B. Other Insurance Provisions.** The insurance policies are to contain, or be endorsed to contain, the following provisions for Automobile Liability, Professional Liability and Commercial General Liability insurance:

1. The Consultant's insurance coverage shall be primary insurance with respect to the City. Any insurance, self-insurance, or insurance pool coverage maintained by the City shall be excess of the Consultant's insurance and shall not contribute with it.
2. The Consultant's insurance shall be endorsed to state that coverage shall not be cancelled by either party, except after thirty (30) days prior written notice by certified mail, return receipt requested, has been given to the City.

**C. Acceptability of Insurers.** Insurance is to be placed with insurers with a current A.M. Best rating of not less than A:VII.

**D. Verification of Coverage** The Consultant shall furnish the City with original certificates and a copy of the amendatory endorsements, including but not necessarily limited to the additional insured endorsement, evidencing the insurance requirements of the Consultant before commencement of the work hereunder.

**IX. EXCHANGE OF INFORMATION.** The City will provide its best efforts to provide reasonable accuracy of any information supplied by it to the Consultant for the purpose of completion of the work under this Contract.

**X. OWNERSHIP AND USE OF RECORDS AND DOCUMENTS.** Original documents, drawings, designs, reports, or any other records developed or created under this Contract shall belong to and become the property of the City; provided, however, the Consultant has the right, subject to confidentiality, to use the Consultant's work product for internal instructional and other purposes (including as an anonymized template for subsequent work product for the City or other clients). All records submitted by the City to the Consultant will be safeguarded by the Consultant. The Consultant shall make such data, documents, and files available to the City upon the City's request. The City's use or reuse of any of the documents, data and files created by the Consultant for this project by anyone other than the Consultant on any other project shall be without liability or legal exposure to the Consultant.

**XI. CITY'S RIGHT OF INSPECTION.** Even though the Consultant is an independent contractor with the authority to control and direct the performance and details of the work authorized under this Contract, the work must meet the approval of the City and shall be subject to the City's general right of inspection to secure satisfactory completion.

**XII. PUBLIC RECORDS ACT.** The City is required to comply with the Public Records Act, codified in Chapter 42.56 RCW. From time to time, the City will receive requests for public records regarding City business. When a public records request is made regarding work performed or documents created under this Contract, Consultant shall conduct a thorough search of any and all potentially responsive public records created or maintained in the course of completing this Contract, shall provide those documents to the City in a timely manner following the request for search, and shall retain all records in accordance with the retainage schedule as published by the Washington Secretary of State. Following completion of the work pursuant to this contract, Consultant shall provide to the City any and all documents prepared, created or maintained in the course of completing this contract.

**XIII. WORK PERFORMED AT THE CONSULTANT'S RISK.** The Consultant shall take all necessary precautions and shall be responsible for the safety of its employees, agents, and subcontractors in the performance of the contract work and shall utilize all protection necessary for that purpose. All work shall be done at the Consultant's own risk, and the Consultant shall be responsible for any loss of or damage to materials, tools, or other articles used or held for use in connection with the work.

**XIV. MISCELLANEOUS PROVISIONS.**

A. Non-Waiver of Breach. The failure of the City to insist upon strict performance of any of the covenants and agreements contained in this Contract, or to exercise any option conferred by this Contract in one or more instances shall not be construed to be a waiver or relinquishment of those covenants, agreements or options, and the same shall be and remain in full force and effect.

B. Resolution of Disputes and Governing Law.

1. Alternative Dispute Resolution. If a dispute arises from or relates to this Contract or the breach thereof and if the dispute cannot be resolved through direct discussions, the parties agree to endeavor first to settle the dispute in an amicable manner by mediation administered by a mediator under JAMS Alternative Dispute Resolution service rules or policies before resorting to arbitration. The mediator may be selected by agreement of the parties or through JAMS. Following mediation, or upon written agreement of the parties to waive mediation, any unresolved controversy or claim arising from or relating to this Contract or breach thereof shall be settled through arbitration which shall be conducted under JAMS rules or policies. The arbitrator may be selected by agreement of the parties or through JAMS. All fees and expenses for mediation or arbitration shall be borne by the parties equally. However, each party shall bear the expense of its own counsel, experts, witnesses, and preparation and presentation of evidence. Notwithstanding, the foregoing, any claims alleging professional negligence are not subject to arbitration and shall be commenced exclusively in the Pierce County Superior Court or the United States District Court, Western District of Washington as appropriate.

2. Applicable Law and Jurisdiction. This Contract shall be governed by the laws of the State of Washington. Although the agreed to and designated primary dispute resolution method as set forth above, in the event any claim, dispute or action arising from or relating to

this Contract cannot be submitted to arbitration, then it shall be commenced exclusively in the Pierce County Superior Court or the United States District Court, Western District of Washington as appropriate. In any claim or lawsuit for damages arising from the parties' performance of this Agreement, each party shall pay all its legal costs and attorney's fees incurred in defending or bringing such claim or lawsuit, in addition to any other recovery or award provided by law; provided, however, nothing in this paragraph shall be construed to limit the City's right to indemnification under Section VII of this Contract.

C. Written Notice. All communications regarding this Contract shall be sent to the parties at the addresses listed on the signature page of this Contract, unless notified to the contrary. Any written notice hereunder shall become effective three (3) business days after the date of mailing by registered or certified mail, and shall be deemed sufficiently given if sent to the addressee at the address stated in this Contract or such other address as may be hereafter specified in writing.

D. Assignment. Any assignment of this Contract by either party without the written consent of the non-assigning party shall be void. If the non-assigning party gives its consent to any assignment, the terms of this Contract shall continue in full force and effect and no further assignment shall be made without additional written consent.

E. Modification. No waiver, alteration, or modification of any of the provisions of this Contract shall be binding unless in writing and signed by a duly authorized representative of the City and the Consultant.

F. Entire Contract. The written provisions and terms of this Contract, together with any Exhibits attached hereto, shall supersede all prior verbal statements of any officer or other representative of the City, and such statements shall not be effective or be construed as entering into or forming a part of or altering in any manner this Contract. All of the above documents are hereby made a part of this Contract. However, should any language in any of the Exhibits to this Contract conflict with any language contained in this Contract, the terms of this Contract shall prevail.

G. Compliance with Laws. The Consultant agrees to comply with all applicable federal, state, and municipal laws, rules, and regulations that are now effective or in the future become applicable to the Consultant's business, equipment, and personnel engaged in operations covered by this Contract or accruing out of the performance of those operations.

H. Counterparts. This Contract may be executed in any number of counterparts, each of which shall constitute an original, and all of which will together constitute this one Contract.

I. Ratification. The parties agree to ratify and confirm any acts consistent with the authority and prior to the final approval of this contract.

J. Consultant's Employees – Employment Eligibility Requirements (E-Verify). The Consultant and any subcontractors shall comply with E-Verify as set forth in Sumner Municipal Code Chapter 3.30. E-Verify is an Internet-based system operated by United States Citizenship and Immigration Services in partnership with the Social Security Administration. E-Verify is free to employers and is available in all 50 states. E-Verify provides an automated link to federal databases to help employers determine employment eligibility of new hires and the validity of their Social Security numbers. The Consultant shall enroll in, participate in and document use of E-Verify as a condition of the award of this contract. The Consultant shall continue participation in E-Verify throughout the course of the Consultant's contractual relationship with the City. If the Consultant uses or employs any subcontractor in the performance of work under this contract, or

any subsequent renewals, modifications or extension of this contract, the subcontractor shall register in and participate in E-Verify and certify such participation to the Consultant. Upon execution of this Contract, the Consultant shall provide proof of compliance with this section by filling out and signing the attached Certification of Compliance with Sumner’s Municipal Code 3.30 “E-Verify” attached hereto as Exhibit B.

K. Debarment. The Consultant must certify that it, and its subcontractors, have not been and are not currently on the Federal or the Washington State Debarment List and if the Consultant or its subcontractors become listed on the Federal or State Debarment List, the City will be notified immediately.

L. Application of Uniform Guidance. If this contract involves the use, in whole or in part, of federal award(s), 29 CFR 5.5 shall apply. See Exhibit C, attached, and its provisions which are incorporated as if fully set forth herein.

**IN WITNESS, the parties below execute this Contract, which shall become effective on the last date entered below.**

<p><b>CONSULTANT:</b></p> <p>By: _____  <span style="margin-left: 150px;"><i>(signature)</i></span></p> <p>Print Name: _____</p> <p>Title: _____  <span style="margin-left: 150px;"><i>(Title)</i></span></p> <p>DATE: _____</p>	<p><b>CITY OF SUMNER:</b></p> <p>By: _____  <span style="margin-left: 150px;"><i>(signature)</i></span></p> <p>Print Name: <u>Carla S. Bowman</u></p> <p>Its <u>Mayor</u>  <span style="margin-left: 150px;"><i>(Title)</i></span></p> <p>DATE: _____</p> <p>By: _____  <span style="margin-left: 150px;"><i>(signature)</i></span></p> <p>Print Name: <u>Jason Wilson</u></p> <p>Its <u>City Administrator</u>  <span style="margin-left: 150px;"><i>(Title)</i></span></p> <p>DATE: _____</p> <p>Approved as to Form:</p> <p>Attest: _____ Approved as to form: _____</p> <p>_____  City Clerk City Attorney</p> <p>DATE: _____ DATE: _____</p>
<p><b>NOTICES TO BE SENT TO:</b></p> <p><b>CONSULTANT:</b>  James Welles  Farallon Consulting, L.L.C.  13555 SE 36th St Ste 320  Bellevue, WA 98006  425-295-0803 (telephone)  jwelles@farallonconsulting.com (email)</p>	<p><b>NOTICES TO BE SENT TO:</b></p> <p><b>CITY OF SUMNER:</b>  Alisa O’Haver-Ayala  City of Sumner  1104 Maple Street  Sumner, WA 98390  253-299-5703 (telephone)  alisao@sumnerwa.gov (email)</p>



April 15, 2026

Alisa O'Haver-Ayala  
Deputy Public Works Director  
City of Sumner  
1104 Maple Street  
Sumner, Washington 98930

**RE: SCOPE OF WORK AND COST ESTIMATE FOR RI-FS-DCAP  
SUMNER TEXACO  
914 KINCAID AVENUE  
SUMNER, WASHINGTON  
FARALLON PN: 3993-001.001**

Dear Alisa O'Haver-Ayala:

Farallon Consulting, L.L.C. (Farallon) has prepared this letter to present a scope of work and cost estimate to the City of Sumner (City) to complete a Remedial Investigation-Feasibility Study-draft Cleanup Action Plan (RI-FS-dCAP) for the Sumner Texaco cleanup site at 914 Kincaid Avenue in Sumner, Washington (herein referred to as the Site). This letter presents a brief description of Farallon's understanding of the work, a discussion of the scope of work to be completed, and the cost estimate and schedule to conduct the work.

### **BACKGROUND**

The Site was operated as a retail gasoline station from at least 1944 to the early 1990s. The Site is listed on the Washington State Department of Ecology's (Ecology) Confirmed and Suspected Contaminated Sites List (CSCSL) under Facility Site Identification No. 18295642 due to the release of hazardous substances from a former underground storage tank (UST) system associated with the former gas station. The Site is enrolled in Ecology's Voluntary Cleanup Program (VCP) under VCP Project ID SW1841.

A Revised Remedial Investigation report (Revised RI) dated July 22, 2024, prepared for the Site by others, was submitted to Ecology; Ecology responded with an opinion letter dated May 5, 2025 (May 2025 Opinion Letter) stating that Further Action is necessary to characterize and clean up contamination at the Site.

Ecology requested Further Action related to:

- Additional characterization of total petroleum hydrocarbons (TPH) as gasoline-range organics (GRO) and benzene in soil;



- Additional characterization of groundwater impacts in areas located hydraulically cross- and down-gradient of the source area of contamination at the Site;
- Analysis of groundwater samples for TPH as diesel-range organics (DRO) and oil-range organics (ORO) using silica gel cleanup (SGC) in accordance with Ecology's SGC Guidance;
- Additional characterization of the vapor intrusion pathway at the Site, including evaluation of preferential pathways;
- Additional evaluation of the groundwater to surface water pathway from the Site to the nearby Puyallup River; and
- Upload of all Site data collected since August 1, 2005 to Ecology's Environmental Information Management (EIM) database.

Farallon understands that the City's prior consultant installed three additional monitoring wells (MW-7, MW-8, and MW-9) at the Site since issuance of the May 2025 Opinion Letter in locations cross- and down-gradient from the source area at the Site. Two quarterly groundwater monitoring events have been performed at the Site since installation of the new wells.

Based on Farallon's review of the soil and groundwater analytical results from the new monitoring wells, the additional soil characterization requested by Ecology in the May 2025 Opinion Letter has been addressed. Additional groundwater monitoring is recommended at the three new wells to further evaluate groundwater flow and quality, and whether additional delineation of groundwater impacts west of MW-9 is necessary.

Site contamination is comingled with petroleum contamination sourced from the west adjoining Sounder Square cleanup site (Facility Site Identification No. 10188) in the western portion of the Site. Farallon understands that the City intends to delineate the nature and extent of groundwater impacts associated with both releases and work with the owners of the Sounder Square site to develop a final cleanup action for both Sites.



## SCOPE OF WORK

The scope of work for the environmental technical services will be conducted under the following tasks:

- Task 1: Project Management and Communications;
- Task 2: Data Compilation and Management;
- Task 3: Groundwater Monitoring and Reporting
  - Subtask 3A: Quarterly Groundwater Monitoring;
  - Subtask 3B: Groundwater Monitoring Report;
- Task 4: Remedial Investigation Work Plan;
- Task 5: Tier I Vapor Intrusion Evaluation;
- Task 6: Remedial Investigation Addendum;
- Task 7: Feasibility Study;
- Task 8: Draft Cleanup Action Plan; and
- Task 9: Regulatory Correspondence.

A description of work under each task is provided below.

### **TASK 1: PROJECT MANAGEMENT AND COMMUNICATIONS**

Task 1 includes project management duties such as budgeting, scoping, allocating personnel resources, meetings, subcontracting, progress reporting, and communications with the client, representatives of the client, and client contractors as appropriate; and documentation management, including reporting, invoicing, and other administrative duties.

Farallon will prepare a Site-specific Health and Safety Plan for the field work in accordance with the U.S. Occupational Safety and Health Administration guidance, Part 1910.120 of Title 29 of the Code of Federal Regulations, and Washington Administrative Code (WAC) Chapter 296-843.

### **TASK 2: DATA COMPILATION AND MANAGEMENT**

Task 2 includes compilation of existing environmental data for the Site into Farallon's EQulS and GIS databases, and preparation of updated summary figures and analytical results tables for the Site. Compilation of all existing Site data in a unified set of figures and



summary tables will support efficient analysis of environmental conditions, identification of data gaps, and evaluation of cleanup alternatives in the future. Data will be compiled from the following sources:

- Documentation publicly available for the Site on Ecology's CSCSL database;
- The Revised RI Report; and
- Analytical data provided by the City's former consultant collected after completion of the Revised RI.

Data for the Site from other sources will be compiled in Farallon's databases along with the data summarized above as it is made available to Farallon. This task also includes submittal of analytical data from 2005 to present to the EIM database.

Estimated costs presented in this proposal include compilation of the sources listed above and assume that electronic data deliverable (EDD) files for analytical data and AutoCAD/shapefiles for spatial data are available for most (if not all) of the existing data collected by previous consultants. Compilation of data from Excel data tables or PDF reports will result in additional costs beyond those presented herein.

### **TASK 3: GROUNDWATER MONITORING AND REPORTING**

Task 3 comprises quarterly groundwater monitoring for a period of 2 years. Groundwater monitoring and reporting will be addressed under separate subtasks.

#### **SUBTASK 3A: QUARTERLY GROUNDWATER MONITORING**

Subtask 3A includes completion of seven quarterly groundwater monitoring events at nine existing monitoring wells at the Site.

#### **Groundwater Monitoring**

To perform the groundwater monitoring and sampling, Farallon field personnel will remove the locking well cap from each monitoring well, and groundwater levels will be allowed to equilibrate to atmospheric pressure for at least 15 minutes. The depth to groundwater will be measured in each monitoring well to the nearest 0.01 foot using an electronic water-level measuring device to the top of the well casing. The total depth of each monitoring well will be measured to evaluate siltation of the well-screen interval and to calculate the submerged well-casing volume. Reusable equipment will be decontaminated between use at each location.



Each monitoring well will be purged at a low-flow rate ranging from 100 to 300 milliliters per minute using a peristaltic or bladder pump and dedicated tubing. Temperature, pH, specific conductance, dissolved oxygen, and oxidation-reduction potential will be monitored during purging to determine when stabilization of these parameters occurs. Following stabilization of the parameters, groundwater samples will be collected directly from the low-flow pump outlet. If low-flow sampling methods are not practicable due to low yield and dewatering of the monitoring well, the monitoring well will be allowed to recharge for no more than 2 hours from cessation of purging, after which groundwater will be sampled.

### **Laboratory Analysis**

Laboratory-prepared sample containers will be filled directly from the pump outlet, with care taken to minimize turbulence and not handle the seal or lid of the container when the samples are placed into the containers. The samples will be placed on ice in a cooler under standard chain-of-custody protocols.

Groundwater samples will be submitted on a standard 1-week laboratory turnaround time to an Ecology-accredited analytical laboratory for the following analyses:

- GRO by Method NWTPH-Gx;
- DRO and ORO by Method NWTPH-Dx. Samples from monitoring well MW-2 will be analyzed by Method NWTPH-Dx with and without SGC;
- Benzene, toluene, ethylbenzene, and xylenes (BTEX) by U.S. Environmental Protection Agency (EPA) Method 8021;
- 1,2-Dibromoethane (EDB), 1,2-dichloroethane (EDC), and methyl-tertiary butyl ether (MTBE) by EPA Method 8260; and
- Dissolved lead by EPA Method 6010/6020.

Costs presented in this proposal include performance of seven quarterly groundwater monitoring events, which includes the three remaining quarterly monitoring events for completion in 2026 and four quarterly monitoring events in 2027.

Should analytical results and correspondence with Ecology indicate that groundwater monitoring is not required through the end of 2027, groundwater monitoring may be discontinued before all seven events have been performed.



Investigation-derived waste in the form of purge water generated during groundwater sampling will be temporarily stored on-site in 55-gallon Department of Transportation-approved steel drums pending profiling and disposal. Drums will be removed from the Site following each groundwater monitoring event within 3 weeks of receipt of analytical data. Costs assume drums are removed from the Site quarterly.

Groundwater analytical data will be summarized in analytical data tables and provided to the City within 2 weeks of receipt of analytical data from each monitoring event. Groundwater analytical data will be formally presented in the Groundwater Monitoring Report under Subtask 3B and the RI Addendum under Task 6.

### **SUBTASK 3B: GROUNDWATER MONITORING REPORT**

This subtask includes preparation of a groundwater monitoring summary report for data collected after completion of the RI Addendum (Task 6). Data collected prior to finalizing the RI Addendum will be incorporated therein.

### **TASK 4: REMEDIAL INVESTIGATION WORK PLAN**

Task 4 includes preparation of a Remedial Investigation Work Plan (Work Plan) to address the actions requested by Ecology in the May 2025 Opinion Letter. The Work Plan will include an evaluation of the soil vapor to indoor air and groundwater to surface water pathways, including assessment of preferential pathways.

Evaluation of preferential pathways will include preparation of updated maps and geologic cross sections illustrating the location and elevations of identified releases, subsurface utilities, and other relevant features at the Site. The preferential pathways evaluation will provide specific recommendations for further evaluation of the soil vapor to indoor air and groundwater to surface water pathways.

### **TASK 5: TIER I VAPOR INTRUSION EVALUATION**

Farallon will perform a Tier I vapor intrusion evaluation of properties located down-gradient from the Site west of Cherry Avenue and north of Maple Street in accordance with Ecology's *Guidance for Evaluating Vapor Intrusion in Washington State* dated March 2022. Farallon anticipates requests for access to perform soil vapor or indoor air sampling within the interior spaces of 908 and 918 Cherry Avenue will likely be denied by the building owner. As such, vapor intrusion evaluation of these spaces is anticipated to be performed in the hydraulically up-gradient right-of-way.



The vapor intrusion evaluation will include installation of up to six subslab soil gas monitoring points within the sidewalk on the west side of Cherry Avenue. The soil gas monitoring points will be collocated within suspected preferential pathways identified in the Work Plan. The subslab soil gas monitoring points will be installed by coring through the concrete slab foundation using a hand-held Roto Hammer drill to install a 5/8-inch-diameter core through the slab. A Vapor Pin and associated cover will then be installed and sealed at the borehole interface via a silicone sleeve.

Two soil gas monitoring events will be performed at the soil gas monitoring points. The events will be performed on a falling barometer in the summer and winter seasons to evaluate seasonal variability of vapor intrusion conditions at the Site.

### **Soil Gas Sampling**

Soil gas monitoring events will consist of collection of one subslab soil gas sample from each monitoring point following Farallon's standard soil gas sampling procedures. The sampling procedure will use real-time leak detection methods to assess for possible leaks in the monitoring probe seal or sampling train.

If no evidence of leaks in the monitoring probe seal or sampling train is detected, the soil gas samples will be collected in a 1-liter Summa canister using laboratory-provided flow controllers to allow a maximum flow rate of 200 milliliters per minute, a rate typically recommended for collection of representative soil gas samples. After completion of the sampling, the permanent subslab soil gas monitoring points will be covered with a flush-mounted cap for future accessibility, if necessary. Costs for removal of the subslab soil gas monitoring points or repair of flooring materials are not included herein and can be estimated upon request.

The subslab soil gas samples will be submitted to a laboratory accredited by the Ecology for analysis of air phase hydrocarbons, BTEX, and naphthalene by EPA Method TO-15.

### **TASK 6: REMEDIAL INVESTIGATION ADDENDUM**

Task 6 includes preparation of a Remedial Investigation Report Addendum (RI Addendum), which will amend the Revised RI to include the results from the additional remedial



investigation activities presented in the Work Plan and recently completed by others, including:

- Installation of monitoring wells MW-7, MW-8, and MW-9 by the City's former consultant;
- Quarterly groundwater monitoring described under Task 3; and
- Completion of the Tier I Vapor Intrusion Evaluation under Task 5.

The RI Addendum will include a revised conceptual site model and amend other aspects of the Revised RI as necessary to establish cleanup standards and support development and evaluation of technically feasible cleanup action alternatives in accordance with Washington Administrative Code (WAC) 173-340-350.

A draft of the RI Addendum will be provided to the City for its review and comment. Upon receipt of comments from the City, Farallon will finalize the RI Addendum and provide a final version to Ecology with a request for a Partial Sufficiency opinion to confirm the RI is complete.

#### **TASK 7: FEASIBILITY STUDY**

Task 7 includes completion of a Feasibility Study (FS) in accordance with WAC 173-340-351. The purpose of the FS is to use the data presented in the Revised RI and RI Addendum to develop and evaluate potential cleanup actions that meet the requirements in WAC 173-340-360 and expectations in WAC 173-340-370, and to facilitate selection of a cleanup action for the Site.

A draft of the FS will be provided to the City for its review and comment. Upon receipt of comments from the City, Farallon will finalize the FS and provide a final version to Ecology for review with a request for a Partial Sufficiency opinion confirming the preferred cleanup action be adopted as final.

#### **TASK 8: DRAFT CLEANUP ACTION PLAN**

Task 8 includes completion of a draft Cleanup Action Plan (dCAP) in accordance with WAC 173-340-380. The purpose of the dCAP is to describe the final cleanup action selected in the FS and to specify the cleanup standards and other requirements the cleanup action must meet. The dCAP will be developed in coordination with the City to identify and minimize potential impacts to public facilities and public uses.



The dCAP will be provided to the City for its review and comment. Upon receipt of comments from the City, Farallon will finalize the CAP and provide a final version to Ecology with a request for a No Further Action Likely opinion pending completion of the cleanup action and attaining cleanup standards for media of concern.

#### **TASK 9: REGULATORY CORRESPONDENCE**

Task 9 addresses Farallon's labor related to communications, coordination, and meetings with the City and Ecology, as appropriate. This scope of work includes assistance with ongoing enrollment in VCP and associated engagements between Farallon, the City, and Ecology.

This task does not include Ecology's fees for participation in the VCP, which are payable directly to Ecology.

#### **COST ESTIMATE**

The estimated time and material cost to conduct the scope of work is \$198,038. Estimated costs are detailed in Table 1 in accordance with Farallon's *2026 Schedule of Charges I*, subject to periodic adjustment. The laboratory analytical fees included in Table 1 are based on a standard laboratory turnaround time of 1 week. The cost estimate is valid for 90 days from the date of this letter.

The estimated cost is based on project conditions and the scope of work described herein. Variations in the scope of work and/or project schedule may require modification of the fee, project schedule, and/or respective report contents. No change in the scope of work defined herein will be initiated without authorization from the City.

Attached are Farallon's *Consulting Services Agreement 3993* and *Work Order 3993-001.001-WO 001* for performing the scope of work presented in this letter. To authorize the above scope of work and cost estimate, please sign and return both documents, and fully executed copies will be returned to you for your records. Additional work conducted at the Site will be authorized by preparation of specific work orders.

#### **SCHEDULE**

Farallon will initiate the proposed scope of work immediately upon receiving written authorization to proceed. Farallon will deliver a draft of the Work Plan within 4 weeks of authorization to proceed with the scope of work presented herein.



## CLOSING

Farallon appreciates the opportunity to provide environmental consulting services to the City. Please contact either of the undersigned at (425) 295-0800 if you have questions or comments regarding this scope of work and cost estimate.

Sincerely,

**Farallon Consulting, L.L.C.**

Nathan Dickey, L.G.  
Associate Geologist

James Welles, L.H.G.  
Principal Hydrogeologist

Attachments: *Table 1, Cost Estimate for Work Order 3993-001.001-WO 001*  
*Consulting Services Agreement 3993*  
*Work Order 3993-001.001-WO 001*  
*2026 Schedule of Charges I*

ND/JW:mbg

**Table 1**  
**Cost Estimate for Work Order 3993-001.001-WO 001**  
**Sumner Texaco**  
**Sumner, Washington**  
**Farallon PN: 3993-001.001**

**Task 1: Project Management and Communications**

<u>Labor</u>	<u>Unit</u>	<u>Rate</u>	<u>Cost</u>
Principal II	12 hour(s) @	\$278 per hour =	\$3,336
Associate II	18 hour(s) @	\$218 per hour =	\$3,924
Technical Editor	4 hour(s) @	\$140 per hour =	\$560
Project Assistant	6 hour(s) @	\$125 per hour =	\$750
<b>Task 1 Estimated Total</b>			<b>\$8,570</b>

**Task 2: Data Compilation and Management**

<u>Labor</u>	<u>Unit</u>	<u>Rate</u>	<u>Cost</u>
Principal II	2 hour(s) @	\$278 per hour =	\$556
Associate II	4 hour(s) @	\$218 per hour =	\$872
Associate Analyst	54 hour(s) @	\$195 per hour =	\$10,530
GIS Analyst	24 hour(s) @	\$196 per hour =	\$4,704
<b>Task 2 Estimated Total</b>			<b>\$16,662</b>

**Task 3: Groundwater Monitoring and Reporting**

**Subtask 3A: Quarterly Groundwater Monitoring**

<u>Labor</u>	<u>Unit</u>	<u>Rate</u>	<u>Cost</u>
Principal II	8 hour(s) @	\$278 per hour =	\$2,224
Associate II	28 hour(s) @	\$218 per hour =	\$6,104
Staff I	154 hour(s) @	\$172 per hour =	\$26,488
Associate Analyst	14 hour(s) @	\$195 per hour =	\$2,730
<b>Subtask 3A Estimated Labor Subtotal</b>			<b>\$37,546</b>

**Other Direct Costs (ODCs)**

**Field Instruments and Equipment:**

<u>Unit</u>	<u>Rate</u>	<u>Cost</u>
Field Truck	14 day(s) @ \$90 per day =	\$1,260
Field Truck Mileage	980 mile(s) @ \$0.75 per mile =	\$735
Level D PPE	14 day(s) @ \$25 per day =	\$350
Peristaltic Pump	14 day(s) @ \$75 per day =	\$1,050
Sampling/Decon Kit	14 day(s) @ \$60 per day =	\$840
Water Level Meter	14 day(s) @ \$30 per day =	\$420
YSI/Horiba Multiparameter Meter	14 day(s) @ \$150 per day =	\$2,100

**Field Supplies:**

Waste Disposal Drum	2 @ \$105 each =	\$210
Water Sample Field Filter	63 @ \$25 each =	\$1,575

**Subcontractors:**

Waste Disposal Vendor	1 estimate @ \$4,900 =	\$4,900
-----------------------	------------------------	---------

**Laboratory Costs**

**Groundwater Analysis:**

GRO (NWTPH-Gx)	70 sample(s) @ \$75 per sample =	\$5,250
DRO and ORO (NWTPH-Dx)	70 sample(s) @ \$87 per sample =	\$6,090
DRO and ORO w/SGC (NWTPH-Dx)	7 sample(s) @ \$121 per sample =	\$847
Petroleum VOCs (EPA 8260)	70 sample(s) @ \$144 per sample =	\$10,080
Dissolved Lead (EPA 6020)	70 sample(s) @ \$41 per sample =	\$2,870
RCRA 8 Metals	2 sample(s) @ \$69 per sample =	\$138

**Subtask 3A Estimated ODCs and Laboratory Costs Subtotal** **\$38,715**

**Subtask 3A Estimated Total** **\$76,261**

**Table 1**  
**Cost Estimate for Work Order 3993-001.001-WO 001**  
**Sumner Texaco**  
**Sumner, Washington**  
**Farallon PN: 3993-001.001**

**Subtask 3B: Groundwater Monitoring Report**

<u>Labor</u>	<u>Unit</u>	<u>Rate</u>	<u>Cost</u>
Principal II	4 hour(s) @	\$278 per hour =	\$1,112
Associate II	12 hour(s) @	\$218 per hour =	\$2,616
Project II	8 hour(s) @	\$189 per hour =	\$1,512
Associate Analyst	4 hour(s) @	\$195 per hour =	\$780
GIS Analyst	8 hour(s) @	\$196 per hour =	\$1,568
Senior CAD Technician	4 hour(s) @	\$159 per hour =	\$636
Technical Editor	4 hour(s) @	\$140 per hour =	\$560
<b>Subtask 3B Estimated Total</b>			<b>\$8,784</b>

**Task 3 Total** **\$85,045**

**Task 4: Remedial Investigation Work Plan**

<u>Labor</u>	<u>Unit</u>	<u>Rate</u>	<u>Cost</u>
Principal II	12 hour(s) @	\$278 per hour =	\$3,336
Associate II	32 hour(s) @	\$218 per hour =	\$6,976
Project I	8 hour(s) @	\$201 per hour =	\$1,608
Associate Analyst	8 hour(s) @	\$195 per hour =	\$1,560
GIS Analyst	8 hour(s) @	\$196 per hour =	\$1,568
CAD/Graphics Technician	8 hour(s) @	\$135	\$1,080
Technical Editor	4 hour(s) @	\$140 per hour =	\$560
<b>Task 4 Estimated Total</b>			<b>\$16,688</b>

**Task 5: Tier I Vapor Intrusion Evaluation**

<u>Labor</u>	<u>Unit</u>	<u>Rate</u>	<u>Cost</u>
Principal II	4 hour(s) @	\$278 per hour =	\$1,112
Associate II	8 hour(s) @	\$218 per hour =	\$1,744
Staff I	36 hour(s) @	\$172 per hour =	\$6,192
<b>Task 5 Estimated Labor Subtotal</b>			<b>\$9,048</b>

**Other Direct Costs (ODCs)**

**Field Instruments and Equipment:**

<u>Unit</u>	<u>Rate</u>	<u>Cost</u>
Field Tool Kit, H.D.	1 day(s) @	\$30 per day = \$30
Field Truck	2 day(s) @	\$90 per day = \$180
Field Truck Mileage	80 mile(s) @	\$0.75 per mile = \$60
Helium Detector	2 day(s) @	\$130 per day = \$260
Level D PPE	2 day(s) @	\$25 per day = \$50
Mini Air Pump	2 day(s) @	\$45 per day = \$90
Photoionization Detector	2 day(s) @	\$105 per day = \$210
Rotary Hammer	1 day(s) @	\$65 per day = \$65
Vapor Intrusion Sampling Kit	2 day(s) @	\$60 per day = \$120

**Field Supplies:**

Vapor Pin	5 @	\$140 each = \$700
-----------	-----	--------------------

**Air/Vapor Analysis:**

APH + BTEX and naphthalene	12 sample(s) @	\$374 per sample = \$4,488
Sampling Manifolds	12 sample(s) @	\$58 per sample = \$696

**Task 5 Estimated ODCs and Laboratory Costs Subtotal** **\$6,949**

**Task 5 Estimated Total** **\$15,997**

**Table 1**  
**Cost Estimate for Work Order 3993-001.001-WO 001**  
**Sumner Texaco**  
**Sumner, Washington**  
**Farallon PN: 3993-001.001**

**Task 6: Remedial Investigation Addendum**

<u>Labor</u>	<u>Unit</u>	<u>Rate</u>	<u>Cost</u>
Principal II	12 hour(s) @	\$278 per hour =	\$3,336
Associate II	32 hour(s) @	\$218 per hour =	\$6,976
Project I	8 hour(s) @	\$201 per hour =	\$1,608
Associate Analyst	8 hour(s) @	\$195 per hour =	\$1,560
GIS Analyst	8 hour(s) @	\$196 per hour =	\$1,568
Technical Editor	4 hour(s) @	\$140 per hour =	\$560
<b>Task 6 Estimated Total</b>			<b>\$15,608</b>

**Task 7: Feasibility Study**

<u>Labor</u>	<u>Unit</u>	<u>Rate</u>	<u>Cost</u>
Principal I	8 hour(s) @	\$307 per hour =	\$2,456
Principal II	8 hour(s) @	\$278 per hour =	\$2,224
Senior I	16 hour(s) @	\$254 per hour =	\$4,064
Associate II	24 hour(s) @	\$218 per hour =	\$5,232
Associate Analyst	8 hour(s) @	\$195 per hour =	\$1,560
GIS Analyst	8 hour(s) @	\$196 per hour =	\$1,568
Technical Editor	4 hour(s) @	\$140 per hour =	\$560
Project Assistant	4 hour(s) @	\$125 per hour =	\$500
<b>Task 7 Estimated Total</b>			<b>\$18,164</b>

**Task 8: Draft Cleanup Action Plan**

<u>Labor</u>	<u>Unit</u>	<u>Rate</u>	<u>Cost</u>
Principal II	8 hour(s) @	\$278 per hour =	\$2,224
Associate II	24 hour(s) @	\$218 per hour =	\$5,232
Associate Analyst	8 hour(s) @	\$195 per hour =	\$1,560
GIS Analyst	8 hour(s) @	\$196 per hour =	\$1,568
Technical Editor	4 hour(s) @	\$140 per hour =	\$560
<b>Task 8 Estimated Total</b>			<b>\$11,144</b>

**Task 9: Regulatory Correspondence**

<u>Labor</u>	<u>Unit</u>	<u>Rate</u>	<u>Cost</u>
Principal II	24 hour(s) @	\$278 per hour =	\$6,672
Associate II	16 hour(s) @	\$218 per hour =	\$3,488
<b>Task 9 Estimated Total</b>			<b>\$10,160</b>

**ESTIMATED PROJECT TOTAL** \$198,038



**CONSULTING SERVICES AGREEMENT 3993  
FARALLON CONSULTING, L.L.C.  
AND  
CITY OF SUMNER**

**THIS CONSULTING SERVICES AGREEMENT, CSA 3993 (Agreement)**, is made effective as of **April 15, 2026** (CSA EFFECTIVE DATE) by and between CITY OF SUMNER, a Washington municipal government organization (CLIENT), and FARALLON CONSULTING, L.L.C. (FARALLON), a Washington limited liability company.

WHEREAS, FARALLON is engaged in the business of providing consulting services and CLIENT may require such services from time to time, and CLIENT (but not FARALLON) will retain control over the subject of the work;

NOW, THEREFORE, in consideration of the terms, provisions, and agreements set forth herein, the parties agree as follows:

**ARTICLE 1.0           SCOPE OF SERVICES**

**1.1    Work Orders.** FARALLON shall provide the scope of work services to be performed (Work) as set forth in a Work Order authorized by CLIENT and accepted by FARALLON. Approval of the Work via email authorization from CLIENT is acceptable under this Agreement.

**1.2    Work Change Orders.** All changes to the Work, as specifically set forth in the Work Order, shall be mutually agreed upon and shall be set forth in a Work Change Order authorized by CLIENT and accepted by FARALLON. Alternatively, email correspondence between the CLIENT and FARALLON describing mutually agreed upon changes to the Work or additional services and costs are deemed an acceptable means of authorization under this Agreement.

Each Work Order and Work Change Order shall include the following:

- (a) Location at which the Work is to be performed;
- (b) Specific scope and description of the Work to be performed, including plans and specifications where appropriate;
- (c) Schedule for commencement of the Work Order or Work Change Order;
- (d) Estimated cost; and
- (e) Indication that Health and Safety Plan is required.

**ARTICLE 2.0           CHARGES AND BILLING**

**2.1    Schedule of Charges.** CLIENT shall pay FARALLON in accordance with the Schedule of Charges referenced in the Work Order or Work Change Order. The FARALLON Schedule of Charges is updated periodically.

**2.2    Invoices.** FARALLON shall invoice the CLIENT monthly for work performed in accordance with the agreed Work Order or Work Change Order. Transmittal of the invoice may be via email, via U.S. mail, or via submission through accounting portal. CLIENT shall timely review such invoices and shall notify FARALLON within ten (10) days of receipt of invoice of any disputed amounts. All undisputed amounts shall be paid no later than thirty (30) days after receipt of the invoice; undisputed amounts remaining unpaid for more than thirty (30) days after the



date of the invoice shall be subject to a finance charge of one percent (1%) per month and legal or other fees if collection action is required to be taken by FARALLON against CLIENT. Delinquencies beyond ninety (90) days may result in a work stoppage until the account is brought current. Additionally, FARALLON may require a retainer to recommence services after such delinquencies.

### ARTICLE 3.0 TERMS AND CONDITIONS OF AGREEMENT AND TERMINATION

- 3.1 Term and termination.** The agreement shall become effective on the CSA EFFECTIVE DATE and continue for a term of three (3) years. Thereafter, this Agreement will automatically renew on an annual basis unless terminated by either party, with or without cause.
- 3.2 Severability of Terms.** Every part, provision, or term of the Agreement is severable from every other part, provision, or term. A finding that any part or provision is invalid, void, or unenforceable shall not affect the remaining parts and provisions.
- 3.3 Agreement Between Parties.** The terms and conditions set forth in the Agreement, together with any Work Order, Work Change Order, or email authorization, constitute the entire understanding of the parties relative to services provided by FARALLON to CLIENT, and supersede and completely integrate any and all prior agreements between the parties, whether oral or in writing.
- 3.4 Incorporated in Work Orders.** The Agreement shall be incorporated in the Work Order and all Work Change Orders and authorizations, and shall govern each such order unless expressly excluded in writing therefrom.
- 3.5 Termination or Suspension.** Either party, may, at any time and with or without cause, terminate or suspend all or a portion of the services remaining to be performed under the scope of work by notifying the other party in writing of any termination or suspension of all or any portion of the services remaining to be performed under the scope of work. Such written notice must be provided to the other party ten (10) business days in advance of termination date. In the event of such termination or suspension by CLIENT, CLIENT will pay FARALLON for all services performed prior to FARALLON's receipt of written notice, and CLIENT will pay FARALLON for any services performed in accordance with CLIENT's instructions after receipt of written notice, and for such Work as may be necessary to effect an orderly termination or suspension.

### ARTICLE 4.0 RECORDS

- 4.1 Retention.** FARALLON shall maintain adequate books, records, and documentation to justify all charges, expenses, and costs incurred in performing services to CLIENT. Upon reasonable notice, and for a period not to exceed three (3) years after the date the services are completed pursuant hereto, CLIENT, at its expense and during business hours, may inspect and audit all records of FARALLON in connection with all costs and expenses invoiced for material cost and costs for reimbursable services. No inspection or audit shall delay or defer the obligation of CLIENT to make payment on undisputed invoices. Upon request and at CLIENT's expense, CLIENT and FARALLON shall make arrangements for the transfer of said records to CLIENT to the extent requested by CLIENT. FARALLON shall have the right to copy



such portions of said records as it shall deem necessary to retain and shall have the right thereafter to request copies of such transferred records.

## ARTICLE 5.0 TIME FOR PERFORMANCE, EXTENSIONS, AND DELAYS

- 5.1 Timely Performance.** FARALLON shall commence and complete the Work in accordance with the schedule set forth in the Work Order or Work Change Order or as otherwise agreed upon by FARALLON and CLIENT, and shall, at all times, proceed diligently with the Work to completion.
- 5.2 Suspension of Work.** CLIENT reserves the right to suspend the whole or any part of the Work under any Work Order or Work Change Order at any time. If all projected work contemplated in a Work Order or Work Change Order is terminated or abandoned by CLIENT, CLIENT shall pay FARALLON for the Work performed in conformity with the authorized scope of work, plans, or specifications, and in accordance with the Schedule of Charges. Suspensions exceeding sixty (60) days may result in changes in project costs to conduct the projected work and in the event of such suspension exceeding sixty (60) days, CLIENT and FARALLON agree to negotiate in good faith to resolve any changes in project costs with a new Work Order, Work Change Order, or email authorization.
- 5.3 Delays.** If FARALLON is obstructed or delayed in the prosecution or completion of the Work by reason of unusual action of the elements, or by reason of abandonment of the Work by the employees in a general strike, or by reason of war, pandemic or epidemic or other public health emergency, civil disorder, fire or other casualty, strikes or embargoes, or shortage of transportation facilities, or by reason of any cause beyond the reasonable control of FARALLON or CLIENT, CLIENT shall have no claim for damages. In any such event, FARALLON shall be entitled to such extension of time for the completion of the Work as CLIENT may approve as being just and proper; provided, however, that such claim for extension of time shall be made by FARALLON, by Work Change Order, to CLIENT, within one (1) week from the time when cause for delay occurs.

## ARTICLE 6.0 PERFORMANCE OF SERVICES AND COMMUNICATION RESULTS

- 6.1 Standard.** FARALLON shall perform the Work in a professional manner consistent with that level of care and skill ordinarily exercised by members of the profession currently practicing in the same locality under similar conditions. No other representation, expressed or implied, and no warranty or guarantee is included or intended herein, or in any report, document or otherwise.
- 6.2 Results.** Results of FARALLON's Work and analyses shall be communicated to CLIENT as required in the Work.

## ARTICLE 7.0 EMPLOYEES

- 7.1 Labor.** FARALLON shall promptly pay all labor used by it in performing the Work and shall, if required, furnish CLIENT with the names of any and all persons, including lien waivers for all labor so used.



**7.2 Compliance with Laws and Regulations.** FARALLON shall conform to applicable federal and state enactments with reference to employer's liability, unemployment security, worker's compensation, worker's insurance, environmental laws and regulations, and occupational safety and health laws in effect in the jurisdiction in which the Work is performed. FARALLON shall maintain such liability and compensation insurance at all times during the term of this Agreement as will protect FARALLON from claims by any FARALLON employee for worker's compensation. FARALLON shall comply with all applicable laws regarding nondiscrimination, age, citizenship, hours, wages, and conditions of employment that may be in effect in the jurisdiction in which the Work is performed.

**7.3 Employee Safety.**

- (a) FARALLON shall be responsible for the health and safety of its employees.
- (b) FARALLON shall comply with applicable U.S. Occupational Safety and Health Administration regulations and rules pertaining to its employees and shall, at its expense, obtain all required occupational Safety and Health Administration certificates, permits, and/or licenses.
- (c) FARALLON shall comply with applicable CLIENT project- and facility-specific health and safety requirements. CLIENT shall notify FARALLON of any such requirements or specific safety hazards and provide FARALLON with a written copy of any such requirements prior to commencement of Work.
- (d) CLIENT, if the owner and/or operator of the jobsite, shall maintain the jobsite free of unlawful discrimination and harassment, including sexual harassment. CLIENT is liable for any discrimination and harassment directed at FARALLON employees by CLIENT agents and subcontractors

**ARTICLE 8.0 INSURANCE AND INDEMNIFICATION**

**8.1 Insurance.** FARALLON shall carry adequate insurance protection against loss, damage, injury, and liability, including claims for personal injury or death, property damage, and damage to the Work resulting from operations under this Agreement, Work Order, and Work Change Order; coverage shall be not less than one million dollars (\$1,000,000) per occurrence and two million dollars (\$2,000,000) in the aggregate. In addition, FARALLON shall carry professional liability (errors and omissions) insurance coverage with minimum limits of one million dollars (\$1,000,000) per claim and aggregate. With the exception of professional liability and worker's compensation, if requested by CLIENT, CLIENT shall be named as an Additional Insured under the insurance policies carried by FARALLON hereunder. CLIENT shall carry adequate insurance protection against loss, damage, injury, and liability, including claims for personal injury, death, or property damage, in commercially reasonable amounts.

**8.2 Certificates.** If requested by CLIENT, Documentary evidence of insurance required of FARALLON by this Agreement shall be furnished to CLIENT by FARALLON before commencing work hereunder, and such certificates will renew annually for a period of three (3) years after the conclusion of work on a per-project basis. The insurance policies hereunder shall provide that notices by the insurer to the insured be given simultaneously to CLIENT, and that at least ten (10) days prior to cancellation of such policies, notice shall be given to CLIENT.



### 8.3 Indemnification.

- (a) FARALLON covenants and agrees to fully defend, protect, indemnify, and hold harmless CLIENT and its employees and agents from and against each and every claim, demand, or cause of action, and any liability, cost, expense, damage or loss in connection therewith which may be made or asserted by FARALLON, FARALLON's employees, agents, or third parties on account of personal injury, death, or property damage, to the extent caused by or arising out of the negligent or intentional actions of FARALLON in the performance of the Work hereunder, but not to the extent caused by the negligent or intentional acts of CLIENT or its employees or any third parties. It is specifically and expressly understood that the indemnification provided in this paragraph constitutes a waiver by FARALLON of immunity under the Industrial Insurance Act (Title 51 RCW) to the extent that such waiver is expressly required by the laws of the state of Washington.
- (i) Notwithstanding any other provision of this Agreement, FARALLON's liability arising from or related to the Work arising from any Work Order or Work Change Order shall be limited to the extent of any insurance policy obtained by FARALLON for which an insurer has a duty to defend and indemnify FARALLON, and in the absence of such coverage, shall be limited to the total gross billings of FARALLON to the CLIENT under the Work Order. (ii) FARALLON'S total liability to any and all addressees, users, and relying parties, jointly and collectively, of Phase I Environmental Site Assessment Reports prepared by FARALLON shall not exceed \$1,000,000. (iii) In no event shall FARALLON be liable for consequential or indirect damages, lost profits, lost business or business opportunity or lost use of property.
- (b) HAZARDOUS SUBSTANCES: If state or federally regulated hazardous, toxic, or dangerous wastes as defined by state or federal regulations (hereinafter wastes) are encountered at the site, and if these wastes require handling, transportation, or disposal at an off-site facility, FARALLON will assist in advising the CLIENT of the CLIENT's options. However, FARALLON will not "arrange" (as defined in 42 U.S.C. 9607) for disposal of, accept title to, sign manifests for, or take control of any wastes. CLIENT shall indemnify and hold FARALLON harmless from any claims, damages, fines and fees, litigation, or expenses arising out of or in any way related to handling, transportation, and disposal of any wastes in the course of FARALLON's performance of this Agreement.
- (c) CLIENT covenants and agrees to fully defend, protect, indemnify, and hold harmless FARALLON and its employees and agents from and against each and every claim, demand, or cause of action, and any liability, cost, expense, damage or loss in connection therewith which may be made or asserted by CLIENT, CLIENT'S employee's agents, or third parties, on account of personal injury or death, or property damage to the extent caused by or arising out of the negligence or intentional actions of CLIENT, but not to the extent caused by the negligent or intentional acts of FARALLON or its employees. It is specifically and expressly understood that the indemnification provided in this paragraph constitutes a waiver by CLIENT of immunity under the Industrial Insurance Act (Title 51 RCW) to the extent that such waiver is expressly required by the laws of the state of Washington.



## ARTICLE 9.0 GENERAL PROVISIONS

**9.1 Successors and Assigns.** This Agreement shall inure to and be binding upon the legal representatives and successors and assigns of the parties hereto. Neither party shall assign, transfer, or convey this Agreement or any Work Order or any Work Change Order, or any right, title, or interest therein, or any power to execute the same, to any person, company, or corporation without the prior written consent of the other, which shall not be unreasonably withheld.

**9.2 Dispute Resolution.** All disputes relating to this Agreement where the amount in dispute is equal to or exceeds \$75,000 shall be decided by alternative dispute resolution. Upon notice of a dispute between them, the parties will mutually agree on, and will share equally the cost of, a qualified mediator, and will conduct a mediation conference in accordance with the mediator's instructions at a location in the state in which the Work is performed. If the mediation does not resolve the parties' dispute, a mutually selected arbitrator shall arbitrate the dispute. If the parties cannot agree on an arbitrator, the arbitrator shall be appointed by a court of competent jurisdiction. The arbitrator's decision shall be final and binding as if entered by a court having jurisdiction of said dispute. The parties shall share equally the cost of the arbitration and each party in an arbitration proceeding shall pay its own attorney's fees and costs incurred therein.

For those matters where the amount in dispute is less than \$75,000 the parties may litigate that dispute in the Washington state courts for King County, Washington, which shall have exclusive jurisdiction over those claims. The parties to this Agreement consent to the jurisdiction of those courts for the purpose of adjudicating claims arising from this Agreement. In the event that any dispute is resolved through the commencement of judicial proceedings, the substantially prevailing party may recover its reasonable attorney fees and costs.

**9.3 Confidentiality.** Without prior written approval by CLIENT, FARALLON shall not publish or release any information to news media or to other third parties, except as required by law, and shall exercise care to protect the confidentiality of any information disclosed to it by CLIENT or ascertained by FARALLON in connection with or as a result of any work performed pursuant to this Agreement. Unless expressly forbidden by CLIENT, FARALLON may use and publish the name and location of the project and a general description of the services provided by FARALLON in describing FARALLON's experience and qualifications to other potential clients.

**9.4 Independent Contractor.** All work performed pursuant to this Agreement, Work Order, or Work Change Order shall be performed by FARALLON as an independent contractor, and under no circumstances will FARALLON or its employees be considered employees or agents of CLIENT. CLIENT shall have no voice in the selection, discharge, supervision, or control of FARALLON's employees or representatives. Except to the extent that a particular method is specified in any plans or specifications hereunder, or in the Work Order or Work Change Order, CLIENT shall not have the right to direct or control FARALLON in the method of performance or the means of accomplishing the desired result.

**9.5 Compliance with Laws.** Each of FARALLON and CLIENT represents and warrants to the other that it is, and covenants that it will continue to be, in material compliance with all federal, state, and local laws and regulations, except as otherwise disclosed to the other in writing.



- 9.6 Modification.** All amendments, changes, and modifications to this Agreement shall be made in writing by Amendment or Addendum, and approved and executed with the same formality as this Agreement.
- 9.7 Governing Law.** This Agreement and all Work shall be governed by and interpreted in accordance with the laws of the state or other jurisdiction in which the Work is performed.
- 9.8 Survival.** The terms and conditions of Articles 2.0, 3.0, 4.0, 8.0, and 9.0 (together with any other provisions of this Agreement, any Work Order, or any Work Change Order that may be reasonably construed to survive) shall survive termination or expiration of this Agreement and any Work Order or Work Change Order.

## ARTICLE 10.0 PROJECT MANAGER / NOTICES

- 10.1 Project Manager.** FARALLON shall designate a Project Manager for the Work whose approvals and instructions shall be binding upon FARALLON, and who shall provide personal supervision to the faithful performance of the Work. The Project Manager may designate an acting Project Manager in his/her absence, as well as field coordinators and inspectors. The Project Manager will be identified on each Work Order and Work Change Order, subject to change at any time by FARALLON upon notice to CLIENT, for which email notification by FARALLON to CLIENT's representative shall be deemed sufficient.
- 10.2 Notices.** All contractual notices affecting this Agreement shall be sufficient if delivered in writing as follows:
- if to FARALLON:                   **FARALLON CONSULTING, L.L.C.**  
13555 Southeast 36<sup>th</sup> Street, Suite 320  
Bellevue, Washington 98006
- if to CLIENT:                       **CITY OF SUMNER**  
1104 Maple Street  
Sumner, Washington 98930
- 10.3 Authority.** FARALLON and CLIENT each hereby represent and warrant to the other:
- (a) That it has full corporate power and authority to enter into this Agreement and to perform its obligations hereunder;
  - (b) That the execution, delivery, and performance of this Agreement by FARALLON and Client, and the implementation by FARALLON and CLIENT of the transactions contemplated hereby, have been duly approved and authorized by all requisite corporate action of FARALLON and CLIENT; and,
  - (c) This Agreement has been duly executed and delivered by FARALLON and CLIENT and constitutes a valid and legally binding obligation of FARALLON and CLIENT, enforceable against such organization in accordance with its terms.



IN WITNESS WHEREOF, the parties hereto have signed this Agreement, made effective as of **April 15, 2026**.

**CITY OF SUMNER**

**FARALLON CONSULTING, L.L.C.**

\_\_\_\_\_  
*Signature of Authorized Representative*

\_\_\_\_\_  
*Signature of Authorized Representative*

\_\_\_\_\_  
*Printed Name*

\_\_\_\_\_  
*Printed Name*

\_\_\_\_\_  
*Title*

\_\_\_\_\_  
*Title*

\_\_\_\_\_  
*Email*

\_\_\_\_\_  
*Email*



**WORK ORDER 3993-001.001-WO 001  
CONSULTING SERVICES AGREEMENT 3993  
FARALLON CONSULTING, L.L.C.  
AND  
CITY OF SUMNER**

Project No.: 3993-001.001 Date: April 15, 2026  
 Project Title/Location: 914 Kincaid Avenue, Sumner, Washington  
 Scope of Work: As described in the Letter regarding scope of work and cost estimate to complete a Remedial Investigation-Feasibility Study-draft Cleanup Action Plan (RI-FS-dCAP) for the Sumner Texaco cleanup site at 914 Kincaid Avenue in Sumner dated April 15, 2026  
 Schedule: Commencement Date: April 15, 2026 Completion Date: TBD  
 Farallon's Project Manager: James Welles  
 Client's Project Manager: Alisa O'Haver-Ayala  
 Schedule of Charges: 2026 Schedule of Charges I  
 Total Cost Estimate: \$198,038  
 Health and Safety Plan:  Required  Not Required  
 Special Provisions/Other Information: None

This WORK ORDER is made and entered into pursuant to that certain **Consulting Services Agreement 3993** by and between the undersigned on April 15, 2026, the terms, conditions, and provisions of which are hereby incorporated herein and made a part hereof. Further, by authorizing this WORK ORDER, the Client has selected and authorized Farallon to proceed with the recommended approach described in the Scope of Work.

**CITY OF SUMNER**

**FARALLON CONSULTING, L.L.C.**

\_\_\_\_\_  
*Signature of Authorized Representative*      *Date*

\_\_\_\_\_  
*Printed Name*

\_\_\_\_\_  
*Title*

\_\_\_\_\_  
*email*

\_\_\_\_\_  
*Signature of Authorized Representative*      *Date*

\_\_\_\_\_  
*Printed Name*

\_\_\_\_\_  
*Title*

\_\_\_\_\_  
*email*

## 2026 SCHEDULE OF CHARGES I

Effective December 1, 2025

### PERSONNEL

Principal	\$335 /hour
Principal I	\$307 /hour
Principal II	\$278 /hour
Senior I	\$254 /hour
Senior II	\$249 /hour
Associate I	\$227 /hour
Associate II	\$218 /hour
Project I	\$201 /hour
Project II	\$189 /hour
Staff I	\$172 /hour
Staff II	\$155 /hour
Staff III	\$133 /hour
Technician	\$125 /hour
Senior Analyst	\$239 /hour
Associate Analyst	\$195 /hour
Project Analyst	\$173 /hour
Staff Analyst	\$162 /hour
GIS Analyst	\$196 /hour
GIS Technician	\$162 /hour
Senior CAD Technician	\$159 /hour
CAD/Graphics Technician	\$145 /hour
Technical Editor	\$140 /hour
Project Assistant	\$125 /hour
Clerical/Support	\$105 /hour

Legal Testimony and Deposition	50% premium on labor
--------------------------------	----------------------

### EXPENSES

Subcontractors (Labor and Services)	Cost + 15%
Direct Expenses	Cost + 15%
Lodging/Meals Per Diem	Cost + 15% OR \$250/day
Report Production Expenses	Cost + 15%
Vehicle Mileage	IRS rate per mile + 15%

Unless otherwise agreed, Farallon Consulting, L.L.C. reserves the right to make reasonable adjustments to rates herein.



<b><u>FIELD INSTRUMENTS AND EQUIPMENT</u></b>	<b><u>DAILY RATE</u></b>	<b><u>WEEKLY RATE</u></b>
4-Gas Meter	\$65 /day	\$260 /week
Air Gauge/Sensor Kit	\$55 /day	\$220 /week
Air Noise Level Meter	\$50 /day	\$200 /week
AS/SVE/SSD Pilot Test Kit	\$405 /day	\$1,620 /week
Bladder Pump	\$185 /day	\$740 /week
Boat	\$1,000 /day	\$4,000 /week
dGPS (Trimble Geo7x)	\$230 /day	\$920 /week
Dive Gear + 1 Tank (per diver)	\$150 /day	\$600 /week
Drop Cam (Aqua-Vu)	\$100 /day	\$400 /week
EOS Field Data Collection Unit	\$130 /day	\$520 /week
Epibenthic Pumps	\$25 /day	\$100 /week
Field Tool Kit, H.D.	\$30 /day	\$120 /week
Field Truck	\$90 + \$.75 per mile	\$360 + \$.75 per mile
Fluorometer/DO Meter	\$60 /day	\$240 /week
Forage Fish Survey + Equipment	\$50 /day	\$200 /week
Fyke Net	\$50 /day	\$200 /week
Gastec System	\$25 /day	\$100 /week
GPS Unit	\$230 /day	\$920 /week
Hand Auger and Extensions	\$60 /day	\$240 /week
Helium Detector	\$130 /day	\$520 /week
Hydroacoustic Monitoring Equipment	\$200 /day	\$800 /week
Laptop Computer	\$30 /day	\$120 /week
Level C PPE	\$90 /day	\$360 /week
Level D PPE	\$25 /day	\$100 /week
Magnetic Locator	\$90 /day	\$360 /week
Mini Air Pump	\$45 /day	\$180 /week
Peristaltic Pump	\$75 /day	\$300 /week
pH Meter	\$20 /day	\$80 /week
Photoionization Detector	\$105 /day	\$420 /week
Pipe Camera	\$190 /day	\$760 /week
Range Finder	\$15 /day	\$60 /week
Rotary Hammer	\$65 /day	\$260 /week
Sampling/Decon Kit	\$60 /day	\$240 /week
SCUBA Dive Tank (beyond 1 tank/diver)	\$10 /day	\$40 /week
Snorkel	\$95 /day	\$380 /week
Spotting Scope	\$15 /day	\$60 /week
Structure Scan Sonar	\$100 /day	\$400 /week
Surveying Equipment	\$90 /day	\$360 /week
Swing Sampler	\$15 /day	\$60 /week
Turbidity Meter	\$35 /day	\$140 /week
Underwater Video Camera (GoPro)	\$100 /day	\$400 /week



**FIELD INSTRUMENTS AND EQUIPMENT**

	<b><u>DAILY RATE</u></b>	<b><u>WEEKLY RATE</u></b>
Unmanned Aircraft System	\$290 /day	\$1,160 /week
Unmanned Aircraft System and Hi-Resolution GPS	\$690 /day	\$2,760 /week
Van Veen Grab	\$100 /day	\$400 /week
Vapor Intrusion Sampling Kit	\$60 /day	\$240 /week
Water Level Meter	\$30 /day	\$120 /week
Water Quality Test Kit	\$25 /day	\$100 /week
Whale Pump	\$50 /day	\$200 /week
XRF Scanner	\$350 /day	\$1,400 /week
YSI/Horiba Multiparameter Meter	\$150 /day	\$600 /week

**FIELD SUPPLIES**

	<b><u>UNIT</u></b>
Beach Seine Net	\$50 /each
Bladders	\$25 /each
Disposable Bailers	\$20 /each
Gastec Detection Tubes	\$25 /each
Grade Stakes (Per Bundle)	\$30 /each
Marking Spray Paint (Per Can)	\$10 /each
Padlocks	\$20 /each
Pin Flags (Per Bundle)	\$10 /each
Pole Net	\$5 /each
Rebar (3/8" x 2' each)	\$5 /each
Sediment Cores	\$15 /each
Survey Flagging (Per Roll)	\$5 /each
Tedlar Bags	\$20 /each
Tyvek Suits	\$15 /each
Vapor Pin	\$140 /each
Waste Disposal Drum	\$105 /each
Water Sample Field Filter	\$25 /each
Well Caps	\$20 /each

**EXHIBIT B**  
CITY OF SUMNER

CERTIFICATION OF COMPLIANCE WITH SUMNER MUNICIPAL CODE CHAPTER 3.30  
"E-VERIFY"

As the person duly authorized to enter into such commitment for

**Farallon Consulting, L.L.C.**

---

[Insert Company or Organization Name]

I hereby certify that the Company or Organization named herein will

(check one box below)

Be in compliance with all of the requirements of City of Sumner Municipal Code Chapter 3.30 for the duration of the contract entered into between the City of Sumner and the Company or Organization.

OR

Hire no employees for the term of the contract between the City and the Company or Organization.

---

NAME

---

TITLE

---

DATE

## EXHIBIT C

### APPENDIX II TO PART 200---CONTRACT PROVISIONS FOR NON-FEDERAL ENTITY CONTRACTS UNDER FEDERAL AWARDS

In addition to other provisions required by the Federal agency or non-Federal entity, all contracts made by the City of Sumner under federal award(s) are subject to the following provisions, as applicable.

**(A)** Contracts for more than the simplified acquisition threshold currently set at \$150,000, which is the inflation adjusted amount determined by the Civilian Agency Acquisition Council and the Defense Acquisition Regulations Council (Councils) as authorized by 41 U.S.C. 1908, must address administrative, contractual, or legal remedies in instances where contractors violate or breach contract terms, and provide for such sanctions and penalties as appropriate.

**(B)** All contracts in excess of \$10,000 must address termination for cause and for convenience by the non-Federal entity including the manner by which it will be effected and the basis for settlement.

**(C)** Equal Employment Opportunity. Pursuant to applicable federal law, federal regulations and/ or a final and binding Presidential Executive Order 11473, all federally funded construction project contractors shall ensure compliance with federal antidiscrimination laws, including the Equal Employment Opportunity regulations as currently written or subsequently modified or repealed.

**(D)** Davis-Bacon Act, as amended (40 U.S.C. 3141-3148). When required by Federal program legislation, all prime construction contracts in excess of \$2,000 awarded by non-Federal entities must include a provision for compliance with the Davis-Bacon Act (40 U.S.C. 3141-3144, and 3146-3148) as supplemented by Department of Labor regulations (29 CFR Part 5, "Labor Standards Provisions Applicable to Contracts Covering Federally Financed and Assisted Construction"). In accordance with the statute, the following language is hereby incorporated into the contract as if fully set forth therein:

Application of Uniform Guidance. If this contract involves the use, in whole or in part, of federal award(s), the following provisions (29 CFR, Subtitle A Part 5, Subpart A, § 5.5, subsections (a)(1)

– (a)(10)) shall apply:  
(1) Minimum wages.

(i) All laborers and mechanics employed or working upon the site of the work (or under the United States Housing Act of 1937 or under the Housing Act of 1949 in the construction or development of the project), will be paid unconditionally and not less often than once a week, and without subsequent deduction or rebate on any account (except such payroll deductions as are permitted by regulations issued by the Secretary of Labor under the Copeland Act ( 29 CFR part 3)), the full amount of wages and bona fide fringe benefits (or cash equivalents thereof) due at time of payment computed at rates not less than those contained in the wage determination of the Secretary of Labor which is attached hereto and made a part hereof, regardless of any contractual relationship which may be alleged to exist between the contractor and such laborers and mechanics. Contributions made or costs reasonably anticipated for bona fide fringe benefits under section 1(b)(2) of the Davis-Bacon Act on behalf of laborers or mechanics are considered wages paid to such laborers or mechanics, subject to the provisions of paragraph (a)(1)(iv) of this section; also, regular contributions made or costs incurred for more than a weekly period (but not less often than quarterly) under plans, funds, or programs which cover the particular weekly period, are deemed to be constructively made or incurred during such weekly period. Such laborers and mechanics shall be paid the appropriate wage rate and fringe benefits on the wage determination for the classification of work actually performed, without regard to skill, except as provided in § 5.5(a)(4). Laborers or mechanics performing work in more than one classification may be compensated at the rate specified for each classification for the time actually worked therein: Provided, That the employer's payroll records accurately set forth the time spent in each classification in which work is performed. The wage determination (including any additional classification and wage rates conformed under paragraph (a)(1)(ii) of this section) and the Davis-Bacon poster (WH-1321) shall be posted at all times by the

contractor and its subcontractors at the site of the work in a prominent and accessible place where it can be easily seen by the workers.

(ii)

(A) The contracting officer shall require that any class of laborers or mechanics, including helpers, which is not listed in the wage determination and which is to be employed under the contract shall be classified in conformance with the wage determination. The contracting officer shall approve an additional classification and wage rate and fringe benefits therefore only when the following criteria have been met:

(1) The work to be performed by the classification requested is not performed by a classification in the wage determination; and

(2) The classification is utilized in the area by the construction industry; and

(3) The proposed wage rate, including any bona fide fringe benefits, bears a reasonable relationship to the wage rates contained in the wage determination.

(B) If the contractor and the laborers and mechanics to be employed in the classification (if known), or their representatives, and the contracting officer agree on the classification and wage rate (including the amount designated for fringe benefits where appropriate), a report of the action taken shall be sent by the contracting officer to the Administrator of the Wage and Hour Division, U.S. Department of Labor, Washington, DC 20210. The Administrator, or an authorized representative, will approve, modify, or disapprove every additional classification action within 30 days of receipt and so advise the contracting officer or will notify the contracting officer within the 30-day period that additional time is necessary.

(C) In the event the contractor, the laborers or mechanics to be employed in the classification or their representatives, and the contracting officer do not agree on the proposed classification and wage rate (including the amount designated for fringe benefits, where appropriate), the contracting officer shall refer the questions, including the views of all interested parties and the recommendation of the contracting officer, to the Administrator for determination. The Administrator, or an authorized representative, will issue a determination within 30 days of receipt and so advise the contracting officer or will notify the contracting officer within the 30-day period that additional time is necessary.

(D) The wage rate (including fringe benefits where appropriate) determined pursuant to paragraphs (a)(1)(ii) (B) or (C) of this section, shall be paid to all workers performing work in the classification under this contract from the first day on which work is performed in the classification.

(iii) Whenever the minimum wage rate prescribed in the contract for a class of laborers or mechanics includes a fringe benefit which is not expressed as an hourly rate, the contractor shall either pay the benefit as stated in the wage determination or shall pay another bona fide fringe benefit or an hourly cash equivalent thereof.

(iv) If the contractor does not make payments to a trustee or other third person, the contractor may consider as part of the wages of any laborer or mechanic the amount of any costs reasonably anticipated in providing bona fide fringe benefits under a plan or program, Provided, That the Secretary of Labor has found, upon the written request of the contractor, that the applicable standards of the Davis-Bacon Act have been met. The Secretary of Labor may require the contractor to set aside in a separate account assets for the meeting of obligations under the plan or program.

(2) Withholding. The City of Sumner shall upon its own action or upon written request of an authorized representative of the Department of Labor withhold or cause to be withheld from the contractor under this contract or any other Federal contract with the same prime contractor, or any other federally-assisted contract subject to Davis-Bacon prevailing wage requirements, which is held by the same prime contractor, so much of the accrued payments or advances as may be considered necessary to pay laborers and mechanics, including apprentices, trainees, and helpers, employed by the contractor or any subcontractor the full amount of wages required by the contract. In the event of failure to pay any laborer or mechanic, including any apprentice, trainee, or helper, employed or working on the site of the work (or under the United States Housing Act of 1937 or under the Housing Act of 1949 in the construction or development of the project), all or part of the wages required by the contract, the (Agency) may, after written notice to the contractor, sponsor, applicant, or owner, take such action as may be necessary to cause the suspension of any further payment, advance, or guarantee of funds until such violations have ceased.

(3) Payrolls and basic records.

(i) Payrolls and basic records relating thereto shall be maintained by the contractor during the course of the work and preserved for a period of three years thereafter for all laborers and mechanics working at the site of the work (or under the United States Housing Act of 1937, or under the Housing Act of 1949, in the construction or development of the project). Such records shall contain the name, address, and social security number of each such worker, his or her correct classification, hourly rates of wages paid (including rates of contributions or costs anticipated for bona fide fringe benefits or cash equivalents thereof of the types described in section 1(b)(2)(B) of the Davis-Bacon Act), daily and weekly number of hours worked, deductions made and actual wages paid. Whenever the Secretary of Labor has found under 29 CFR 5.5(a)(1)(iv) that the wages of any laborer or mechanic include the amount of any costs reasonably anticipated in providing benefits under a plan or program described in section 1(b)(2)(B) of the Davis-Bacon Act, the contractor shall maintain records which show that the commitment to provide such benefits is enforceable, that the plan or program is financially responsible, and that the plan or program has been communicated in writing to the laborers or mechanics affected, and records which show the costs anticipated or the actual cost incurred in providing such benefits. Contractors employing apprentices or trainees under approved programs shall maintain written evidence of the registration of apprenticeship programs and certification of trainee programs, the registration of the apprentices and trainees, and the ratios and wage rates prescribed in the applicable programs.

(ii) (A) The contractor shall submit weekly for each week in which any contract work is performed a copy of all payrolls to the City if the agency is a party to the contract, but if the agency is not such a party, the contractor will submit the payrolls to the applicant, sponsor, or owner, as the case may be, for transmission to the City. The payrolls submitted shall set out

accurately and completely all of the information required to be maintained under 29 CFR 5.5(a)(3)(i), except that full social security numbers and home addresses shall not be included on weekly transmittals. Instead the payrolls shall only need to include an individually identifying number for each employee (e.g., the last four digits of the employee's social security number). The required weekly payroll information may be submitted in any form desired. Optional Form WH-347 is available for this purpose from the Wage and Hour Division Web site at <http://www.dol.gov/esa/whd/forms/wh347instr.htm> or its successor site. The prime contractor is responsible for the submission of copies of payrolls by all subcontractors. Contractors and subcontractors shall maintain the full social security number and current address of each covered worker, and shall provide them upon request to the City if the agency is a party to the contract, but if the agency is not such a party, the contractor will submit them to the applicant, sponsor, or owner, as the case may be, for transmission to the City, the contractor, or the Wage and Hour Division of the Department of Labor for purposes of an investigation or audit of compliance with prevailing wage requirements. It is not a violation of this section for a prime contractor to require a subcontractor to provide addresses and social security numbers to the prime contractor for its own records, without weekly submission to the sponsoring government agency (or the applicant, sponsor, or owner).

(B) Each payroll submitted shall be accompanied by a "Statement of Compliance," signed by the contractor or subcontractor or his or her agent who pays or supervises the payment of the persons employed under the contract and shall certify the following:

(1) That the payroll for the payroll period contains the information required to be provided under § 5.5 (a)(3)(ii) of Regulations, 29 CFR part 5, the appropriate information is being maintained under § 5.5 (a)(3)(i) of Regulations, 29 CFR part 5, and that such information is correct and complete;

(2) That each laborer or mechanic (including each helper, apprentice, and trainee) employed on the contract during the payroll period has been paid the full weekly wages earned, without rebate, either directly or indirectly, and that no deductions have been made either directly or indirectly from the full wages earned, other than permissible deductions as set forth in Regulations, 29 CFR part 3;

(3) That each laborer or mechanic has been paid not less than the applicable wage rates and fringe benefits or cash equivalents for the classification of work performed, as specified in the applicable wage determination incorporated into the contract.

(C) The weekly submission of a properly executed certification set forth on the reverse side of Optional Form WH-347 shall satisfy the requirement for submission of the "Statement of Compliance" required by paragraph (a)(3)(ii)(B) of this section.

(D) The falsification of any of the above certifications may subject the contractor or subcontractor to civil or criminal prosecution under section 1001 of title 18 and section 231 of

title 31 of the United States Code.

(iii) The contractor or subcontractor shall make the records required under paragraph (a)(3)(i) of this section available for inspection, copying, or transcription by authorized representatives of the City or the Department of Labor, and shall permit such representatives to interview employees during working hours on the job. If the contractor or subcontractor fails to submit the required records or to make them available, the Federal agency may, after written notice to the contractor, sponsor, applicant, or owner, take such action as may be necessary to cause the suspension of any further payment, advance, or guarantee of funds. Furthermore, failure to submit the required records upon request or to make such records available may be grounds for debarment action pursuant to 29 CFR 5.12.

(4) Apprentices and trainees.

(i) Apprentices. Apprentices will be permitted to work at less than the predetermined rate for the work they performed when they are employed pursuant to and individually registered in a bona fide apprenticeship program registered with the U.S. Department of Labor, Employment and Training Administration, Office of Apprenticeship Training, Employer and Labor Services, or with a State Apprenticeship Agency recognized by the Office, or if a person is employed in his or her first 90 days of probationary employment as an apprentice in such an apprenticeship program, who is not individually registered in the program, but who has been certified by the Office of Apprenticeship Training, Employer and Labor Services or a State Apprenticeship Agency (where appropriate) to be eligible for probationary employment as an apprentice. The allowable ratio of apprentices to journeymen on the job site in any craft classification shall not be greater than the ratio permitted to the contractor as to the entire work force under the registered program. Any worker listed on a payroll at an apprentice wage rate, who is not registered or otherwise employed as stated above, shall be paid not less than the applicable wage rate on the wage determination for the classification of work actually performed. In addition, any apprentice performing work on the job site in excess of the ratio permitted under the registered program shall be paid not less than the applicable wage rate on the wage determination for the work actually performed. Where a contractor is performing construction on a project in a locality other than that in which its program is registered, the ratios and wage rates (expressed in percentages of the journeyman's hourly rate) specified in the contractor's or subcontractor's registered program shall be observed. Every apprentice must be paid at not less than the rate specified in the registered program for the apprentice's level of progress, expressed as a percentage of the journeymen hourly rate specified in the applicable wage determination. Apprentices shall be paid fringe benefits in accordance with the provisions of the apprenticeship program. If the apprenticeship program does not specify fringe benefits, apprentices must be paid the full amount of fringe benefits listed on the wage determination for the applicable classification. If the Administrator determines that a different practice prevails for the applicable apprentice classification, fringes shall be paid in accordance with that determination. In the event the Office of Apprenticeship Training, Employer and Labor Services, or a State Apprenticeship Agency recognized by the Office, withdraws approval of an apprenticeship program, the contractor will no longer be permitted to utilize apprentices at less than the applicable predetermined rate for the work performed until an acceptable program is approved.

(ii) Trainees. Except as provided in 29 CFR 5.16, trainees will not be permitted to work at less than the predetermined rate for the work performed unless they are employed pursuant to and individually registered in a program which has received prior approval, evidenced by formal certification by the U.S. Department of Labor, Employment and Training Administration. The ratio of trainees to journeymen on the job site shall not be greater than permitted under the plan approved by the Employment and Training Administration. Every trainee must be paid at not less than the rate specified in the approved program for the trainee's level of progress, expressed as a percentage of the journeyman hourly rate specified in the applicable wage determination. Trainees shall be paid fringe benefits in accordance with the provisions of the trainee program. If the trainee program does not mention fringe benefits, trainees shall be paid the full amount of fringe benefits listed on the wage determination unless the Administrator of the Wage and Hour Division determines that there is an apprenticeship program associated with the corresponding journeyman wage rate on the wage determination which provides for less

than full fringe benefits for apprentices. Any employee listed on the payroll at a trainee rate who is not registered and participating in a training plan approved by the Employment and Training Administration shall be paid not less than the applicable wage rate on the wage determination for the classification of work actually performed. In addition, any trainee performing work on the job site in excess of the ratio permitted under the registered program shall be paid not less than the applicable wage rate on the wage determination for the work actually performed. In the event the Employment and Training Administration withdraws

approval of a training program, the contractor will no longer be permitted to utilize trainees at less than the applicable predetermined rate for the work performed until an acceptable program is approved.

(iii) Equal employment opportunity. The utilization of apprentices, trainees and journeymen under this part shall be in conformity with federal antidiscrimination laws, including the Equal Employment Opportunity regulations as currently written or subsequently modified or repealed.

(5) Compliance with Copeland Act requirements. The contractor shall comply with the requirements of 29 CFR part 3, which are incorporated by reference in this contract.

(6) Subcontracts. The contractor or subcontractor shall insert in any subcontracts the clauses contained in 29 CFR 5.5(a)(1) through (10) and such other clauses as the City may by appropriate instructions require, and also a clause requiring the subcontractors to include these clauses in any lower tier subcontracts. The prime contractor shall be responsible for the compliance by any subcontractor or lower tier subcontractor with all the contract clauses in 29 CFR 5.5.

(7) Contract termination: debarment. A breach of the contract clauses in 29 CFR 5.5 may be grounds for termination of the contract, and for debarment as a contractor and a subcontractor as provided in 29 CFR 5.12.

(8) Compliance with Davis-Bacon and Related Act requirements. All rulings and interpretations of the Davis-Bacon and Related Acts contained in 29 CFR parts 1, 3, and 5 are herein incorporated by reference in this contract.

(9) Disputes concerning labor standards. Disputes arising out of the labor standards provisions of this contract shall not be subject to the general disputes clause of this contract. Such disputes shall be resolved in accordance with the procedures of the Department of Labor set forth in 29 CFR parts 5, 6, and 7.. Disputes within the meaning of this clause include disputes between the contractor (or any of its subcontractors) and the contracting agency, the U.S. Department of Labor, or the employees or their representatives.

(10) Certification of eligibility.

(i) By entering into this contract, the contractor certifies that neither it (nor he or she) nor any person or firm who has an interest in the contractor's firm is a person or firm ineligible to be awarded Government contracts by virtue of section 3(a) of the Davis- Bacon Act or 29 CFR 5.12(a)(1).

(ii) No part of this contract shall be subcontracted to any person or firm ineligible for award of a Government contract by virtue of section 3(a) of the Davis-Bacon Act or 29 CFR 5.12(a)(1).

(iii) The penalty for making false statements is prescribed in the U.S. Criminal Code, 18 U.S.C. 1001.

**(E)** Contract Work Hours and Safety Standards Act (40 U.S.C. 3701-3708). Where applicable, all contracts awarded by the non-Federal entity in excess of \$100,000 that involve the employment of mechanics or laborers must include a provision for compliance with 40 U.S.C. 3702 and 3704, as supplemented by Department of Labor regulations (29 CFR Part 5). Under 40 U.S.C. 3702 of the Act, each contractor must be required to compute the wages of every mechanic and laborer on the basis of a standard work week of 40 hours. Work in excess of the standard work week is permissible provided that the worker is compensated at a rate of not less than one and a half times the basic rate of pay for all hours worked in excess of 40 hours in the work week. The requirements of 40 U.S.C. 3704 are applicable to construction work and provide that no laborer or mechanic must be required to work in surroundings or under working conditions which are unsanitary, hazardous or dangerous. These requirements do not apply to the purchases of supplies or materials or articles ordinarily available on the open market, or contracts for transportation or transmission of intelligence.

**(F)** Rights to Inventions Made Under a Contract or Agreement. If the Federal award meets the definition of "funding agreement" under 37 CFR §401.2 (a) and the recipient or sub recipient wishes to enter into a contract with a small business firm or nonprofit organization regarding the substitution of parties, assignment or performance of experimental, developmental, or research work under that "funding agreement," the recipient or sub recipient must comply with the requirements of 37 CFR Part 401, "Rights to Inventions Made by Nonprofit Organizations and Small Business Firms Under Government Grants, Contracts and Cooperative Agreements," and any implementing regulations issued by the awarding agency.

**(G)** Clean Air Act (42 U.S.C. 7401-7671q.) and the Federal Water Pollution Control Act (33 U.S.C. 1251-1387), as amended-Contracts and sub grants of amounts in excess of \$150,000 must contain a provision that requires the non-Federal award to agree to comply with all applicable standards, orders or regulations issued pursuant to the Clean Air Act (42 U.S.C. 7401-7671q) and the Federal Water Pollution Control Act as amended (33 U.S.C.

1251-1387). Violations must be reported to the Federal awarding agency and the Regional Office of the Environmental Protection Agency (EPA).

**(H)** Mandatory standards and policies relating to energy efficiency which are contained in the state energy conservation plan issued in compliance with the Energy Policy and Conservation Act (42 U.S.C. 6201).

**(I)** Debarment and Suspension (Executive Orders 12549 and 12689)-A contract award (see 2 CFR 180.220) must not be made to parties listed on the government wide Excluded Parties List System in the System for Award Management (SAM), in accordance with the OMB guidelines at 2 CFR 180 that implement Executive Orders 12549 (3 CFR Part 1986 Comp., p. 189) and 12689 (3 CFR Part 1989 Comp., p. 235), "Debarment and Suspension." The Excluded Parties List System in SAM contains the names of parties debarred, suspended, or otherwise excluded by agencies, as well as parties declared ineligible under statutory or regulatory authority other than Executive Order 12549.

**(J)** Byrd Anti-Lobbying Amendment (31 U.S.C. 1352)-Contractors that apply or bid for an award of \$100,000 or more must file the required certification. Each tier certifies to the tier above that it will not and has not used Federal appropriated funds to pay any person or organization for influencing or attempting to influence an officer or employee of any agency, a member of Congress, officer or employee of Congress, or an employee of a member of Congress in connection with obtaining any Federal contract, grant or any other award covered by 31 U.S.C. 1352. Each tier must also disclose any lobbying with non-Federal funds that takes place in connection with obtaining any Federal award. Such disclosures are forwarded from tier to tier up to the non-Federal award.

---

**SUBJECT:** Approval of the minutes from the following: April 20, 2026 regular council meeting, April 27th study session, and May 4th and May 11th council budget retreats.

**CATEGORY:** Consent

---

**BUDGET IMPACT:**

Expenditure Required: None

Within Budget Allocation: N/A

---

**ATTACHMENTS:**

1. Minutes - April 20, 2026
2. Minutes - April 27, 2026
3. Minutes - May 4, 2026
4. Minutes - May 11, 2026

**STAFF CONTACT:** Michelle Converse, City Clerk

---

**SUMMARY BACKGROUND:**

Minutes from the previous four council meetings.

<p><b>COUNCIL COMMITTEE/STUDY SESSION:</b> <b>MEETING/STUDY SESSION DATE:</b> <b>COMMITTEE RECOMMENDATION:</b></p>
--

**STAFF RECOMMENDATIONS/MOTION:**

Approve as presented.



*The city conducted this public meeting using a hybrid model, in-person and on the Zoom platform.*

Staff present: Wilson, Marquez, Ruth, Windish, Johnstone, Barry, Palmer, Steffens, Beagle, McCurdy, Littrell, and Converse

THE REGULAR MEETING OF THE SUMNER CITY COUNCIL WAS CALLED TO ORDER BY MAYOR BOWMAN AT 6:00PM.

### **CALL TO ORDER**

Pledge of Allegiance

Invocation by David Barnes

Roll Call: Elfers, Evers, Hochstatter, Kenna, Malcolm, Reinke and Wilsey

### **PROCLAMATION**

Public Operations Deputy Director Derek Barry read the 2026 Arbor Day Proclamation into the record.

### **CONSENT AGENDA**

MOVED BY ELFERS SECONDED BY KENNA TO APPROVE THE CONSENT AGENDA CONSISTING OF:

1. Approval of Councilmember Malcolm Appointment to Finance and Personnel Committee
2. Confirming Mayoral Appointment of Andy McCurdy as Chief of Police and approval of the related Employment Agreement
3. Approval of an Employment Agreement with Ryan Johnstone as the Public Operations Department Director
4. Washington Street Preservation Project – Construction Contract Award
5. Washington Street Preservation Project – Construction Management Consultant Contract Award
6. Washington Street Preservation Project – Design Consultant Amendment Approval
7. 2026 Pavement Chip Seal Application – Construction Contract Award
8. Operations Facility – Approval of Avidex Contract
9. Approval of checks and electronic payments in the amount of \$7,884,181.19.
10. Operations Facility Furniture Purchase - Bluespace Interiors

PASSED BY VOICE VOTE.

MAYOR BOWMAN THEN ADJOURNED INTO A THREE MINUTE RECESS AT 6:07PM. AT 6:10PM THE MEETING WAS RECONVENYED.

## PUBLIC HEARING

1. **Ordinance No. 2966 – Vacation of 63<sup>rd</sup> Street East and a PPW Portion of State Street**  
Mayor Bowman opened the Public Hearing at 6:09pm and called on Deputy Attorney Doug Ruth, to address the item.

With no comments from the public, Mayor Bowman closed the Public Hearing at 6:12pm.

## REGULAR BUSINESS

2. Unfinished Business  
**Resolution No. 1744 – 2027-2032 Six Year Transportation Improvement Program Annual Update.**

MOVED BY KENNA SECONDED BY ELFERS TO APPROVE RESOLUTION NO. 1744 – 2027-2032 SIX-YEAR TRANSPORTATION IMPROVEMENT PROGRAM ANNUAL UPDATE.

Courtney Littrell, Assistant Engineering Manager, addressed the item.

Since this item had a Public Hearing on April 6, 2026, there were no comments taken from the public.

Discussion ensued.

PASSED BY ROLL CALL VOTE.

1. **Public Comment**

Randall Adams, Sumner.

Trisha Maygra, Sumner.

Tina Burnett, Sumner.

2. **New Business**

- a. **Mayoral Appointment Planning Commission – Biermann**

MOVED BY HOCHSTATTER SECONDED BY ELFERS TO APPROVE THE MAYORAL APPOINTMENT OF NICK BIERMANN TO THE SUMNER PPLANNING COMMMISISON.

Community Development & Economic Director Ryan Windish addressed the item.

Discussion ensued.

Mr. Biermann thanked the Council for the opportunity to be a part of the process.

PASSED BY ROLL CALL VOTE.

- b. **Ordinance No. 2961 – Repealing the Cultural Arts Commission (Sumner Municipal Code 2.86)**

MOVED BY EVERS SECONDED BY ELFERS TO APPROVE ORDINANCE NO. 2961 – REPEALING THE CULTRUAL ARTS COMMISSION (SUMNER MUNICIPAL CODE 2.86).

Economic & Community Development Director Ryan Windish addressed the item.

Discussion ensued.

PASSED BY ROLL CALL VOTE.

c. **Ordinance No. 2962 – Forestry and Parks Commission Amendments (Sumner Municipal Code 2.87)**

MOVED BY WILSEY SECONDED BY ELFERS TO APPROVE ORDINANCE NO. 2962 – FORESTRY AND PARKS COMMISSION AMENDMENTS (SUMNER MUNICIPAL CODE 2.87)

Community & Economic Development Director Ryan Windish addressed the item.

COUNCILMEMBER HOCHSTATTER MOVED TO AMEND SECTION ONE OF ORDINANCE NO. 2962, SECTION 2.87.010, TO CHANGE THE NAME OF FORESTRY AND PARKS COMMISSION TO FORESTRY, PARKS AND ARTS COMMISSION TO BETTER REFLECT THE NEW SCOPE OF THE COMMISSIONS WORK. IF THIS AMENDMENT IS ADOPTED, THE COUNCILMEMBER WOULD RECOMMEND CODE PUBLISHING CHANGE ANY AND ALL REFERENCES OF FORESTRY AND PARKS COMMISSION TO FORESTRY, PARKS AND ARTS COMMISSION THROUGHOUT CITY CODE. SECONDED BY ELFERS.

Discussion ensued.

Nick Biermann spoke.

THE AMENDMENT PASSED BY ROLL CALL VOTE.

ORDINANCE 2962 PASSED AS AMENDED BY ROLL CALL VOTE.

d. **Ordinance No. 2963 – Historic Preservation Commission Amendments (Sumner Municipal Code 2.95)**

MOVED BY KENNA TO APPROVE ORDINANCE NO. 2963 – HISTORIC PRESERVATION COMMISSION AMENDMENT (SUMNER MUNICIPAL CODE 2.95) SECONDED BY EVERS.

Community & Economic Development Director Ryan Windish addressed the item.

Community members who addressed the Council during comments -

Randall Adams

Tina Burnett

Nick Biermann

Councilmember discussion ensued.

City Attorney Marquez cleared up some confusion regarding the ordinance. The Design Commission will now be tasked with Historic Preservation.

Councilmember discussion continued.

PASSED BY ROLL CALL VOTE.

e. **Ordinance No. 2965 – 2026 Commission Schedule Amendment**

MOVED BY REINKE TO APPROVE ORDINANCE NO. 2965 – 2026 COMPENSATION SCHEDULE AMENDMENT. SECONDED BY COUNCILMEMBER EVERS

Deputy City Administrator Jeff Steffens addressed the Council.

Randall Adams spoke.

PASSED BY ROLL CALL VOTE.

### 3. Reports

#### a. Council

Councilmember Wilsey congratulated Nick Biermann on his appointment. She ended her remarks by reminding everyone to shop local and upcoming events.

Councilmember Kenna congratulated Nick Biermann. Congratulated the incoming Chief of Police Andy McCurdy. He reported on the Finance Committee.

Councilmember Malcolm spoke about some upcoming meetings. He ended his comments by congratulating Nick Biermann.

Deputy Mayor Elfers reminded the viewers the Community Summit is coming up on April 28<sup>th</sup>, at Calvary Community Church. He appreciated the public comment from Trisha Megra. He congratulated Andy McCurdy on his upcoming promotion. He ended his comments by highlighting his new favorite restaurant, Pura Brasa.

Councilmember Evers agreed, Pura Brasa is a very good restaurant. He mentioned a couple of Rotary activities, the 100<sup>th</sup> Anniversary and Honors Night, celebrating the tops students in the high schools.

Councilmember Reinke congratulated Nick Biermann. He updated on the previous week's meetings he attended.

Councilmember Hochstatter thanked Trisha Megra for her comments on preschool. He thanked two founding members of the Arts Commission Donna Hardtke and Sue Larson. Arts is very dear to his heart and he appreciates the City's commitment to Arts. It's a big part of our community! Congratulated the new police Chief Andy McCurdy.

#### b. City Administrator

##### **Upcoming Policy Issues:**

- April 27<sup>th</sup> – Study Session
- Biosolids Modernization Project Debt Issuance
- YMCA Update and Services Agreement Amendment
- Battery Energy Storage Systems (BESS) 1.0 Review
- May 4<sup>th</sup> – Regular Council Meeting cancelled for Budget Retreat
- May 11<sup>th</sup> – Study Session cancelled for Budget Retreat
- May 18<sup>th</sup> – Regular Council Meeting

##### **Personnel Issues:**

Earlier tonight you approved the Mayoral appointment of Andy McCurdy to Chief of Police. Andy has over 30 years in law enforcement, and has served as Sumner's Deputy Chief of Police since August 2021. He has extensive experience in criminal investigations, police administration and employee wellness. He is a proven leader that is respected both internally and externally by our community partners.

With the promotion of Andy, separate competitive promotional processes were conducted resulting in Loren Houselog being promoted to Deputy Chief, Justin Gregon to Lieutenant and Geoff Boone to Sergeant. All three of these promotions are well deserved and each is uniquely qualified for their new positions.

These promotions mark a historic milestone in our Police Department's History. All four employees will be promoted next Monday, with their official swearing in ceremony being held at 4:30 here in the Chambers. Council and the public are invited to attend.

Brad Moericke's retirement will be celebrated at a public open house on May 27<sup>th</sup>. More information will be distributed when we get closer. McCurdy, DC Houselog, Lt. Gregson, Sgt. Boone.

**Miscellaneous:**

• **LAHAR DRILL/SUMMIT**

Thursday morning, the City will be participating in a regional lahar evacuation exercise. The event includes all schools in the Sumner Bonney Lake School District, as well as the Orting and Puyallup communities and schools. Schools in Sumner will practice evacuating the schools in the event of a lahar. This will affect traffic on main routes, especially on Valley Avenue, Main Street, and 160th Street. Please add extra time and be ready to use creative routes. We know it will impact your travel, but it's worth keeping all our students prepared. If you want to know more about a lahar, geologists will be hosting a breakout session at the Community Summit. It's free to attend, coming up next week on April 28<sup>th</sup>. We'll also host a breakout session too. Sign up online – we have the link on our website.

c. **Mayor**

Mayor Bowman spoke about the following: WSDOT work, her upcoming Coffee with Carla on Friday, April 24 and last Parks and Arbor Day. She thanked the Parks staff and Parks & Forestry Commission to their commitment to keeping our parks and public spaces beautiful and a natural multi-tool for urban living.

**EXECUTIVE SESSION**

There was none tonight.

**ADJOURNMENT**

With no additional business before the council, the Mayor adjourned the meeting at 7:31pm, Councilmembers agreed.

ATTEST:

\_\_\_\_\_  
Michelle Converse, CMC, City Clerk

\_\_\_\_\_  
Carla S. Bowman, Mayor



Staff present: Wilson, Marquez, Windish, Kosa, Steffens, Raymond, McCurdy, Walker

Councilmembers present: Evers, Elfers, Hochstatter, Kenna, Malcolm, Reinke, Wilsey

THE MEETING WAS CALLED TO ORDER AT 6:00PM BY MAYOR BOWMAN.

### **STUDY SESSION BUSINESS**

1. 2026 Water/Sewer Revenue Bond Update  
*Chief Financial Officer Cassandra Raymond*
2. YMCA Annual Update and 2013 Service Agreement Amendment  
*City Administrator Jason Wilson and Gordon Family YMCA Executive Director Jenna Lehman*
3. Battery Energy Storage Systems (BESS) Ordinance 2.0 – Joint Presentation  
*Associate Planner Chrissanda Walker and other local agencies*

### **CITY ADMINISTRATOR REPORT**

#### **AGENDA SETTING**

1. Council Meeting Agenda Calendar
2. Council Committee Meeting Agenda Calendar

### **EXECUTIVE SESSION**

#### **ADJOURNMENT**

At 8:29pm, Mayor Bowman adjourned the meeting.

---

Michelle Converse, City Clerk

Attest:

---

Carla S. Bowman, Mayor



The May 4, 2026, Council Budget Retreat began at 1pm.

All Councilmembers were present –

Bowman, Elfers, Evers, Hochstatter, Kenna, Malcolm, Reinke and Wilsey

Staff present –

Wilson, Marquez, Beagle, Kosa, Steffens, Converse, Johnstone, Windish, McCurdy, Raymond and Barry

The afternoon consisted of presentations on the following topics -

**AGENDA**

- 1:00 - 2:15 Leadership Dynamics with Dr. Donna VanNatten
- 2:15 - 2:30 Break
- 2:30 - 3:15 Overview of Existing Plans – Keeping Our Vision in Focus
- 3:15 - 4:00 Strategic Plan Development
- 4:00 - 7:00 2027-2028 Budget
  - Financial Policies
  - Fund Uses
  - Process Review
  - Known Cost Increases
  - Alternate Revenue Options
  - Policy / Accounting Changes

The Retreat ended at 7pm.

---

Michelle Converse, City Clerk

Attest:

---

Carla S. Bowman, Mayor



The May 11, 2026, Council Budget Retreat began at 1pm.

All Councilmembers were present –

Bowman, Elfers, Evers, Hochstatter, Kenna, Malcolm, Reinke and Wilsey

Staff present –

Wilson, Marquez, Beagle, Kosa, Steffens, Converse, Johnstone, Windish, McCurdy, Raymond, O’Haver-Ayala, Baker and Barry

The afternoon consisted of presentations on the following topics -

**AGENDA**

1:00 - 1:30 1st Session Recap / Questions

1:30 - 2:30 Staffing History | Capacity | Requests

2:30 - 6:30 Major Initiatives

- Existing Library Property
- Animal Sheltering
- Existing Operations Facility
- Heritage Park
- Bennet Park
- Bill Heath Sports Complex

6:30 - 7:00 Recap / Questions

The Retreat ended at 7:02pm.

\_\_\_\_\_  
Michelle Converse, City Clerk

Attest:

\_\_\_\_\_  
Carla S. Bowman, Mayor

---

**SUBJECT:** Ordinance No. 2966 - Vacation of 63rd Street East and a Portion of State Street

**CATEGORY:** Ordinance

---

**BUDGET IMPACT:**

Expenditure Required: None

Within Budget Allocation: N/A

---

**ATTACHMENTS:**

1. Ordinance No. 2966 - Vacation of 63rd Street East and a Portion of State Street

**STAFF CONTACT:** Doug Ruth, Deputy City Attorney

---

**SUMMARY BACKGROUND:**

The City is proposing to vacate 63rd Street East and a portion of State Street. The roadways are directly in front of the Sumner Waste Water Treatment Facility. The proposal is intended to facilitate both the installation of a main security gate to the entrance to the facility and simplify permitting of any improvements to the facility. Since a portion of the parking lot is a right-of-way, the city is required to perform additional steps when altering the portions of the facility that fall within the right-of-way. And a main security gate will eliminate the need to have several security gates on the property. Because the City will retain ownership of the vacated property, the City sewer and water utility lines that are in the right-of-way will remain accessible to the City. No utility easement is required as part of the roadway vacation.

The City Council held a public hearing on this street vacation on April 20, 2026.

---

<p><b>COUNCIL COMMITTEE/STUDY SESSION:</b> Public Works Committee <b>MEETING/STUDY SESSION DATE:</b> 3/3/2026 <b>COMMITTEE RECOMMENDATION:</b> Do Pass</p>
--

**STAFF RECOMMENDATIONS/MOTION:**

A motion to approve Ordinance No. 2966 and all other related and necessary documents Vacating 63rd Street East and a Portion of State Street, all within the City's Waste Water Treatment Facility grounds, in a form as approved by the City Attorney.

**ORDINANCE NO. 2966  
CITY OF SUMNER, WASHINGTON**

**AN ORDINANCE OF THE CITY COUNCIL OF THE CITY OF SUMNER, WASHINGTON, VACATING 63<sup>rd</sup> STREET EAST AND A PORTION OF STATE STREET IN SUMNER, AS MORE PARTICULARLY SET FORTH HEREIN.**

**WHEREAS**, the portion of the public right-of-way to be vacated is more particularly described and depicted on Exhibit A and is herein referred to as the “Right of Way;” and

**WHEREAS**, the City of Sumner, which is the owner of the property adjacent to the Right of Way, submitted a petition to vacate the Right-of-Way and the City represents more than two-thirds of all ownership of the property abutting the Right of Way; and

**WHEREAS**, the Right-of-Way consists of both 63<sup>rd</sup> Street East, which is approximately five hundred by sixty feet, and a 100-foot long portion of State Street. 63<sup>rd</sup> Street East lies immediately in front of the Sumner Wastewater Treatment Facility; and

**WHEREAS**, the Right-of-Way contains public utilities, which will remain in the City’s control upon vacation of the Right-of-Way as the roadways adjoin the City’s property; and

**WHEREAS**, no portion of the Right of Way abuts a body of fresh or salt water as contemplated under RCW 35.79.035; and

**WHEREAS**, the highest and best use of the Right of Way is for general municipal use as vacation will allow the City of Sumner to expand the Waste Water Treatment Facility and more easily develop the site, including consolidating the secure entrances to various portions of the facility; and

**WHEREAS**, the Sumner City Council adopted Resolution No. 1747 affixing April 20, 2026, at the hour of 6:00 pm, at Sumner City Hall, 1104 Maple Street, Sumner, as the time and place for a public hearing on the petition to vacate pursuant to RCW 35.79.030, with access to said public hearing being available by ZOOM; and

**WHEREAS**, at the time and place fixed, the public hearing did occur and all requirements of state law and city code have been duly taken and carried out.

**NOW THEREFORE, THE CITY COUNCIL OF THE CITY OF SUMNER, WASHINGTON DOES ORDAIN AS FOLLOWS:**

**Section 1. Vacation.** That the Right of Way described in Exhibit A, which is attached and made part hereof, is hereby vacated.

**Section 2. Surrender.** The Right of Way so vacated, is surrendered and attached to the immediately abutting property, and all right or title of the City and of the public, in and to the Right of Way so vacated, subject to an easement for utilities and services, shall and does

vest in the abutting property owners as provided by RCW 35.79.040. The City is the owner of the adjacent property and has not incurred expense in acquiring or maintaining the Right of Way, and therefore the City Council finds that it is reasonable and appropriate to vacate it without compensation.

**Section 3.** **Recording with the County Auditor.** Pursuant to RCW 35.79.030, a certified copy of this ordinance shall be recorded by the City Clerk in the officer of the Pierce County Auditor.

**Section 4.** **Corrections by City Clerk or Code Reviser.** Upon approval of the city attorney, the city clerk and the code reviser are authorized to make necessary corrections to this ordinance, including the correction of clerical errors; ordinance, section, or subsection numbering; or references to other local, state, or federal laws, codes, rules, or regulations.

**Section 5.** The Mayor is hereby authorized to implement such administrative procedures as may be necessary to carry out the directions of this legislation

Passed by the City Council and approved by the Mayor of the City of Sumner, Washington, at a regular meeting thereof on the \_\_\_\_ day of \_\_\_\_\_, 2026

\_\_\_\_\_  
Carla S. Bowman, Mayor

Attest:

\_\_\_\_\_  
Michelle Converse, City Clerk

Approved as to form:

\_\_\_\_\_  
Andrea Marquez, City Attorney

## RIGHT OF WAY LEGAL DESCRIPTIONS AND DEPICTIONS

### EXHIBIT "A"

Owner: City of Sumner  
63<sup>rd</sup> Street East (Harrison St) & State Street  
**Right of Way Vacation**

#### LEGAL DESCRIPTION OF RIGHT OF WAY VACATION

THAT PORTION OF THE SOUTHEAST QUARTER OF THE SOUTHEAST QUARTER OF SECTION 23, TOWNSHIP 20 NORTH, RANGE 4 EAST, WILLAMETTE MERIDIAN DESCRIBED AS FOLLOWS:

THE 63RD STREET EAST (HARRISON STREET) RIGHT OF WAY LYING WEST OF WASHINGTON STATE ROUTE 410.

TOGETHER WITH THAT PORTION OF STATE STREET DESCRIBED AS FOLLOWS:

BEGINNING AT THE INTERSECTION OF THE NORTH MARGIN OF 63RD STREET EAST (HARRISON STREET) AND THE SOUTHEAST MARGIN OF STATE STREET;  
THENCE NORTH 8.85 FEET ALONG SAID SOUTHEAST MARGIN TO THE BEGINNING OF A 27.35 FOOT RADIUS CURVE CONCAVE SOUTHEASTERLY;  
THENCE NORTHEASTERLY ALONG THE ARC OF SAID CURVE AND SAID SOUTHEAST MARGIN A DISTANCE OF 27.66 FEET, THROUGH A CENTRAL ANGLE OF 57°57'00";  
THENCE NORTHWESTERLY 60.00 FEET ALONG A LINE RADIAL TO SAID CURVE TO THE BEGINNING OF A NON-TANGENT 87.35 FOOT RADIUS CURVE CONCAVE SOUTHEASTERLY, BEING CONCENTRIC TO SAID 27.35 FOOT RADIUS CURVE;  
THENCE SOUTHWESTERLY ALONG THE ARC OF SAID CURVE A DISTANCE OF 88.35 FEET, THROUGH A CENTRAL ANGLE OF 57°57'00";  
THENCE SOUTH 8.85 FEET TO THE INTERSECTION OF SAID NORTH MARGIN OF 63RD STREET EAST (HARRISON STREET) AND THE NORTHWEST MARGIN OF SAID STATE STREET;  
THENCE EAST 60.00 FEET TO THE POINT OF BEGINNING.

SITUATE IN THE COUNTY OF PIERCE, STATE OF WASHINGTON.

CONTAINS 34,307 SQUARE FEET, MORE OR LESS.



SE 1/4 SE 1/4, SEC 23, T20N, R4E, W.M.

WHITE RIVER

STATE ROUTE 410

85' R=87.35'  
 $\Delta=57^{\circ}57'00''$

STATE ST

8.85'

60.00'

L=27.66' R=27.35'  
 $\Delta=57^{\circ}57'00''$

8.85'

P.O.B.

63RD ST E (HARRISON ST)

RIGHT OF WAY VACATION  
84,307± SQ. FT.

CITY OF SUMNER  
TAX PARCEL NO. 4250001393

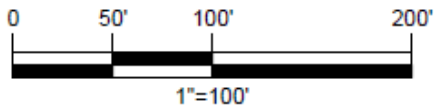

**CITY OF SUMNER**  
63RD ST E (HARRISON ST) & STATE ST  
RIGHT OF WAY VACATION

---

**Gray & Osborne, Inc.**  
CONSULTING ENGINEERS  
1130 RAINIER AVENUE SOUTH, SUITE 300  
SEATTLE, WASHINGTON 98144 (206) 284-0860

---

**SUBJECT:** Appointment to Sumner Lodging Tax Advisory Committee - Crick

**CATEGORY:** Motion

---

**BUDGET IMPACT:**

Expenditure Required: None

Within Budget Allocation: N/A

---

**ATTACHMENTS:**

1. Sumner Lodging Tax Advisory Commission Application - Crick

**STAFF CONTACT:** Carmen Palmer, Communications Director

---

**SUMMARY BACKGROUND:**

Most of Sumner's lodging tax funding (5% tax) continues to go to Pierce County for allocation. Sumner still receives a smaller 2% shared sales tax that is the State Transient Rental tax. In order to use this funding, Sumner must still follow State rules to form a Lodging Tax Advisory Committee (LTAC) to provide feedback to the Council. Per RCW 67.28,

1. One member shall be an elected official of the city of Sumner, who shall serve as chair; (Deputy Mayor Elfers as selected by Council with the committee selection process)
  2. Two members shall be representatives of businesses required to collect tax under this chapter;
  3. Two members shall be persons involved in activities authorized to be funded by revenue received under this chapter.
- The members must be confirmed annually.

Mayor Bowman recommends appointing Kylie Crick, Regional Director of Sales & Marketing for Sumner's Holiday Inn Express and Candlewood Suites, to fill one of the representatives of persons representing properties collecting the tax. This would be her first appointment to this committee.

---

**COUNCIL COMMITTEE/STUDY SESSION:**

**MEETING/STUDY SESSION DATE:**

**COMMITTEE RECOMMENDATION:**

**STAFF RECOMMENDATIONS/MOTION:**

Confirm mayoral appointment of Kylie Crick to the Sumner Lodging Tax Advisory Committee.



# COMMISSION APPLICATION

Thank you for your interest in serving on a City of Sumner commission. We value the contributions that volunteers make in keeping Sumner a great place. This application will help us better understand your background. **Please fill out electronically or print clearly.**

I am interested in serving on the following Commission:

- CULTURAL ARTS     DESIGN     FORESTRY & PARKS     SALARY  
 CIVIL SERVICE     LODGING TAX     PLANNING

Name: Kylie Crick Contact Phone: [Redacted]

Address: [Redacted]

Email: [Redacted]

**Occupation** (if retired, please indicate former occupation or profession):

Regional Director of Sales and Marketing for Sumner Hotels LLC

**Education:** Some college

**Professional and / or Community Involvement:**

Regional Director of Sales and Marketing for the two hotel properties in Sumner - Holiday Inn Express and the Candlewood Suites.

**Why are you interested in serving on this commission?**

I'm interested in better understanding the tourism and lodging landscape in the city and how hotel operations intersect with local tourism initiatives

**Have you previously served on a City commission?**       Yes       No

**If yes, which one(s):** \_\_\_\_\_

*Please note that all information on this form becomes public information when submitted.*

Return completed form to City of Sumner, 1104 Maple Street, Sumner, WA 98390

OR email: [michellec@sumnerwa.gov](mailto:michellec@sumnerwa.gov)

\_\_\_\_\_  
Applicant' Signature

(if submitted electronically, we will obtain your signature later in the process)

---

**SUBJECT:** Appointment to the Forestry, Parks & Arts Commission - Thomas

**CATEGORY:** Motion

---

**BUDGET IMPACT:**

Expenditure Required: None

Within Budget Allocation: N/A

---

**ATTACHMENTS:**

1. Application - Thomas

**STAFF CONTACT:** Ryan Windish, Community & Economic Development Director

---

**SUMMARY BACKGROUND:**

Mayor Bowman is seeking confirmation of new Forestry, Parks & Arts Commission member, Devin Thomas.

The Sumner Forestry, Parks & Arts Commission consists of up to twelve (12) members who are appointed by the Mayor and confirmed by the City Council. The members are to be selected without respect to political affiliations and shall serve a four-year (4) term without compensation.

Devin lives in Sumner with his family and is co-owner of a pilates studio in downtown Sumner. He is interested in serving on the commission because of his background in visual design and the importance that the influence of art and design have on a community.

---

**COUNCIL COMMITTEE/STUDY SESSION:**

**MEETING/STUDY SESSION DATE:**

**COMMITTEE RECOMMENDATION:**

**STAFF RECOMMENDATIONS/MOTION:**

Confirm appointment of Devin Thomas to the Forestry, Parks & Arts Commission to a term expiring April 30, 2030.

**From:** [Michelle Converse](#)  
**To:** [Lana Hoover](#); [Ryan Windish](#)  
**Subject:** FW: Anonymous User completed Commission Application  
**Date:** Wednesday, December 10, 2025 12:50:45 PM

---

---

**From:** Sumner Connects <notifications@engagementhq.com>  
**Sent:** Wednesday, December 10, 2025 12:50 PM  
**To:** Michelle Converse <MichelleC@sumnerwa.gov>  
**Subject:** Anonymous User completed Commission Application

 **External:** Use caution with links/attachments.

Anonymous User just submitted the survey Commission Application with the responses below.

**I am interested in serving on the following:**

Arts & Culture Commission

---

**Name:**

Devin Thomas

---

**Phone Number:**

[REDACTED]

---

**Email Address**

[REDACTED]

---

**Address:**

[REDACTED] Sumner Wa 98390

---

**Occupation (if retired, please indicate former occupation or profession):**

Senior Brand Designer - Pilates Studio Co-Owner

---

**Education:**

**Professional or community involvement:**

I am currently working as a co-owner of the The Press Pilates here in town with my wife Courtney. I am also a full time freelance graphic/visual designer.

---

**Why are you interested in serving on this commission?**

I'm interested in serving on this commission because I believe design and art play a powerful role in shaping how a community feels, functions, and connects. My background in visual design has shown me how thoughtful creativity can strengthen identity, foster belonging, and create spaces that inspire people in their everyday lives. I want to contribute my skills to help our community grow in a meaningful and beautiful way. I want to serve my community the best way I know how through design and art.

---

**Have you previously served on a City of Sumner commission?**

No

---

|

---

**SUBJECT:** Appointment to the Forestry, Parks & Arts Commission - Mathews

**CATEGORY:** Motion

---

**BUDGET IMPACT:**

Expenditure Required: None

Within Budget Allocation: N/A

---

**ATTACHMENTS:**

1. Application - Mathews

**STAFF CONTACT:** Ryan Windish, Community & Economic Development Director

---

**SUMMARY BACKGROUND:**

Mayor Bowman is seeking confirmation of new Forestry, Parks & Arts Commission member, Annmarie Mathews.

The Sumner Forestry, Parks & Arts Commission consists of up to twelve (12) members who are appointed by the Mayor and confirmed by the City Council. The members are to be selected without respect to political affiliations and shall serve a four-year (4) term without compensation.

Annmarie lives in Sumner and has served on the Cultural Arts Commission since 2020. She believes that encouraging the arts in a community is important to create an enriching and beautiful environment for all. She plans to use her love of the arts and her personal experience to benefit the work of the commission and the people of the city.

---

<p><b>COUNCIL COMMITTEE/STUDY SESSION:</b> <b>MEETING/STUDY SESSION DATE:</b> <b>COMMITTEE RECOMMENDATION:</b></p>
--

**STAFF RECOMMENDATIONS/MOTION:**

Confirm appointment of Annmarie Mathews to the Forestry, Parks & Arts Commission to a term expiring April 30, 2030.

APPLICATION

Anonymous User just submitted the survey Commission Application with the responses below.

**I am interested in serving on the following:**

Arts & Culture Commission

---

**Name:**

Annmarie Mathews

---

**Phone Number:**

[REDACTED]

---

**Email Address**

[REDACTED]

---

**Address:**

[REDACTED] Sumner, WA 98390

---

**Occupation (if retired, please indicate former occupation or profession):**

Retired. Most recently worked as Volunteer Coordinator for Step By Step

---

**Education:**

High school diploma 1987

---

**Professional or community involvement:**

I currently serve on the Sumner Cultural Arts Commission. I volunteer regularly with the local organization Step By Step to help encourage healthy families in our community.

---

**Why are you interested in serving on this commission?**

I believe encouraging the arts in a community is important in helping create an enriching and beautiful environment for all its citizens. In serving on the commission I hope I am using my love of the arts and my experience in working with groups of people to benefit our city in this way.

---

**Have you previously served on a City of Sumner commission?**

Yes

---

**If yes, which one(s):**

The Cultural Arts Commission since 2020

---

|

---

**SUBJECT:** Heritage Park Phase 3 & 4 Consultant Contract Amendment

**CATEGORY:** Motion

---

**BUDGET IMPACT:**

Expenditure Required: \$644,739.00

Within Budget Allocation: Yes

---

**ATTACHMENTS:**

1. Amendment 5

**STAFF CONTACT:** Drew McCarty, Assistant Engineering Manager

---

**SUMMARY BACKGROUND:**

For the Main Street Vision Project, JETT Landscape Architecture + Design worked with the City from 2022 to 2023 to reimagine Reuben Knoblauch Heritage Park as a more active and functional community space. In 2024, JETT completed design for Heritage Park and Hops Alley, including 60% construction documents for the Heritage Park Event Building. In 2026, the City completed construction of Heritage Park Phase 2 and Hops Alley.

JETT Landscape Architecture + Design, Inc. has submitted an amendment to provide professional design services to advance Heritage Park Phase 3 and the Phase 4 Event Building to 100% construction documents. This work includes preparation of permit-ready and bid-ready plans, specifications, and cost estimates necessary to support public bidding. The amendment also includes final design coordination across disciplines and incorporation of prior construction feedback and any updated City requirements.

The City has negotiated an amount of \$644,739.00. This amendment increases the total contract value to \$2,857,954.00.

---

**COUNCIL COMMITTEE/STUDY SESSION:** Public Works Committee

**MEETING/STUDY SESSION DATE:** 4/21/2026

**COMMITTEE RECOMMENDATION:** Do Pass

**STAFF RECOMMENDATIONS/MOTION:**

A motion approving a supplement to JETT's Consultant Services Contract for the Heritage Park Phase 3 & 4 Project, increasing the contract amount by \$644,739.00 to a total authorized amount not-to-exceed \$2,857,954.00, and authorizing the Mayor and City Administrator to execute any and all documents necessary to effectuate the amendment, substantially in a form as approved by the City Attorney.



## AMENDMENT NO. 5

NAME OF CONSULTANT, CONTRACTOR OR VENDOR: **Jett Landscape Architecture + Design, Inc.**

CONTRACT NAME & PROJECT NUMBER: **Heritage Park & Alley Master Plan (W-22-04)**

ORIGINAL AGREEMENT DATE: **October 17, 2022**

This Amendment is made between the City and the above-referenced Consultant, Contractor or Vendor and amends the original Contract/Agreement and all prior Amendments. All other provisions of the original Contract/Agreement or prior Amendments not inconsistent with this Amendment shall remain in full force and effect. For valuable consideration and by mutual consent of the parties, Consultant, Contractor or Vendor’s work is modified as follows:

**1.** Section I of the Agreement, entitled “Description of Work,” is hereby modified to add additional work or revise existing work as follows:

In addition to work required under the original Agreement and any prior Amendments, the Consultant, Contractor or Vendor shall:

**See Exhibit A**

**2.** The contract amount and time for performance provisions of Section II “Time of Completion,” and Section III, “Compensation,” are modified as follows:

Original Contract Sum, <i>including applicable WSST</i>	<b>\$215,000.00</b>
Net Change by Previous Amendments <i>including applicable WSST</i>	<b>\$1,998,215.00</b>
Current Contract Amount <i>including all previous amendments</i>	<b>\$2,213,215.00</b>
Current Amendment Sum	<b>\$644,739.00</b>
Applicable WSST Tax on this Amendment	<b>N/A</b>
Revised Contract Sum	<b>\$2,857,954.00</b>

Original Time for Completion (insert date)	<b>12/31/2024</b>
Revised Time for Completion under prior Amendments (insert date)	<b>12/31/2026</b>
Add'l Days Required (±) for this Amendment	<b>365</b> calendar days
Revised Time for Completion (insert date)	<b>12/31/2027</b>

In accordance with Section XIV E of the Contract/Agreement, the Contractor, Consultant or Vendor accepts all requirements of this Amendment by signing below, by its signature waives any protest or claim it may have regarding this Amendment, and acknowledges and accepts that this Amendment constitutes full payment and final settlement of all claims of any kind or nature arising from or connected with any work either covered or affected by this Amendment, including, without limitation, claims related to contract time, contract acceleration, onsite or home office overhead, or lost profits. This Amendment, unless otherwise provided, does not relieve the Contractor, Consultant or Vendor from strict compliance with the guarantee and warranty provisions of the original Agreement.

All acts consistent with the authority of the Agreement, previous Amendments (if any), and this Amendment, prior to the effective date of this Amendment, are hereby ratified and affirmed, and the terms of the Agreement, previous Amendments (if any), and this Amendment shall be deemed to have applied.

The parties whose names appear below swear under penalty of perjury that they are authorized to enter into this Amendment, which is binding on the parties of this contract.

**IN WITNESS, the parties below have executed this Amendment, which will become effective on the last date written below.**

<p><b>CONSULTANT, CONTRACTOR OR VENDOR:</b></p> <p>By: _____ (signature)</p> <p>Print Name: _____</p> <p>Its _____ (Title)</p> <p>DATE: _____</p>	<p><b>CITY OF SUMNER:</b></p> <p>By: _____ (signature)</p> <p>Print Name: <u>Carla S. Bowman</u></p> <p>Its <u>Mayor</u> (Title)</p> <p>DATE: _____</p>
<p><b>CITY OF SUMNER:</b></p> <p>By: _____ (signature)</p> <p>Print Name: <u>Jason Wilson</u></p> <p>Its <u>City Administrator</u> (Title)</p> <p>DATE: _____</p>	<p><b>APPROVED AS TO FORM:</b></p> <p>_____ Sumner City Attorney</p>



Landscape Architecture + Design

Orinda Office  
2 Theatre Square  
Suite 218  
Orinda, CA 94563  
925.254.5422 P

Seattle Office  
3445 California Avenue SW  
Suite A  
Seattle, WA 98116  
206.947.6869 P

**AMENDMENT PROPOSAL FOR PROFESSIONAL SERVICES**

---

DATE: January 27, 2025 *(Revised 03/14/26)*

TO: Drew McCarty, CACM  
Assistant Engineering Manager  
City of Sumner  
1104 Maple Street  
Sumner, WA 98390

PROJECT: Reuben A. Knoblauch Heritage Park, Event Building & Hops Alley – **Amendment 05**

CLIENT: City of Sumner Parks Department

CC: Derek Barry, Community Services Manager  
Alisa O’Haver-Ayala, City Engineer

Dear Drew,

JETT Landscape Architecture + Design, Inc. is pleased to have the opportunity to submit the following amendment proposal to the City of Sumner for Landscape Architectural Services for the Reuben A. Knoblauch Heritage Park, Event Building for Phase 3 and 4 of construction & bid documentation, in the City of Sumner, Washington.

Our team is excited to continue building on our work in the downtown core with the City in these next phases of documentation and permit. Feel free to contact me anytime to discuss this proposal, or if any of the above requires further clarification.

Sincerely,  
Jett Landscape Architecture + Design

A handwritten signature in black ink, appearing to read "TBronk".

Todd L. Bronk, Principal  
WRLA #1056

## GENERAL SCOPE OF WORK

---

The following Scope of Work is based upon the City of Sumner’s Master Plan for Heritage Park Phased construction documentation for Phase 3 – 100% Plans, completed 12/30/2024 and the Phase 4 – Heritage Park Event Building – 50% Plans completed in 11/30/2024.

**Exhibit A** provides the overall scope areas Phase 3 and 4 of the park and event building.

**Exhibit B** provides a task-based schedule for the project with an anticipated completion date for all work.

**Exhibit C** provides a breakdown of fees, including sub-consultants for the overall scope of this proposal.

All work will be in close collaboration with the City of Sumner and JETT’s design team assembled for this project per the following detailed scope of services.

The project consists of the following tasks / scopes of work:

1. Phase 3 - Heritage Park Documentation
2. Phase 4 - Heritage Park Event Building (HPEB) Bid Documentation (broken down per City request)
  - (1) Plan Documentation
  - (2) Bid Specifications
  - (3) Advanced Renderings for Building Only
3. Project management

The scope of work will include the following disciplines | professional design firms:

1. Landscape Architecture | JETT
2. Civil Engineering & Site Estimation | JMJ
3. Electrical Engineering | GFT
4. Structural Engineering | Swenson Say Faget
5. Survey | Truland
6. Security | Security Solutions
7. AV System Design | Avidex
8. Architecture. Building Project Management | TCF Architecture - (refer to Exhibit D)
  - o Structural Engineering | PCS
  - o Mechanical, Electrical, Plumbing Engineering | GFT
  - o Estimation (Building) | RC Cost Group
  - o Envelope Consultant | ABBAE
  - o Hardware | Adams Consultant
  - o Coatings | TM Coatings
  - o Acoustical | Tenor

## **DETAIL SCOPE OF WORK**

---

The JETT team will provide services in accordance with tasks and deliverables outlined below. The JETT team will work collaboratively with the City of Sumner (City) and in the following phases:

### **Task 1: Heritage Park – Phase 3 Bid Documentation**

---

#### **1.1 Update Site Survey – Heritage Park Site**

1. JETT will provide an electronic update to the Site Survey for the development of the Phase 3 and 4 bid documents based on the recently completed work at Heritage Park in 2025 and the temporary installation of the interim park.
  - A. Limits would be roughly to outer curb lines.
  - B. This is for above-ground features only so no measurements inside manholes, catch basins, etc.
  - C. This also does not include any costs for a utility subcontractor to come out and mark conductible utilities such as power, telephone, etc.
  - D. Keep in mind that our original scope included full topo within the roads but was limited to only utilities within the park area. A full topographic survey of the park this time to get all the new hardscape grades for connections in Phase 3 documentation.

#### **1.2 100% Construction Documents**

1. Duration: Refer to Schedule, Exhibit B
2. Description: 100% Construction Documents are intended to be an opportunity to develop and issue Permit Drawings for any elements (stage structure, light poles, etc.) required, provide correction and comment Responses necessary to obtain local building permit(s) based on the previously completed Phase 3, 90% construction documents issued in December 2024. During this phase the Team will produce final details for construction, include lessons learned from the construction of phase 2 in 2025, and transfer WSDOT front-end specifications and project specifications to CSI format to allow both Phase 3 and Phase 4 to bid to a single contractor. These documents will be provided in a digital review set, for the City to review, comment and respond prior to the Bid Document phase.
  - A. The Drawings will advance the sheets delivered at the 90% Construction Document level to final 100% Construction documents, permit ready, bid ready plans and specifications.
  - B. A comment response document will be provided for all building permit comments and responses for coordination and record utilizing a Bluebeam mark up or spreadsheet.

Advanced MEP Services provided by per city request have been included in the 100% Construction Documentation and include design and coordination with City staff and installation teams. The base scope and fee structure currently includes the following:

- C. **Stage and Event Lawn AV Design:** The basic site infrastructure only scope to support the A/V is included with the basic service. If a complete site PA and A/V system design is required, this would require additional coordination and design with Technology personnel.
- D. **CCTV:** The basic site infrastructure only scope to support the site CCTV coverage is included with the basic service. If a complete installed CCTV system design is required, this would require additional coordination and design with Technology personnel.
- E. **PSE Follow-up and Coordination of Service Transformer:** Lead the coordination with PSE to coordinate and finalize required offsite 3-phase power underground extension to support the Heritage Park building service transformer. This additional scope will also include further coordination to apply for variance for an underground transformer.

3. Disciplines:
  - A. Landscape Architecture
  - B. Civil Engineering
  - C. Electrical Engineering
  - D. Structural Engineering
  - E. Security
  - F. AV System Design
4. Meetings:
  - A. (1) Client Meeting Every (2) Weeks
  - B. (1) Team Meeting Every (2) Weeks
  - C. (1) VE Meeting (if necessary)
5. Deliverables:
  - A. Meeting Agendas
  - B. Meeting Notes
  - C. Outdoor Mechanical / Electrical systems design & coordination.
    - i. AV at Stage and Park areas
    - ii. AV controls and connection into Event Building – conduit only placement by JETT (City consultant to finalize design)
    - iii. Wi-Fi at Park areas in coordination with Event Building
    - iv. CCTV locations, routing, and design – conduit only placement by JETT (City consultant to finalize design)
    - v. Coordination / Design of Service transformer for the building and site electrical needs. Includes exploration of underground system in vault with PSE.
    - vi. Routing / coordination of all park lighting controls into Event Building (Phase 4)
  - D. 100% Submittal:
    - i. 100% Construction Drawings (Permit ready)
      1. Structural Calculations
      2. Stormwater Report
      3. CSI Specifications
      4. Front End Specs
      5. Cost Estimate Update
    - ii. The base bid of the proposal assumes the following permits may be required for bid document development and will be confirmed by City of Sumner
      1. Civil Site Permit
      2. Fire Permit (site)
      3. Phase 4 permit coordinated with site elements (as needed)
      4. Right of Way permit (as needed)
      5. Building Permit – Stage Element / Lighting (if needed)
  - E. Permit Correction/Response Round 1
  - F. Permit Correction/Response Round 2
  - G. QA/QC Documentation on 100% Submittal

### 1.3 Bid Documents

1. Duration: Refer to Schedule, Exhibit B
2. Description:
  - A. The Team will work during this phase to ensure that the Bid Document package is complete such that the City may issue it for Public Bids. Resolution of Permit and Review

comments will be incorporated. The final bid plans will incorporate all building permits and city review comments into a bid ready package.

3. Disciplines:
  - A. Landscape Architecture
  - B. Civil Engineering
  - C. Electrical Engineering
  - D. Structural Engineering
  - E. Security | Security Solutions
  - F. AV System Design | Avidex
4. Meetings:
  - A. (1) Client Meeting Every (2) Weeks
  - B. (1) Team Meeting Every (2) Weeks
5. Deliverables:
  - A. Meeting Agendas
  - B. Meeting Notes
  - C. Markups on City Front End Specs
  - D. Draft Bid Document Submittal:
    - i. CSI Specifications Book:
      1. Front End Specs
      2. CSI Specifications
    - ii. Cost Estimate Final update
  - E. Bid Document Submittal
  - F. Record of Decision Matrix

*End of Task 1 Base Scope of Services*

## **Task 2: Heritage Park Event Building – Phase 4 Bid Documents**

---

### **2.1 100% Construction | Permit | Bid Plans**

Duration: Refer to Schedule, Exhibit B

#### **1. Project Restart and Coordination:**

- A. Description: (TCF) Regrouping of the design team and restart design activities. Because previous staff on the project are working on other projects its likely new staff will be involved and will need to get up to speed on the project by reviewing the documents, getting familiar with materials etc., regrouping meetings with JETT, consultants and the City in preparation for document completion.
- B. Meetings:
  - i. (1) Client Meeting
  - ii. (1) Team Meeting

#### **2. Council Chambers Document update:**

- A. Description: (TCF, PCS, GFT) The design team will adjust the existing council chambers drawings based on the edits provided by the City shown below. Including, floor plans, elevations, finish schedules, MEP, Structural, and low voltage and other related impacted items. This assumes that there are no changes to the building footprint and exterior wall locations and is only interior adjustments.
- B. Meetings:
  - i. (2) Client Meeting
  - ii. Up to (2) Team Meeting
- C. Deliverables:
  - i. Progress plans for design update
  - ii. Final plans for design update, confirmed by client team.

#### **3. Site Design Coordination:**

- A. Description: (TCF, JETT, JMJ, GFT) Building design team final coordination with site civil and landscape designs, stormwater management, site furniture, entry points, and shared indoor / outdoor facilities.
- B. Meetings:
  - i. (1) Client Meeting
  - ii. Up to (2) Team Meeting
- C. Deliverables:
  - i. Background updates to JETT for Phase 3 site based on final building updates.

#### **4. Roof landscape Design:**

- A. Description: (JETT, TCF) Finalize design and documentation of the roof and balcony area in coordination with landscape architect team, including specifications. Design will include coordination of hardscape materials, exterior furniture, access to green roof for maintenance, and guard railings (TCF).
- B. Meetings:
  - i. (1) Client Meeting
  - ii. Up to (2) Team Meeting
- C. Deliverables:
  - i. Final backgrounds in Revit to JETT, including building roof profiles, drainage locations, and parapet conditions.
  - ii. Plans and details for roof terrace coordinated with the building documents.

**5. Permit Submittal and responses:**

- A. Description: (All) Prepare and submit building permit application and documents. This also includes some time for responses to the AHJ’s building permit comments. Site related permitting plans and coordination with landscape and civil in phase 3 documentation.
- B. Meetings:
  - i. (1) Client Meeting
  - ii. Up to (2) Team Meeting
- C. Deliverables: (TCF lead)
  - i. Building Permit Submittal with any required site plans from Phase 3 included.
  - ii. Permit comment response document to City comments (up to 2 rounds)
  - iii. Updated permit plan documents

**6. 100% Construction | Bid Ready Plans:**

- A. Description: (All) Develop drawings to 100% CD level in preparation for bidding the project based on final permit comments and City approval of all comments.
- B. Meetings:
  - i. (1) Client Meeting
  - ii. Up to (3) Team Meeting
- C. Deliverables:
  - i. 100% Construction Plans coordinate
  - ii. 100% Construction estimate

**7. Post Submittal Miscellaneous Efforts:**

- A. Description: (TCF) This is to cover any discussions, meetings and coordination between 100% Construction documents and bidding.
- B. Meetings:
  - i. As needed
- C. Deliverables:
  - i. Updated plans as needed.

**8. HPEB Management Reserve Fund:**

- A. Description: (TCF) Based on conversations with the city there is the possibility of additional adjustments elsewhere in the building. This is meant to cover those efforts. This is an estimate and the actual fee needed for any changes is unknown.

**2.2 Bid Specifications (HPEB)**

- 1. Description: Prepare bid level specifications based on the 50% CD specifications prepared for the Event Building in 2024 in CSI format.
  - A. Review and respond to client comments on prior specifications at 50% CD.
  - B. Meeting(s) with City to confirm any final product, finishes, etc. in preparation for Draft Bid Specification deliverable.
  - C. Review and respond to client comments on Draft Specifications and prepare a response presentation to the City for approval to move forward with final Bid Specifications.
  - D. Prepare Bid Specifications and collaborate on front-end specification items with City staff.
- 2. Meetings:
  - A. (3) Client Meetings
- 2. Deliverables:
  - A. Draft Bid Specifications
  - B. Final Bid Specifications

### **2.3 Advanced Building Renderings**

1. Duration: Refer to Schedule, Exhibit B
2. Description:
  - A. Model Clean up and Material Placement for Heritage Park and Event Building.
    - i. Update interior models to represent current materials, colors, and finish of elements in collaboration with the final specification documentation.
    - ii. Update site models with updated park design representing materials, spaces, and details per specifications of the Phase 3 documentation package
  - B. Animation
    - i. Develop coordinated animation of interior and exterior renderings for the following spaces:
      1. Interior floors
      2. Transition spaces
      3. Exterior rooms (Play area, Event Lawn / stage, Main Street Plaza, and Festival Alley (Hops Alley)
      4. Develop daily animation and event animation.
    - ii. Utilizing a completed model from the Task 1 renderings, create a draft animation to share with the City for comments and input.
    - iii. Update final animation per City comments, add final entourage, furniture, and lighting effects. Assume 1 round of review by City for animation.
    - iv. Present final animation to client / owner and prepare a full size and reduced file size (for website viewing).
4. Meetings:
  - A. (2) Client Meetings
5. Deliverables:
  - A. Draft Animation presentation
  - B. Final Animation presentation, large and small file format.

*End of Task 2 Base Scope of Services*

### **Task 3: Project Management (JETT)**

---

#### **3.1 Project Management**

3. Management of project tasks, schedule, milestones.
4. Project Management
  - C. Client Meetings
    - i. Meeting Agendas
    - ii. Meetings Minutes / record of discussions and decisions.
  - D. Detailed master project schedule with monthly updates
  - E. Project progress reports included with monthly invoices
  - F. Changes to schedule, deliverables, and tasks throughout the life of the project including management of project contingency budget as part of the overall fee.
5. Team management
  - A. Contracting, insurance, and administrative needs surrounding team contracts, invoices, and scheduling.
  - B. Collection of invoices, payments, and distribution of payment.

#### **3.2 Management contingency**

1. Project contingency will consist of a fund of approximately 5% of the overall fee for the project to allow for unknowns in the current scope of work, significant changes in scope or schedule at the request of the client or project needs during the life of the project.

This contingency will also be a repository for any unused fees (from scope not completed under contract in each task) that can be redistributed to the project team as needed during the proposed project schedule timeline by JETT.

**FEES AND EXPENSES**

Fees for the above services will be provided on a Time and Materials basis and invoiced monthly based upon hourly rates and time expended on each task/phase of work. The fees for base services include all sub-consultant fees are summarized below. Refer to breakdown of fees in Exhibit E.

**Base Services**

Task 1.0: Heritage Park – Phase 3 Documents	\$ 250,209
Task 2.0: Heritage Park Event Building	\$ 310,690
2.1: Heritage Park Event Building – Phase 4 Documents	\$ 261,110
2.2: Heritage Park Event Building – Phase 4 Bid Specifications	\$ 31,275
2.3: Heritage Park Event Building – Phase 4 Advanced Renderings	\$ 18,305
Task 3.0: Project Management	\$ 56,840
Project Management Contingency	\$ 25,000
<b>Total Base Services Fee</b>	<b>\$ 642,739</b>
<b>Reimbursable Expenses (Budget Estimate)</b>	<b>\$ 2,000</b>
<b>Total Fee</b>	<b>\$ 644,739</b>

Reimbursable expenses are included in the above fees and will be billed on a time and materials basis as described under Schedule of Hourly Rates and Expenses. The above amount is for budgeting purposes and may be subject to modification within the total fee amount. Please see Assumptions and Schedule of Hourly Rates and Expenses below.

**ADDITIONAL SERVICES**

Fees for the following optional services are not included in the above Scope of Work and Fees and may be negotiated on a task-by-task basis or at stated hourly rates. JETT will provide a detailed estimate of fees and expenses for Client approval prior to commencing with these services and utilize the management contingency as part of Task 4: Project Management if funds are available.

- |   |                    |
|---|--------------------|
| 1. Change in overall schedule of the project as outlined in Exhibit B     | Time and Materials |
| 2. Additional permit submittals not identified in the above scope of work | Time and Materials |
| 3. Additional advanced graphics / renderings not identified above         | Time and Materials |

**SCHEDULE OF HOURLY RATES (JETT)**

Refer to attached Exhibit D

**ASSUMPTIONS**

1. Building Program: The building program is established through the 11/2024 50% Plans and is not intended to have major design changes outside of the council chambers updates in the scope of work above.
2. Schedule & Durations:
  - a. Bid Documents for Tasks 1-3 (Heritage Park Phase 3 and Phase 4, Heritage Park Event Building) will be completed by 12/31/2026. Time extensions may result in a request for additional services.

3. Regular Meetings:
  - a. Regular City/Consultant Team meetings will be held once every two weeks.
  - b. Regular Consultant Team meetings will be held once every two weeks.
  - c. Regular City/Consultant Team meetings and Regular Consultant Team meetings may be combined.
4. Bid/Spec Format:
  - a. Heritage Park Phase 3 specifications will be completed in CSI format.
  - b. Heritage Park Phase 4 - HPEB specifications will be completed in CSI format.
  - c. The City will provide front end specs in CSI format to be used as a template by the team. Edits to front end specs will be completed by the JETT team.
5. Separate Work:
  - a. Contaminated Soils Assessments, Environmental Assessments/Reports, and Contaminated Soil Management Plan (Measures for Handling/Disposal of Contaminated Soils will be completed by others separate from this scope and contract.
    - i. The City will provide updates and documentation of the progress to the JETT team.
  - b. Groundwater Monitoring is already in place and will continue to be monitored by others separate from this scope and contract.
    - i. The City will provide updates and documentation of the progress to the JETT team.
6. SEPA:
  - a. Completed as part of Amendment 02
7. Permitting:
  - a. The JETT team will author and electronically submit permit submittals including drawings, specifications and forms. The following are included:
    - i. Building Permit Submittals (City of Sumner)
    - ii. PSE Application
    - iii. Fire Department Review
  - b. No Public Works submittals or reviews are included.
8. City Review/Permit Comments will be consolidated into a single document or document set (for example a spreadsheet and a drawing set markup) for each review.
9. City to provide Arborist report for existing trees including health assessments and survey locations if required for design / planning services.
10. Submittals for each task, 1-2, shall be prepared and administered as individual packages. Further splitting of drawings into separate packages not identified in the above scope of services is not included.
11. Unless otherwise notified by City of Sumner (City), acceptance of the above proposal is for Base Services only.
12. JETT will provide services in accordance with the above Scope of Work and Fees which shall be made a part of any agreement between JETT and City of Sumner (City) and both party's responsibilities and duties shall be as agreed upon under any such agreement.
13. Reimbursable expenses shown above are for budgeting purposes only. JETT will notify City for authorization of additional expenses if required.

#### **EXCLUSIONS TO THE SCOPE OF WORK**

---

Services not included in the above Scope of Work and fees are outlined below. Some services not performed by the JETT team may be contracted through them.

1. Professional services beyond those identified in base services as described above, including arborist reports (provided by City of Sumner), traffic engineering, etc.

2. Meetings with agencies, regulatory entities, or stakeholder groups outside the above base scope of services.
3. Modifications or revisions to drawings once the Owner has approved them.
4. Coordination and processing of submittals to jurisdictional agencies outside those listed in the above base services.
5. Design of water features, pools and spas beyond Design Development.

#### **INFORMATION AND/OR SERVICES TO BE PROVIDED BY OTHERS**

---

The following information or services are required for the performance of work, and are not included in the above scope of services and fees:

1. Environmental Services (contaminated soils, groundwater monitoring, critical areas)
2. Geotechnical Services (utilize prior Geotechnical documents completed in Phase 2)
3. Cultural Resources
4. Traffic Engineering

#### **ESTIMATED WORK SCHEDULE**

---

Refer to attached Exhibit B – Project Schedule

## EXHIBIT 'A'

### Scope of work areas

(from Heritage Park Master Plan Phasing Plan)

- Phase 2 will be completed in January 2026 and surveyed to confirm final elevations and geometry installed in the field during the 2025 construction of Phase 2.
- Phase 3 includes all site area, include area shown in Phase 4, adjacent to the building, including parking and right of way documentation.
- Phase 4 scope of work is contained to the building and MEP connections 5' outside of the building envelope.
- All plans (and phases of work) are assumed to be permitted under a single document / permit plans / City comment process for the site and building phases congruently.



**EXHIBIT 'B'**  
**Project Schedule**

City of Sumner TCMP - Amendment 05 Project Schedule Estimate		2026															
		May	June	July	August	September	October	November	December	January							
		WK-1	WK-2	WK-3	WK-4	WK-1	WK-2	WK-3	WK-4	WK-1	WK-2	WK-3	WK-4	WK-1	WK-2	WK-3	WK-4
1.0	<b>Project Management</b> Project Management																
2.0	<b>Heritage Park - Phase 3 - Park Site Bid Documents</b> 100% CD Draft Set 100% CD Set (building permit set) City Review Period IFC Set																
3.0	<b>Heritage Park - Phase 4 - Building Bid Documents</b> Project Startup & Coordination Council Chambers Update & Roof Design Building Permit Set City Review Period IFC Set																

\*\* Architectural Background Set Coordination  
Draft 100% CD Set Coordination & QC

Note: Final schedule dependant on consultant availability. Final schedule will be determined once proposal approved by client

## **EXHIBIT 'C'**

### **Breakdown of consultant & sub-consultant fees**

**Sumner Town Center Master Plan - AMD 05**

Updated: April 2026



	Fees per Task	JETT LA+D	JMJ Civil	TCF Arch	GFI	Structural	Security	Audio/Visual	Survey
<b>Town Center Master Plan</b>									
1.0	Park Site - Phase 3 - Building Permit & Bid	\$250,209.00	\$98,604.00	\$0.00	\$34,500.00	\$24,000.00	\$1,440.00	\$15,385.00	\$8,400.00
2.1	HPEB - Phase 4 - Building Permit & Bid plans	\$261,110.00	\$0.00	\$232,360.00	\$0.00	\$0.00	\$5,250.00	\$23,500.00	\$0.00
2.2	HPEB - Phase 4 - Bid Specifications	\$31,275.00	\$0.00	\$16,660.00	\$0.00	\$0.00	\$0.00	\$13,115.00	\$0.00
2.3	HPEB - Phase 4 - Building Advanced Renderings	\$18,305.00	\$0.00	\$18,305.00	\$0.00	\$0.00	\$0.00	\$0.00	\$0.00
3.0	Project Management	\$56,840.00	\$0.00	\$0.00	\$0.00	\$0.00	\$0.00	\$0.00	\$0.00
	<b>Base Fees per Consultant</b>	<b>\$126,220.00</b>	<b>\$98,604.00</b>	<b>\$267,325.00</b>	<b>\$34,500.00</b>	<b>\$24,000.00</b>	<b>\$6,690.00</b>	<b>\$52,000.00</b>	<b>\$8,400.00</b>

Total JETT fee	\$126,220.00
Total Consultant fee	\$491,519.00
JETT Management Contingency	\$25,000.00
Reimbursables	\$2,000.00
<b>Total Fee</b>	<b>\$644,739.00</b>

**EXHIBIT 'D'**

**Subconsultant scope of work Task 2.1 (HPEB Plan Documents)**

August 29, 2025

Todd L. Bronk  
 Principal  
 JETT Landscape Architecture + Design  
 3445 California Avenue SW, Suite A  
 Seattle, WA 98116

**RE: CITY OF SUMNER – HERITAGE PARK EVENTS BUILDING**  
**TCF Project No. 2023-025**  
**100% CONSTRUCTION DOCUMENTS PROPOSAL**

Thank you for the opportunity to continue with the Heritage Park Event Building project. The TCF design team has been asked to complete the documents proposal for completing the documents from the current level (approximately 80%) to 100% Construction documents. Below is our proposal for the described scope.

1. Project Restart and Coordination: (TCF) Regrouping of the design team and restart design activities. Because previous staff on the project are working on other projects its likely new staff will be involved and will need to get up to speed on the project by reviewing the documents, getting familiar with materials etc, regrouping meetings with JETT, consultants and the City in preparation for document completion.
2. Council Chambers Document update: (TCF, PCS, BCE) The design team will adjust the existing council chambers drawings based on the edits provided by the City shown below. Including, floor plans, elevations, finish schedules, MEP, Structural, and low voltage and other related impacted items. This assumes that there are no changes to the building footprint and exterior wall locations and is only interior adjustments.

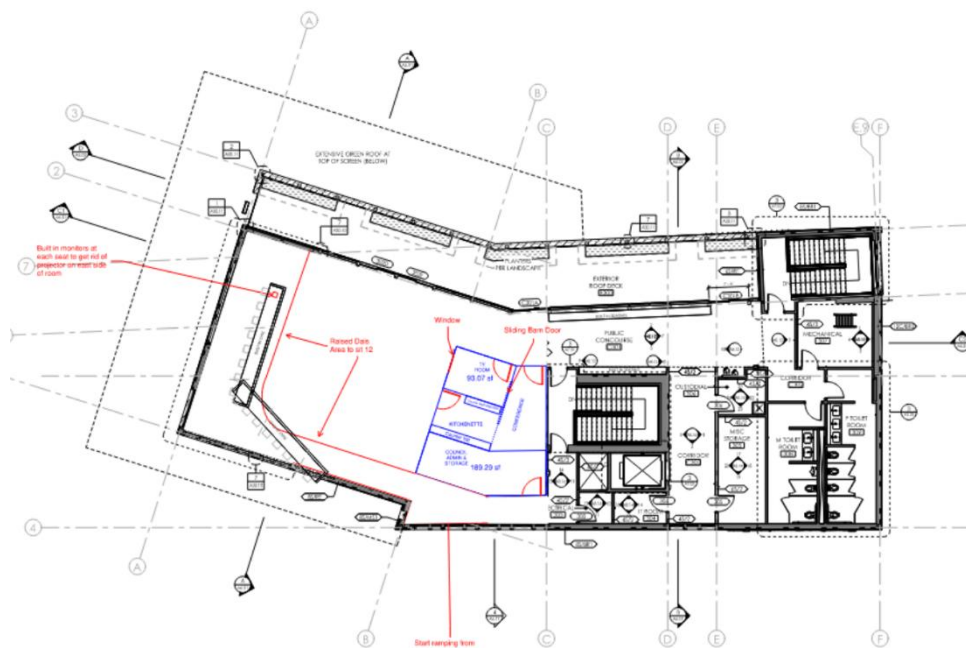

3. Site Design Coordination: (TCF, BCE) Building design team final coordination with site civil and landscape designs.

4. Jett Roof landscape Design: Jett to finalize design and documentation of the roof and balcony area landscape design.
5. Permit Submittal and responses: (All) Prepare and submit building permit application and documents. This also includes some time for responses to the AHJ's building permit comments. Site related permitting
6. 100% Construction Documents: (All) Develop drawings to 100% CD level in preparation for bidding the project.
7. Post Submittal Miscellaneous Efforts: (TCF) This is to cover any discussions, meetings and coordination between 100% Construction documents and bidding.
8. Management Reserve Fund: Based on conversations with the City there is the possibility of additional adjustments elsewhere in the building. This is meant to cover those efforts. This is an estimate and the actual fee needed for any changes is unknown.

Schedule:

- Approximately 2 months duration from NTP

Exclusions:

- Renderings (See separate proposal)
- CD phase specifications (See separate proposal)
- Bidding and construction
- Public Outreach
- Other items not specifically called out in this proposal

**COMPENSATION SUMMARY**

Phase	TCF	PCS	BCE	JETT	ABBAE	Adams	Tenor	RCCG
100% Construction Documents	\$132,680	\$27,500	\$41,150	\$7,500	\$3,000	\$500	\$1,000	\$9,030
Management Reserve	\$10,000							
<b>Total Fee</b>								<b>\$232,360</b>

Sincerely,

Mark Hurley, AIA  
 TCF Architecture  
 Principal

TASK NO.	PROJECT TASKS	TCF Architecture Architecture / Planning				Other Team Members (Contracted under TCF)							TOTALS
		Principal In Charge	Sr. Designer/ Sr. Architect	Arch 2	Project Coord.	PCS (Structural)	BCE (MEP)	JETT (Landscape Architect)	ABBAE (Envelope)	Adams Consulting (Hardware)	Tenor (Acoustics)	RCCG (Cost Estimating)	

Construction Documents 80% - 100% Completion													
	Project Restart and Coordination	2	12	16	10	\$0	\$0	\$0	\$0	\$0	\$0	\$0	
	Council Chamber document updates	2	14	50		\$8,000	\$6,000	\$0	\$0	\$0	\$0	\$0	
	Site design coordination	0	40	24		\$19,500	\$35,150	\$7,500	\$3,000	\$500	\$1,000	\$9,030	
	Permit Submittal and responses	0	12	30	4								
	100% Construction Documents	12	190	350									
	Post CD Submittal Miscellaneous Efforts	2	18	26	6	\$0	\$0	\$0	\$0	\$0	\$0	\$0	
	ESTIMATED HOURS OR FEES	18	286	496	20	\$27,500	\$41,150	\$7,500	\$3,000	\$500	\$1,000	\$9,030	
	HOURLY RATE	\$350.00	\$190.00	\$140.00	\$130.00	See Consultant Letters							
	ESTIMATED FEES	\$6,300	\$54,340	\$69,440	\$2,600								
	<b>SUBTOTAL</b>	<b>\$132,680</b>				<b>\$27,500</b>	<b>\$41,150</b>	<b>\$7,500</b>	<b>\$3,000</b>	<b>\$500</b>	<b>\$1,000</b>	<b>\$9,030</b>	<b>\$222,360</b>
	<b>SUBTOTAL PER TEAM MEMBER - ALL TASKS</b>	<b>\$132,680</b>				<b>\$27,500</b>	<b>\$41,150</b>	<b>\$7,500</b>	<b>\$3,000</b>	<b>\$500</b>	<b>\$1,000</b>	<b>\$9,030</b>	<b>\$222,360</b>
	REIMBURSABLE EXPENSE BUDGETS	\$0				\$0	\$0	\$0	\$0	\$0	\$0	\$0	\$0
	<b>SUB CONSULTANT SUBTOTALS</b>					<b>\$27,500</b>	<b>\$41,150</b>	<b>\$7,500</b>	<b>\$3,000</b>	<b>\$500</b>	<b>\$1,000</b>	<b>\$9,030</b>	<b>\$89,680</b>
	TCFA MARKUP ON CONSULTANT SERVICES (0%)	N/A				\$0	\$0	\$0	\$0	\$0	\$0	\$0	\$0
	<b>TOTAL PER TEAM MEMBER - ALL TASKS</b>	<b>\$132,680</b>				<b>\$27,500</b>	<b>\$41,150</b>	<b>\$7,500</b>	<b>\$3,000</b>	<b>\$500</b>	<b>\$1,000</b>	<b>\$9,030</b>	<b>\$222,360</b>
	<b>TOTAL ESTIMATED HOURLY FEE BUDGETS and REIMBURSABLE EXPENSES</b>												<b>\$222,360</b>

April 7, 2025

TCF Architecture  
125 North I Street  
Tacoma, WA 98403

ATTN: Mark Hurley

RE: *Additional Service for Sumner Heritage Parks Events Building  
100% Construction Documents*

Dear Mark:

Thank you for this opportunity to propose our additional services for the Sumner Heritage Parks Events Building in Sumner, Washington. On October 31, 2024, we provided your office with 60% construction documents and calculations with the intent to submit these drawings for a permit. After this submission, the project was put on hold. The city is requesting to restart this project and to provide 100% Construction Documents.

The remainder of the project includes coordination and meetings with the entire design team, providing internal quality control, coordinating final designs, review specifications, and resubmit the permit drawings and calculations as required.

We have many outstanding items that were not designed or coordinated as the schedule was accelerated to provide 60% construction documents last October. These items include but are not limited to dimensioning, canopy design and coordination, elevator coordination, fall restraint support design, coordinating exterior cladding details, detailing of structural elements, and collaboration of mechanical supports and openings, to name a few. The City Council chamber may be redesigned, but changes to the superstructure are not anticipated. We will review a new cost estimate due to the delay in schedule.

We assume that no other design changes are being proposed than what is noted above. We are excluding significant deductive or additive alternates that would require significant design or alterations to our drawings. We have designed the building under the 2021 IBC. It is our assumption that the building will be permitted using this Building Code. We assume that the schedule to provide the 100% construction documents will not include any additional lapse in schedule once the project begins. We are excluding the design of the screening at the exterior columns and have assumed that this element is a bidder design element. If additional changes are made to these assumptions, we reserve the right to request additional services as warranted.

TCF Architecture  
Mark Hurley  
*Additional Service for Sumner Heritage Parks Events Building  
100% Construction Documents*

The following are our additional services for the revised MACC and in addition to our original contract.

Additional Service

• Council Chamber Changes	\$ 8,000
• Cost Estimate Review	\$ 1,000
• 100% Construction Documents	<u>\$18,500</u>
<b>Total</b>	<b>\$27,500</b>

Billing will be on a percentage of completion basis. The fee amount may be modified only with prior written approval if the scope of services is changed.

Thank you for this opportunity to be of continued service. If there are any questions regarding this proposal, please feel free to call. We look forward to hearing from you.

Very truly yours,

PCS STRUCTURAL SOLUTIONS



Luke Heath, S.E.  
Associate Principal

LAHjcl  
24-346

Accepted by:

\_\_\_\_\_  
Signature Date

\_\_\_\_\_  
Printed Name/Title

Billing Address:  
\_\_\_\_\_

Phone: \_\_\_\_\_ Fax: \_\_\_\_\_





April 10, 2025

TCF Architecture  
902 N Second Street  
Tacoma, WA 98403

Attn: Mark Hurley

**RE: City of Sumner Heritage Park Event Center – 100% Bidding Documents M & E Fees**

Dear Mark,

We are pleased that you have included BCE Engineers on the team for this project. We look forward to working with you to finish this project. BCE proposes to take our previous (~60% design set) and provide mechanical and electrical plans, specifications and coordination with the design team, the City of Sumner, and the governing officials as necessary to finish the project to 100% design documents for bidding purposes.

The mechanical systems will consist of HVAC, DDC control system, and plumbing. The scope of the mechanical utilities work is limited to storm, waste and domestic water within five feet of the building. All else is considered outside the scope of our work, including the design of any grease interceptors, oil/water separators and sand sediment filtration tanks. Mechanical will also update equipment selection to meet the new refrigerant types and coordinate vented refrigeration pipe shafts with the team.

The electrical systems will consist of power, lighting, and low voltage systems. The low voltage systems considered basic services fire alarm, intrusion alarm systems, and data network communication infrastructure.

Support of the Revit (3D) effort for this project is included within the basic services fee structure with the exception of plumbing which will be drafted in AutoCAD. We will limit Revit model updates to once every two weeks throughout the design process. Any requirements to support greater design elements per submittal than required by the B101 guideline or a requirement to support increased model updates will result in additional fees beyond basic services. The Revit version should remain the same version as the original design. Any requirement to upgrade to a newer version of Revit will also require additional work and fees beyond basic services.

Basic services are based on a MACC of \$11.7 million dollars, using Schedule B of the State A&E fee schedule as a basis produces a fee percent of 7.87%. The electrical, mechanical, and plumbing value is currently estimated by RC Cost Group to be \$2,601,292. BCE’s calculated fee and is broken down as follows:

We stopped the original work at 60% of our original fee (which we has calculated as 69% of the full state fee calculation). We estimate that it will take \$26,549.50 in fees to complete to 100% bidding documents (plans and specifications). In addition, you requested that we propose and allotment for the council chambers redesign and time to cover permit submittal and responses. Please see the following breakdown:

100% CDs	\$26,549.50
Council Chamber Redesign	\$6,000.00
Permit Submittal and Responses	\$2,100.00

Basic Services to finish the design through 100% CD Fee: **\$34,649.50**

## Additional Extra Services, Options and Exclusions:

1. ~~Confirmed Set Drafting: In the past we have been asked to issue a new set of drawings after award of contract that includes all of the addenda items. We will draft all addenda items onto the plans, update the specifications, re-plot all the drawings and re-print the specifications. To do this work we propose a fixed fee of \$2,580.~~
2. Fire Sprinklers: This service was an added service in our original proposal and some of the work was completed already. Some time will be needed to revisit the design and finish to 100% CDs. BCE proposes to provide riser/device diagrams, coordinate PIV, FDC, and water service with the civil engineer, and provide performance level specifications. We propose to provide the above scope of work for a **fixed fee of \$1,500.**
3. ~~Washington State Energy Code (WSEC) Total System Performance Ratio (TSPR) C403.1.1: For some HVAC systems a Total System Performance Ratio (TSPR) analysis is not required. For the HVAC systems where a TSPR analysis is required, we will have additional design effort. We will have to provide an online energy model comparing the energy consumption and carbon emissions of the HVAC system to a standard reference as detailed in the WSEC (envelope levels and lighting energy are ignored). The TSPR calculation needs to be performed early in design to assure the system can meet the requirements for a “passing grade”, then again for final WSEC form generation for the permit submittal. We propose to provide the online modeling analysis for a fixed fee of \$5,330.~~
4. AV Design: This service was an added service in our original proposal and some of the work was completed already. Some time will be needed to revisit the design and finish to 100% CDs. This requires a projector screen and/or large format LCD screen with speakers and microphone system and remote multi-media connections for teleconferencing. This would require additional coordination and design with Technology personnel. We propose to provide the above scope for a **fixed fee of \$2,500.**
5. CCTV and Card Key Access Control Design: This service was an added service in our original proposal and some of the work was completed already. Some time will be needed to revisit the design and finish to 100% CDs. BCE can finish the planning with the Owner, coordination with the team on the locations and accommodations needed for these systems, and the design. We propose to provide the above scope for a **fixed fee of \$2,500.**
6. Cost Estimate Support: **EXCLUDED** – It is assumed any cost estimating will be done by others and is not included.
7. Frontage Improvements (Offsite electrical work, Utility relocation and Street Lighting): this effort is separate from the Building Design work and entails extensive coordination with multiple utility providers and the jurisdiction. In addition, we will provide plans, specifications and calculations as required for the contractor to bid the work. If frontage work is required, we will defer discussion of additional effort at a later time.

## Exclusions for 100% CD level effort:

- Bidding Services
- Construction Administration
- Commissioning support
- Sewage lift station.

- LEED documentation and submittal
- Off-Site Power Design
- Emergency Generator Design
- Studies for indoor air quality
- Alternate Bid Designs
- Energy Modeling
- Life Cycle Cost Analysis
- Insurance Limits Exceeding \$2,000,000 per claim and \$4,000,000 aggregate
- Acoustic Analysis
- Coordinating with a GCCM/MCCM process
- Enhanced building envelope modeling
- Fire pumps
- Smoke Evacuation Systems
- Data Network electronic equipment (switches, routers, WAPs)
- Telephone system equipment
- Evacuation assistance systems
- Seismic calculations for mechanical and electrical components
- All work associated with the research, application, and submittals for grant money
- Clash detection beyond standard design coordination is excluded.

This proposal is based on a normal design period which continues through to completion without substantial or repeated delays. In situations where these delays occur, BCE Engineers reserves the right to request additional compensation.

Again, thank you for the opportunity to work on this project with you, and if you have any questions please do not hesitate to call.

Sincerely,

**BCE ENGINEERS, LLC**

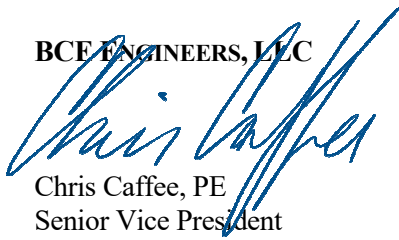

Chris Caffee, PE  
Senior Vice President



# Proposal

---

CLIENT	Mark Hurley	DATE	April 10 <sup>th</sup> , 2025
CLIENT CONTACT	TCF Architecture, PLLC	PROJECT	City of Sumner Heritage Parks Event Center

---

Dear Mark,

Please see below our proposal for providing cost consulting services for the City of Sumner Heritage Parks Event Center Project.

Provide cost consulting services at the following design stages:

- Construction Documents Update

## 2.1 Cost Estimate

The cost estimate will be based on the measurement of quantities from drawings and provided information and priced in accordance with these drawings and descriptions of the work. It is our understanding the design team will be including all sitework related estimates for both Civil and Landscape scopes of work.

## 2.2 Format

The estimates will be presented in elemental format or that determined by the project team.

## 2.3 Exclusions

Any design work or estimating beyond the above stated services and scope and beyond the site.

## 2.4 Meetings / Follow Up / Estimate Review

We have assumed for this fee proposal for (1) hour of meetings, conference calls and follow-up.

## 2.5 Project Staffing Assignment

- Andy Cluness (25+ Years' Experience) – Senior Estimator / PIC
- Melia Blankenship (15+ Years' Experience) – Senior Estimator
- John Perry (30+ Years' Experience) – Senior Estimator
- Neil Watson (30+ Years' Experience) – Senior MEP Estimator

## 3a. Basic Services Fees

Our Not To Exceed Fee To Be Billed on an Hourly Basis for cost estimating services are **\$9,030** for the following services:

### Construction Documents Estimating = \$9,030 (42 Hours x \$215/Hr.)

- Report Prep / Set Up / Internal Meetings: 1 Hour
- Architectural and Structural Estimating: 24 Hours
- Mechanical Estimating: 8 Hours

- Electrical Estimating: 7 Hours
- Civil and Landscape Estimating: By JETT
- Meetings With Design Team and or Owner / Follow-Up: 1 Hour
- QA/QC: 1 Hour

**4. Expenses**

Direct reimbursable expenditures if appropriate will be charged in accordance with the prime agreement or Our Hourly rates for miscellaneous additional services will be billed as reimbursable at \$215/Hr. Flights and Accommodations will be billed at Cost + 10%. *We are not anticipating expenses for this project.*

**5. Payment**

We will invoice on completion of each phase for payment net thirty (30) days. This proposal remains open for acceptance for a period of three months after which time the writer should be consulted for verification of scope and fees.

**6. Project Schedule**

Based on our understanding of the current schedule that if successful in our proposal we would receive the documents on the following dates for the formal submittals of our service:

**Documents to RC Cost Group**

Per Schedule

**Complete Cost Plan**

Per Schedule

*We look forward to the opportunity of working with you on this important project and if you have any questions regarding this proposal or the fee structure, please give us a call. Thank you.*

Yours Truly,



**Andrew Cluness, Managing Partner**

RC Cost Group, INC.

**Confirmation of Agreement:**

This letter correctly sets out the scope and fees for services to be provided by RC Cost Group, Inc. for this project.

\_\_\_\_\_  
SIGNATURE OF AUTHORIZED OFFICER

\_\_\_\_\_  
TITLE OF AUTHORIZED OFFICER

\_\_\_\_\_  
DATE

**EXHIBIT ‘E’**

**Subconsultant scope of work Task 2.2 & 2.3 (HPEB Specifications & Advanced Renderings)**

	PROJECT TASKS	TCF Architecture Architecture / Planning			TOTALS
		Principal In Charge	Design Director	Arch/Design	
<b>Model Clean up/Material Placement</b>					
	<b>Floor 1</b>	0.5	1	12	<b>\$2,065</b>
	<b>Floor 2</b>	0.5	1	6	<b>\$1,225</b>
	<b>Floor 3</b>	0.5	1	12	<b>\$2,065</b>
	ESTIMATED HOURS OR FEES	2	3	30	
	HOURLY RATE	\$350.00	\$210.00	\$140.00	
	ESTIMATED FEES	\$525	\$630	\$4,200	
	<b>SUBTOTAL</b>	<b>\$5,355</b>			<b>\$5,355</b>
<b>Animation</b>					
	<b>Floor 1</b>	0.5	1	16	<b>\$2,625</b>
	<b>Floor 2</b>	0.5	1	10	<b>\$1,785</b>
	<b>Floor 3</b>	0.5	1	16	<b>\$2,625</b>
	<b>Site</b>	0.5	2	6	<b>\$1,435</b>
	<b>Coordination</b>	1	4	4	<b>\$1,750</b>
	<b>City review adjustments</b>	1	2	14	<b>\$2,730</b>
	ESTIMATED HOURS OR FEES	4	11	66	
	HOURLY RATE	\$350.00	\$210.00	\$140.00	
	ESTIMATED FEES	\$1,400	\$2,310	\$9,240	
	<b>SUBTOTAL</b>	<b>\$12,950</b>			<b>\$12,950</b>
<b>Specifications</b>					
	<b>100% Specs</b>	10	60	4	<b>\$16,660</b>
	ESTIMATED HOURS OR FEES	10	60	4	
	HOURLY RATE	\$350.00	\$210.00	\$140.00	
	ESTIMATED FEES	\$3,500	\$12,600	\$560	
	<b>SUBTOTAL</b>	<b>\$16,660</b>			<b>\$16,660</b>
		<b>\$34,965</b>			
<b>TOTAL ESTIMATED HOURLY FEE BUDGETS and REIMBURSABLE EXPENSES</b>					<b>\$34,965</b>

## **EXHIBIT 'F'**

### **Sub-consultant scope of work Task 1 (Site team proposals)**

## SCOPE OF WORK

This Scope of Work submitted to JETT Landscape Architecture & Design includes services to complete the civil engineering design and construction documents for the Reuben A. Knoblauch Heritage Park Master Plan & Alley Activation project in Sumner, WA. Phase 3 Park Site and Phase 4 Building.

### TASKS AND DELIVERABLES

#### 2.0 HERITAGE PARK

##### A. Project Management

JMJ TEAM will provide internal team coordination, documentation, and QA/QC of civil engineering documents for the park and the building

##### B. Building Permit Production

JMJ TEAM will provide civil engineering design for the proposed building and park including updating and preparing plans in coordination with the City and consultant team. Tasks include:

- Team Meetings (6)
- Client Meetings (2)
- Utility Report
  - Sanitary Sewer Grease Interceptor Sizing
- Stormwater Report and Design
  - Water Quality
  - Flow Control – Infiltration/Retention
  - Modeling
  - Conveyance Calculations
  - Construction Stormwater
- Plan Design and Production
  - Existing Site Plan
  - Proposed Site Plan
  - Grading Plan
  - Building Layout Plan
  - Water System Plan
  - Sanitary Sewer Plan
  - Stormwater Plan
  - Frontage Plan (Maple)
  - Hardscape Plan
  - Details
  - Private Utility Plan

### **C. Specifications Update**

JMJ TEAM will provide civil engineering services for the proposed building and park including updating and preparing specifications in coordination with the City and consultant team. Tasks include:

- Review current civil specifications and identify required updates to CSI format
- Prepare building civil specifications in CSI format

### **D. Building Permit Issuance**

JMJ TEAM will provide civil engineering services for the proposed building and park for building permit submittals, revisions, and responses in coordination with the City and consultant team. Tasks include:

- Producing conformed permit set (civil)
- Producing submittals and resubmittals packages (civil)
- Producing comment responses (civil)
- Meeting as needed

### **E. Revisions & V.E.**

JMJ TEAM will provide civil engineering services for the proposed building and park for value engineering in coordination with the City and consultant team. Tasks include:

- Develop V.E. civil options
- Implement V.E. changes that are approved
- Internal QA of V.E. changes

### **F. IFC Issuance**

JMJ TEAM will provide civil engineering services for the proposed building and park for IFC Issuance in coordination with the City and consultant team. Tasks include:

- IFC drawing packaging (civil)
- IFC specification packaging (civil)

**G. Contractor / Owner/ Team Meetings**

JMJ TEAM will provide civil engineering services for the proposed building and park in coordination with the City and consultant team. Tasks include:

- Project startup meetings (3)
- Team meetings (13)

**Deliverables:**

- Building Permit Draft Set – 100% CD Update set (Jett Internal team)
- Building Permit
- Project specifications (JETT, BCE), Front End (Civil)
- IFC Set & Bid Plans

**Schedule:**

- 6 Months starting April 2026

**ASSUMPTIONS**

- Electronic copies of all deliverables will be provided for reproduction by others.
- Jurisdiction permit and application fees are not included.
- Standard expenses such as mileage and basic copies are included
- Bidding and Construction Administration Services are not included

**PROJECT FEES**

See attached budget spreadsheet for budget and task breakdowns. A summary of the Phase totals is provided below. The fee is to be billed on an hourly not to exceed basis.

JMJ #	1607-001-02	STAFF								
	Heritage Park -Phase 3/4 Final Design		Senior Engineer	Senior Planner	Designer/Engineer	Drafter	Project Facilitator			
WO #		BILL RATES	\$270.00	\$200.00	\$170.00	\$130.00	\$160.00		TOTAL HOURS	TOTAL COST
<b>1.0 Heritage Park Event Building and Park</b>										
<b>1.1 Phase 3/4 Bid Documents (6 Months)</b>										
	Project Management		6	2			8		16	\$3,300
	Meetings (16)		16		16		8		40	\$8,320
	Utility Design Report		4		4				8	\$1,760
	Stormwater Report/Modeling		4		16				20	\$3,800
	Civil Plans		24		120	120			264	\$42,480
	Existing Site Plan									
	Building Site Plan									
	Building Control Plan									
	TESC Plan									
	Hardscape Plans and Details									
	Demo Plan									
	Subgrade Prep Plans									
	Site Plans									
	Water/Fire Plans and Details									
	Sanitary Sewer Plans and Details									
	Stormwater Plans and Details									
	Grading Plans									
	Frontage Parking/Loading Plans									
	JUT Plans									
	Details									
	Cost Estimate		6		12				18	\$3,660
	Specifications		8		24		22		54	\$9,760
	Revisions & V.E		8		24	32	4		68	\$11,040
	IFC Issuance		8		24				32	\$6,240
	Permit Submittals			6	3	1	40		50	\$8,240
	<i>Subtotal</i>								404	
<b>Project Total</b>			<b>84</b>	<b>8</b>	<b>243</b>	<b>153</b>	<b>82</b>		<b>404</b>	<b>\$98,600</b>

## **TERMS AND CONDITIONS**

### **SECTION 1 - BASIC SERVICES OF ENGINEER**

#### 1.1 General.

1.1.1. The Basic Services to be performed by JMJ TEAM, hereinafter referred to as ENGINEER, are defined in the attached proposal letter agreement, hereinafter referred to as Letter of Agreement. When Letter of Agreement is signed by both parties, with the second party hereinafter referred to as CLIENT, the Letter of Agreement invokes the Standard Agreement and Terms And Conditions contained herein.

1.1.2. The part of the Project for which ENGINEER is to provide services described in the attached Letter of Agreement and in this document is hereinafter referred to as This Part of the Project.

1.1.3. ENGINEER will collaborate with CLIENT and CLIENT's consultants to the extent required to provide a coordinated design for the overall Project. All communications with the CLIENT's consultants or other Project participants will be through or with the knowledge of the CLIENT. Except as set forth herein, ENGINEER will not have any duties or responsibilities for any other part of the Project. ENGINEER will perform services in character sequence and timing so that it will be coordinated with that of CLIENT and other consultants for the Project. ENGINEER agrees to a mutual exchange of Drawings and Specifications for the Project with CLIENT and other consultants.

1.1.4. If you have chosen not to have the ENGINEER and the consultants of the ENGINEER provide construction administration services on the project, then those services shall be excluded from our contract. The CLIENT shall then assume the liability to ensure that the project is constructed in accordance with the design of the ENGINEER and the CLIENT will hold the ENGINEER harmless from any claim due to the contractor not building per plans and specifications.

### **SECTION 2 - ADDITIONAL SERVICES**

#### 2.1 General.

If authorized in writing by the CLIENT, ENGINEER shall furnish or obtain from others Additional Services of the following types which are not considered normal or customary Basic Services except to the extent provided in the attached Letter of Agreement; these will be paid for by CLIENT as indicated in Section 5.

2.1.1. Services to make measured drawings of or to investigate existing conditions or facilities, or to verify the accuracy of drawings or other information furnished by CLIENT.

2.1.2. Services resulting from significant changes in extent of This Part of the Project or its design including, but not limited to, changes in size, complexity, CLIENT's schedule, or character of construction; and revising previously accepted studies, reports, design documents, or Contract Documents when such revisions are due to causes beyond ENGINEER's control.

2.1.3. Additional services in connection with This Part of the Project; including services normally furnished by CLIENT, and services not otherwise provided for in this or the attached Letter of Agreement such as: services of special consultants, value engineering, detailed cost estimates, or Bid Phase or Construction Phase services.

### **SECTION 3 - CLIENT'S RESPONSIBILITIES**

CLIENT shall:

3.1. Provide all criteria and full information as to CLIENT's requirements for the Project including design objectives and constraints, space, capacity and performance requirements, flexibility and expandability, and any budgetary limitations. Furnish copies of all design and construction standards which CLIENT will require to be included in the Drawings and Specifications.

3.2. Assist ENGINEER by placing at his disposal all available information pertinent to the Project including previous reports and any other data relative to design or construction of the Project.

3.3. Arrange for access to and make all provisions for ENGINEER to enter upon public and private property as required for ENGINEER to perform his services.

3.4. Furnish, or direct ENGINEER in writing to provide, necessary Additional Services as stipulated in Section 2 of this Agreement or other services as required.

3.5. Bear all costs incident to compliance with the requirements of this Section 3.

### **SECTION 4 - PERIOD OF SERVICE**

4.1. The provisions of this Section 4 and the various rates of compensation for ENGINEER's services provided for elsewhere in this Agreement have been agreed to in anticipation of the orderly and continuous progress of the Project through completion of the Design Phase (unless otherwise stated in attached proposal letter). ENGINEER's obligation to render services hereunder will extend for a period that may reasonably be required for the design (unless otherwise stated in attached proposal letter) of This Part of the Project; including extra work and required extensions thereto.

4.2. If ENGINEER's services for design (or phases as stated in attached proposal letter) of This Part of the Project are delayed or suspended (in whole or in part) by CLIENT for more than two weeks for reasons beyond ENGINEER's control then ENGINEER shall, on written demand to CLIENT (but without termination of this Agreement) be paid as provided in paragraph 5.3.1. If such delay or suspension extends for more than three months (for reasons beyond ENGINEER's control) or if ENGINEER, for any reason, is required to render services more than three months after initial date of letter of agreement, the various rates of compensation shall be subject to renegotiation.

## **SECTION 5 - PAYMENTS TO ENGINEER**

5.1.1. For Basic Services. CLIENT shall pay ENGINEER for Basic Services described in the Letter of Agreement rendered under Section 1 the Lump Sum or Time and Materials Fee as described in the Letter of Agreement.

5.1.2. For Additional Services. CLIENT shall pay ENGINEER for Additional Services rendered under Section 2 as follows:

5.1.2.1. General. For Additional Services rendered, under paragraphs 2.1.1 through 2.1.3, the fee shall be that which is agreed upon on an Authorization for Additional Services form. This Authorization for Additional Services form shall be issued at the time of CLIENT's request and shall include revised scope of work. The Authorization for Additional Services form shall be signed by the CLIENT and this will act as notice to proceed with Additional Services.

5.1.3. Reimbursable Expenses. In addition to payments provided for in paragraphs 5.1.1 and 5.1.2, CLIENT shall pay ENGINEER the actual costs (times a factor of 1.08) of all Reimbursable Expenses incurred in connection with all Basic and Additional Services if defined in the attached Letter of Agreement.

5.1.4. The terms "Reimbursable Expenses" will have the meanings assigned in paragraph 5.4.

### **5.2. Times of Payments**

5.2.1. ENGINEER shall submit monthly or semi-monthly invoices for Basic and Additional Services rendered and for Reimbursable Expenses incurred. The invoices will be based upon ENGINEER's estimate of the proportion of the total services actually completed at the time of billing. Payment terms are net 30 days. CLIENT shall make prompt payments in response to ENGINEER's statements.

### **5.3. Other Provisions Concerning Payments.**

5.3.1. In the event of termination by CLIENT under paragraph 7.1 of the Basic Services; ENGINEER will be paid for services rendered up to that time (on the basis of The Letter of Agreement Rate Schedule, if included. Otherwise, Direct Labor Costs times a factor of 3.2) for services rendered to date of termination by principal and employees assigned to This Part of the Project. In the event of any such termination, ENGINEER will be paid for all unpaid Additional Services and unpaid Reimbursable Expenses, plus all termination expenses. Termination Expenses mean Reimbursable Expenses directly attributable to termination, which shall include an amount computed as a percentage of total compensation for Basic Services earned by ENGINEER to the date of termination, as follows:

20% if termination occurs after commencement of the Design Phase.

#### 5.4. Definitions.

5.4.1. The Direct Labor Costs used as a basis for payment means salaries and wages (basic and incentive) paid to all personnel engaged directly on the Projects, including but not limited to; engineers, designers, drafters, estimators, administration, and clerical.

5.4.2. Reimbursable Expenses means the actual expenses incurred (directly or indirectly) in connection with the Project for: obtaining bids or proposals from Contractor(s); postage, toll telephone calls and telegrams; reproduction of reports, Drawings, Specifications, and similar Project related items in addition to those required under Section 1; project related travel and lodging costs; and, if authorized in advance by CLIENT, overtime work requiring higher than regular rates.

### **SECTION 6 - OPINIONS OF COST**

#### 6.1. Opinions of Cost.

6.1.1. Since Engineer has no control over the cost of labor, material, equipment, or services furnished by others; or over the Contractor(s) methods of determining prices; or over competitive bidding or market conditions; then his opinions of probable Construction cost for This Part of the Project provided for herein are to be made on the basis of his experience and qualifications; and represent his best judgment as an experienced and qualified Professional Engineer (familiar with the construction industry). ENGINEER cannot and does not guarantee that proposals, bids, or actual Construction Cost for This Part of the Project will not vary from opinions of probable cost prepared by him. If prior to the Bidding or Negotiating Phase CLIENT wishes greater assurance as to Construction Cost for This Part of the Project he shall employ an independent cost estimator as provided in paragraph 2.1.3.

### **SECTION 7 - GENERAL CONSIDERATIONS**

#### 7.1. Termination.

7.1.1. The obligation to provide further services under this Agreement may be terminated by either party upon seven days written notice.

#### 7.2. Reuse of Documents.

7.2.1. All documents including Drawings and Specifications prepared by ENGINEER pursuant to this Agreement are instruments of service in respect of the Project. They are not intended or represented to be suitable for reuse by CLIENT or others on extensions of the Project or on any other project. Any reuse, without written verification or adaptation by ENGINEER for the specific purpose intended, will be at CLIENT's sole risk and without liability or legal exposure to ENGINEER; and CLIENT shall indemnify and hold harmless ENGINEER from all claims, damages, losses, and expenses (including attorney's fees) arising out of or resulting therefrom. Any such verification or adaptation will entitle ENGINEER to further compensation at rates to be agreed upon by CLIENT and ENGINEER.

### 7.3. Records.

7.3.1. Records of ENGINEER's Direct Labor Costs, Payroll Costs, and Reimbursable Expenses (pertaining to This Part of the Project) will be kept on a generally recognized accounting basis and made available to CLIENT on request.

7.3.2. ENGINEER shall maintain all design calculations on file in legible form. A copy of these shall be available to CLIENT at ENGINEER's expense; and the originals shall not be disposed of by ENGINEER until after sixty days prior written notice to CLIENT or 60 months after project completion without notice.

7.3.3. ENGINEER's records and design calculations will be available for examination and audit as required in writing by CLIENT.

### 7.4. Insurance.

7.4.1. CLIENT and ENGINEER shall each procure and maintain insurance (other than life insurance) for protection from claims under worker's compensation acts, claims for damages because of bodily injury (including personal injury), sickness or disease or death of any and all employees or of any person other than such employees, and from claims or damages because of injury to or destruction of property including loss of use resulting therefrom.

7.4.2. Also CLIENT and ENGINEER shall each procure and maintain professional liability insurance for protection from claims arising out of performance of professional services caused by any negligent error, omission, or act for which the insured is legally liable. Such professional liability insurance will provide for coverage in such amounts, with such deductible provisions, and for such periods of time as appropriate for the size of the project; and certificates indicating that such insurance is in effect will be exchanged by them.

7.4.3. CLIENT will also cause other professional consultants retained by CLIENT for the Project to procure and maintain comparable professional liability insurance coverage.

7.4.4. CLIENT agrees to limit the ENGINEER's liability to the CLIENT and to all construction contractors and subcontractors on the project, due to the ENGINEER's negligent acts, errors or omissions, or any claim of any nature whatsoever arising out of or relating to the performance of professional services under this agreement, such that the total aggregate liability of the ENGINEER to all those named shall not exceed \$50,000 or the ENGINEER's total fee for services rendered on this project, whichever is greater.

### 7.5. Controlling Law.

7.5.1. This Agreement is to be governed by the law of the State of Washington.

### 7.6. Successors and Assigns.

7.6.1. CLIENT and ENGINEER each binds himself and his partners, successors, executors, administrators, assigns and legal representatives to the other party to this Agreement and to the partners, successors,

executors, administrators, assigns and legal representatives of such other party, in respect to all covenants, agreements and obligations of this Agreement.

7.6.2. Neither CLIENT nor ENGINEER shall assign, sublet, nor transfer any rights under or interest in (including, but without limitation, moneys that may become due or moneys that are due) this Agreement without the written consent of the other, except as stated in paragraph 7.4.1. and except to the extent that the effect of this limitation may be restricted by law. Unless specifically stated to the contrary in any written consent to an assignment, no assignment will release or discharge the assignor from any duty or responsibility under this Agreement. Nothing contained in this paragraph shall prevent ENGINEER from employing such independent consultants, associates, and subcontractors as he may deem appropriate to assist him in the performance of services hereunder.

7.6.3. Nothing herein shall be construed to give any rights or benefits hereunder to anyone other than CLIENT and ENGINEER.

**SIGNATURE**

By signing this document, I agree to the Scope of Work and Project Budget contained herein.

\_\_\_\_\_  
Project Owner

\_\_\_\_\_  
Date

**JMJ TEAM**

\_\_\_\_\_  
Justin Jones, PE Vice President

\_\_\_\_\_  
Date





December 5, 2025

Jett Landscape Architecture + Design  
93445 California Ave SW,  
Seattle, WA 98116

Attn: Todd Bronk

**RE: City of Sumner Heritage Park Phases 3 Bid and IFC Documentation– Electrical Design Fee**

Dear Todd,

I appreciate another opportunity to support you and your team by providing engineering services to support completing the electrical design of the Sumner Heritage Park Phases 3 and 4. Based on the previous discussions and information provided, I have listed the breakdown of our anticipated effort below to support the project:

The scope of work as we understand it is as follows:

- Provide detailed plans to transition power, AV, lighting circuits and lighting controls for the completed phase 2 project to the new Heritage Building.
- Meet with the City of Sumner IT to coordinate infrastructure.
- Verify and complete the power and circuiting design.
- Provide details and high level coordination of all remote drivers required to support all site lighting.
- Outdoor lighting circuiting and controls to be designed under the 2021 Washington State Energy Code. BCE will be coordinating circuits and controls requirements with the lighting designer. NREC lighting forms for the plan review submittal to be provided by the lighting designer.
- Provide power infrastructure to support the event lawn and stage power requirements.
- Coordinate and verify all power hook-ups to the four designated food truck parking areas.
- Coordinate and verify site conduit and data (infrastructure only) (conduit and cabling back to building communications room)) to support any City WAP (Wireless Access Point).
- Coordinate and verify site conduit and data (infrastructure only) (conduit and cabling back to building communications room) to support the A/V and communications needs at the stage and event lawn.
- Coordinate and verify EV Charging (per WAC requirements): Level 2 Electric Vehicle charging will be required by the Washington State Administrative Code (WAC) in March of 2024. Coordination with the Owner on the amount, location, and style of charging, to arrange electric gear sizing, and to help plan the site layout.
- Provide basic electrical cost analysis.
- Provide Specifications in SCI format.
- Project Deliverables:
  - 100% CD Draft Set
  - 100% CD Set (Permit Set)

- IFC Set

We propose a **fixed fee of \$18,000** to cover this service.

The basic services agreement covers formal submittal packages for 100% Permit set and IFC set. Informal check sets for coordination purposes are included under the basic services. Any additional formal submittals will be considered outside the basic scope of work and additional compensation will be negotiated at that time. Submittals for all site electrical related drawings will be generated in AutoCad.

Additional Extra Services and Options:

1. Stage and Event Lawn AV Design: The basic site infrastructure only scope to support the A/V is included with the basic service. If a complete site PA and A/V system design is required, this would require additional coordination and design with Technology personnel. We propose to provide the above scope for a **fixed fee of \$6,500**.
2. CCTV: The basic site infrastructure only scope to support the site CCTV coverage is included with the basic service. If a complete installed CCTV system design is required, this would require additional coordination and design with Technology personnel. We propose to provide the above scope for a **fixed fee of \$4,500**.
3. PSE Follow-up and Coordination of Service Transformer: Lead the coordination with PSE to coordinate and finalize required offsite 3-phase power underground extension to support the Heritage Park building service transformer. This additional scope will also include further coordination to apply for variance for an underground transformer. We propose to provide the above scope for a **fixed fee of \$5,500**.

Exclusions:

- Phase 4 Package. It is assumed that this design phase will combine the previous phase 3 and 4 design into one design package.
- Any design outside of the above-mentioned scope of work
- Commissioning support
- LEED documentation and submittal
- Off-Site Power Design
- Emergency Generator Design
- Insurance Limits Exceeding \$2,000,000 per claim and \$4,000,000 aggregate
- Data Network electronic equipment (switches, routers, WAPs)
- All work associated with the research, application, and submittals for grant money
- Construction Administration is not part of the above design scope.
- Value Engineering

As the scope of work is not defined for these items, we would defer any negotiations until further information is known.

This proposal is based on the design schedule per Exhibit B which continues through to completion without substantial or repeated delays. In situations where these delays occur, BCE Engineers reserves the right to request additional compensation.

Again, thank you for the opportunity to work on this project with you, and if you have any questions please do not hesitate to call.

Sincerely,

Thank you again for this opportunity to provide our services for this work. If you have any questions or need further information, please feel free to give me a call.

Sincerely,

**GFT Infrastructure, Inc.**

A handwritten signature in black ink, appearing to read "Henry Santos". The signature is stylized with a large, looped "H" and "S".

Henry Santos

Associate Principal/Vice President



**Swenson Say Fagét**

STRUCTURAL ENGINEERING

2124 Third Avenue, Suite 100  
Seattle, WA 98121  
☎ 206.443.6212

934 Broadway, Suite 100  
Tacoma, WA 98402  
☎ 253.284.9470

⊕ [ssfengineers.com](http://ssfengineers.com)

October 20th, 2025

Todd Bronk  
JETT Landscape Architecture  
3445 California Avenue SW  
Seattle, WA 98116

*RE:* Proposal for Structural Engineering Services, City of Sumner, Heritage Park, – Phase 3 Area

Thank you for inviting our proposal for structural engineering services for the City of Sumner Heritage Park project. SSF Engineers has extensive experience with public work projects of this type. This document is to confirm our understanding of the scope of services and compensation for this project. This proposal is based on our previous drawings as well as continued correspondence with your office.

**Project Understanding and Scope of Work**

It is our understanding that JETT Landscape Architects has been retained for continued design of Heritage Park for the City of Sumner. Our scope will include the structural design and documentation for several items within Heritage Park phase 3 area shown in the RFP exhibit documents. These include the support foundations for light poles, flag poles, play area equipment, possible stage redesign (previous engineered), stage retaining wall, review of other miscellaneous architectural site features including site walls. For this proposal we will assume that the soils report from Phase 2 applies to this area as well. Construction administration services are excluded from this proposal.

**Project Management Phases and Associated Fees**

We propose a full scope of services that include drafted drawings, details, structural specifications, and structural calculations. Our fees for the services noted above are as follows:

Building Permit Production (100% CD level drawings)	\$9,400
Permit Comments and response process	\$5,600
Revisions and Value Engineering	\$3,000
Issue for Construction	\$2,600
Team Meetings	<u>\$3,400</u>
<b>Total</b>	<b>\$24,000</b>

**Deliverables**

Deliverables include building permit package, structural specifications (included in our general structural notes), construction drawings, and bid drawings.

**Schedule**

It is our understanding that the schedule for developing documents will start at the end of April and extend through summer 2026.

**Schedule of Conditions**

This proposal is based on the above project description, as well as the attached Schedule of Conditions that is part of this agreement. Our hourly rates and billing particulars are included in our Schedule of Conditions.

We intend to furnish our services in accordance with the attached Memorandum of Engagement for Professional Services which defines completely the agreement between us. You should understand that no other conditions, express or implied, will apply to Swenson Say Faget’s performance of its services. If you accept these conditions, please return to us a signed copy of this proposal.

If we have not received the countersigned proposal before we begin to perform our services or you do not otherwise object to our Memorandum in writing prior to our beginning work, we will proceed according to the Memorandum of Engagement and assume that it is acceptable to you.

Thank you again for inviting our proposal for continued structural engineering services on the City of Sumner Heritage Park design. We look forward to being part of the design team.

Sincerely,

SWENSON SAY FAGÉT  
A Structural Engineering Corporation

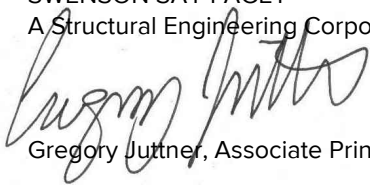

Gregory Juttner, Associate Principal, P.E., S.E.

\_\_\_\_\_  
JETT Landscape Architects



**SEATTLE  
TACOMA**

2124 Third Avenue, Suite 100, Seattle, WA 98121  
934 Broadway, Suite 100, Tacoma, WA 98402

○ 206.443.6212  
○ 253.284.9470

⊕ [ssfengineers.com](http://ssfengineers.com)

## System Proposal

### Scope of Work

This proposal provides assistance with design review of security systems and submittals for Heritage Park and Heritage Park Event Building. Systems include video camera, access control, and intrusion. SSNW design team will provide details, feedback, and notes regarding security design to assist with bid package.

Hourly rates for added design requests are \$109/hour.

- Scope broken down per task below
- Includes project manager for remote meetings
- Includes review time for feedback and modifications
- Includes site labor if needed (provided by sales team)

This quote is based on the following assumptions:

- Excludes specifications and/or 3D renderings - To be provided by electrical engineer
- Excludes permit submission, review, and/or costs - To be provided by electrical engineer

NOTE: SEE THE INCLUSIONS/EXCLUSIONS TABLE IN THIS PROPOSAL FOR ADDITIONAL INCLUSIONS AND EXCLUSIONS, ALONG WITH THE PRODUCT-SPECIFIC ONES LISTED ABOVE

### Task 1.0 - Design and submittals - Heritage Park

<u>Qty</u>	<u>Description</u>
1	Labor for design team to review and provide notes/feedback/details
1	Labor for Project Management

<b>Task 1.0</b>	<b>\$1,440</b>
-----------------	----------------

*+ sales tax*

### Task 2.0 - Design and submittals - Heritage Park Event Building

<u>Qty</u>	<u>Description</u>
1	Labor for design team to review and provide notes/feedback/details
1	Labor for Project Management

<b>Task 2.0</b>	<b>\$3,810</b>
-----------------	----------------

*+ sales tax*

<b>TOTAL</b>	<b>\$5,250</b>
--------------	----------------

*+ sales tax*

THESE ITEMS ARE **EXCLUDED** UNLESS MARKED YES:

Included in Scope:	Yes:	Included in Scope:	Yes:	Included in Scope:	Yes:
Shop Drawings		Panel		Electrical Permit	
As-Built Drawings		Panel Install		WA Prevailing Wages	
REVIT LOD Design		Panel Program /Test		Davis Bacon Wages	
Data Submittals		Fire Stopping		P & P Bond	
Wire Supply		Door Lock Hardware		Programming	
Wire Installation		Door Lock Hardware Installation		System Testing	
Conduit & Installation		120v ac Power Material & Install		Training - On-site	
Coring		Provide Lift(s)		Training - Remote 1 hrs.	
Devices		POE Switches		Training - Remote 4 hrs.	
Devices Install		Magnetic Door Holders			
Devices Program/ Test					

TERMS AND CONDITIONS:

- Proposal is valid for 10 days from the date on this proposal, however, SSNW may adjust prices in this proposal should costs increase due to new or higher tariffs, duties, or government levies imposed after the acceptance date. Price adjustments must be proportional to SSNW's increased costs and will be communicated to the Customer in writing with supporting documents.
- If quote is over \$5000, an authorized purchase order and/or contract are required to commence work
- A system with monitoring or cloud hosting will require a contract to activate
- Additional work requested beyond the scope of this proposal will be billed at a time & material rate
- Customer to provide robust & reliable Wifi connection if needed; parts needed to connect a cellular communicator with a weak cellular signal will be billed as an additional cost
- Proposal is based on plans noted above. If plans are found to be incorrect or incomplete during the design process, we will bill for the additional time
- Existing wiring or equipment integrated into this scope of work is assumed to be in working order and supported by the manufacturer, any work and parts needed to upgrade or fix will be billed at a time and material rate
- All work to be performed during SSNW's business hours Monday - Friday 8:00 - 4:30 excluding holidays
- All parts and labor are warranted for one year
- Work will be billed each month in increments proportionate to progress toward completion of the project
- Balance to be billed at the completion of installation, payments are due at net 30 days from invoice date
- Pay Portal Fees are not included and will be billed to customer with a 10% markup

Presented by: \_\_\_\_\_  
Tom McKellar - 206.513.3405

Acceptance: \_\_\_\_\_  
(please sign here)

\_\_\_\_\_ Date

# JETT Landscape Architecture + Design

## City of Sumner Heritage Park Building Audiovisual, (AV) System Design Phase 3 & 4

---

### AUDIOVISUAL SOLUTION PROPOSAL

Avidex Project 100260089  
Version 3



Submitted by

Dave Crace  
425-274-7916

[dave.crace@avidex.com](mailto:dave.crace@avidex.com)

---



8509 154<sup>th</sup> Avenue NE Suite 100 | Redmond, WA 98052 | 425.643.0330

## TABLE OF CONTENTS

STATEMENT OF WORK .....	3
INTRODUCTION .....	3
SCOPE OF WORK .....	3
KEY PERSONNEL.....	13
PRICE AND PAYMENT SCHEDULE .....	14
AUTHORIZATION TO PROCEED – DESIGN SERVICES.....	15

© Avidex Industries, LLC. Copyright 2019. This proposal is the property of Avidex. Avidex and the Avidex logo are the property of Avidex Industries, LLC. This document contains proprietary data and concepts that are the property of Avidex Industries, LLC. Information, details and/or specific data may not be reproduced or duplicated.

---

## STATEMENT OF WORK

---

Avidex is pleased with the opportunity to respond to the City of Sumner request for support for the new Sumner Heritage Park Building audiovisual system. The City's goal is to have the AV system perform reliably and new AV technology to include redundancy in the design where necessary to avoid issues and failures in reliability and performance. The City of Sumner facilities within the scope of the project consist of the following:

1. Heritage Park Grounds and Hops Alley (Project Phase 3)
2. Heritage Park Building (Project Phase 4)

## INTRODUCTION

---

Avidex has the experience, certifications and capability to support the City of Sumner's request to provide audiovisual, (AV) consulting to evaluate and recommend solutions for AV systems within the Heritage Park Grounds and Building.

This project involves an AV systems design for the building located at 914 Kincaid Avenue Sumner, WA. 98390.

## SCOPE OF WORK

---

Avidex has reviewed the shared document package and the AV system design will be developed around the following Scope of Work, specifically identified in the "Heritage Park & Event Building - AV Scope RFP" document. This document is the starting point for Avidex involvement. It is anticipated of course that this scope definition will be elaborated, refined and revised during the process of engagement with the project.

### First Floor

#### Flexible Event Space (100) – Public Use

- Presentation capable space
- Speech reinforcement
- Ability to support third party event A/V vendors

#### Conference Room (103) – Public Use

- Video conferencing capable
- Display system
- Cable TV capability

#### Anchor Tenant Space (101, 101A)

- Cable TV capability
- Infrastructure only for future tenant A/V

## A/V Equipment Room (104)

- Centralized A/V headend and distribution location for Park

## Second Floor

### Large Conference Room (200)

- Video conferencing capable
- Display system
- Cable TV capability

### Small Conference Room (214)

- Video conferencing capable
- Display system
- Cable TV capability

### Staff Breakroom (215)

- Display system
- Cable TV capability

## Third Floor

### City Council Chambers (302)

- Council meeting audio system
- Video conferencing capability
- Integration with external broadcast provider
- Layout of the 3<sup>rd</sup> floor is changing. Council Chamber location will change.

### Council Chambers A/V Control Room (302A)

- Space for broadcast control and switching equipment
- Single operator position

### Conference Room (301) – Public Use

- Video conferencing capable
- Display system

## Park / Exterior

### Park Audio

- Distributed background audio to existing and future light poles
- Infrastructure to support temporary third-party event systems
- Need to understand the conduit sizes to run to poles, if poles need a separate conduit to run wire with 120V / 240V wires already in poles for lighting and avoid any interference.

### Exterior Events

- No permanently installed large scale event production system
- Need to understand what electrical connections at the event stage will likely be needed to reduce chords going back to the building for vendor provided sound systems at stage.
- Need to understand what electrical / AV connections may be needed at stage for any PA system (stand-alone)

- Need to understand lighting at stage for events from CITY team. Will there be permanent lighting or just temporary or BOTH?

#### Park Routing of wire / systems

- Confirm Low voltage conduits in current 90% Park CD plans for Phase 3 are enough to support Audio / Wi-Fi / CCTV as shown or if an increase / separate conduits are needed for any reason.
- Confirm run lengths will be supported as shown without any voltage / quality of sound / quality of signal “drop”
- Work to reduce the number of hand-holes and access areas in the park planting and paving areas with landscape architect.

#### Controls

##### Building / Park

- All controls in the building and park need to be in a central room inside the building. Phase 1 / 2 lighting and low voltage conduit needs to home run to the building and be relocated during Phase 3 of the project construction from the existing restroom structure (remained in place for Phase 1 / 2) to the new building.

## TASK 1: HERITAGE PARK – PHASE 3 BID DOCUMENTATION

---

### Description:

The Avidex effort for Task 1 will be to review and advise the design team on Phase 3 Heritage Park issues that pertain – directly or indirectly - to the City- defined AV scope of work for the Park, in order to ensure that the needs of the AV systems are supported on the bid documents for fulfillment through all elements of the project build. Consistent with this, Avidex will work with the City and the Design Team to refine and elaborate the definition of the AV scope of work in Heritage Park to ensure the range of use-cases is understood, defined and accommodated.

### Activities:

Phase 3 specific Avidex tasks will include the following:

1. Project discovery and needs analysis
2. Consultation with third parties as needed (i.e., manufacturers, service providers)
3. Virtual Meetings with the City, Architect and Electrical Consultant
4. AV solution research
5. AV System conceptual drawing development
6. Design Team document review; redline as necessary
7. General communications (RFI responses) and administration
8. Submittals and document management

### Meeting Schedule

Avidex has budgeted the following proposed meeting schedule for participation in this phase of the project scope of work:

1. Two (2) virtual meetings with the Electrical Consultant
2. Two (2) virtual meeting with the City of Sumner
3. One (1) virtual meeting with the project Architect/Design Team
4. One (1) in-person meeting as needed with project stakeholders/Design Team

### Deliverables

Avidex will deliver the following materials, consistent with supporting the AV scope of work within the fulfillment of the project objectives for Phase 3.

1. Needs Analysis Report for Heritage Park AV scope of work (with one [1] revision)

2. Programming Report and Estimate of Probable Cast for Heritage Park AV scope of work (with one [1] revision)
3. Avidex will issue a formal document acknowledging review of project bid documents and acknowledgement of Phase 3 Architectural and MEP documents compatibility with AV Scope of Work.
- 3.1 NOTE: Deliverable #3 assumes timely (one-week) access to project documents; drawings and specifications in legible form; suitable for annotation and comment.

**TASK 2: HERITAGE PARK EVENT BUILDING – PHASE 4 BID DOCUMENTS**

---

## **2.1 - 100% Construction | Permit | Bid Plans**

### **Description:**

The Avidex effort for Task 2.1 will be to review and advise the design team on Phase 4 Heritage Park Building issues that pertain – directly or indirectly - to the City- defined AV scope of work. The objective being to ensure that the needs of the AV systems are supported on the bid documents for fulfillment through all elements of the project build. Consistent with this, Avidex will work with the City and the Design Team to refine and elaborate the definition of the AV scope of work in the Heritage Park Building to ensure the range of use-cases is understood, defined and accommodated.

### **Activities:**

Phase 4, task 2.1 specific Avidex tasks will include the following:

1. Project discovery and needs analysis
2. Consultation with third parties as needed (i.e., manufacturers, service providers)
3. Virtual Meetings with the City, Architect and Electrical Consultant (as enumerated below)
4. AV solution research
5. AV System conceptual drawing development
6. Design Team document review; redline as necessary
7. General communications (RFI responses) and administration
8. Submittals and document management

### **Meeting Schedule**

Avidex has budgeted the following proposed meeting schedule for task 2.1 of phase 4 of the project scope of work:

1. Two (2) virtual meetings with the Electrical Consultant
2. One (1) virtual meeting with the City of Sumner
3. One (1) virtual meeting with the project Architect/Design Team
4. One (1) in-person meeting with the City of Sumner stakeholders to review proposed scope of work and to conduct an audit of existing AV system components to determine their suitability of re-purposing to the new facilities.

### **Deliverables**

Avidex will deliver the following materials, consistent with supporting the AV scope of work within the fulfillment of the project objectives for Phase 4, task 2.1.

1. Needs Analysis Report for Phase 4 Heritage Park Building AV scope of work (with one [1] revision)
  2. Avidex will issue a formal document acknowledging review of project bid documents and acknowledgement of Phase 4 Architectural and MEP documents compatibility with AV Scope of Work.
- 2.1 NOTE: Deliverable #2 assumes timely (one-week) access to project documents; drawings and specifications in legible form; suitable for annotation and comment.

## **(2.2) - Bid Specifications (HPEB)**

### **Description:**

The Avidex effort for Task 2.2 will be to review and advise the design team on Phase 4 Heritage Park Building issues that pertain – directly or indirectly - to the City- defined AV scope of work. The objective being to ensure that the needs of the AV systems are supported on the bid documents for fulfillment through all elements of the project build. Consistent with this, Avidex will work with the City and the Design Team to refine and elaborate the definition of the AV scope of work in the Heritage Park Building to ensure the range of use-cases is understood, defined and accommodated.

### **Activities:**

Phase 4, task 2.2 specific Avidex activities will include the following:

1. Virtual Meetings with the City, Architect and Electrical Consultant (as enumerated below)
2. In-person meetings
3. Consultation with third parties as needed (i.e., manufacturers, service providers)
4. AV solution research and consultation
5. AV System conceptual drawing development
6. Design Team document review; redline as necessary
7. General communications (RFI responses) and administration
8. Submittals and document management

## **Meeting Schedule**

Avidex has budgeted the following proposed meeting schedule for participation in the Phase 4, task 2.2 of the project scope of work:

1. One (1) virtual meeting with the Electrical Consultant
2. Two (2) virtual meetings with the City of Sumner
3. One (1) virtual meeting with the project Architect/Design Team
4. One (1) in-person meeting as needed with project stakeholders/Architect/Design Team
5. One (1) in-person meeting with the City of Sumner stakeholders for presentation and review of final Programming Report

## **Deliverables**

Avidex will perform the following review and comment, consistent with supporting the AV scope of work within the fulfillment of the project objectives for Phase 4, task 2.2.

1. Programming Report and Estimate of Probable Cost for Phase 4 Heritage Park Building AV scope of work (with one [1] revision)
2. Avidex will issue a formal document acknowledging review of project bid specifications and acknowledgement of Phase 4 Architectural and MEP documents compatibility with AV Scope of Work.  
2.1 NOTE: Deliverable #2 assumes timely (one-week) access to project documents; drawings and specifications in legible form; suitable for annotation and comment.

## **2.3 Advanced Building Renderings**

### **Description**

Avidex anticipates no activity specific to this phase of the project work. And has not budgeted any amount of time or effort to this activity which we assume to be the responsibility of others.

## COMMENTS, ASSUMPTIONS, EXCEPTIONS & EXCLUSIONS

---

1. Avidex assumes that it will have access and participation rights in the Design Teams communication platforms in order to expedite and facilitate the free flow of information, documents and files with project disciplines and stakeholders.
2. Avidex understands that there will be no requirement for the production of Division 27 Audio-Visual scope of work bid documents.
3. Avidex will annotate project drawing files received from the Architect and design team in PDF format. Avidex comments, annotations and redlines will be applied, typically in Bluebeam, as deemed necessary, and returned to the design team for incorporation into the project documentation.
4. Avidex understands that it will not be producing or contributing content - text or drawings - for inclusion in the Phase 3 or Phase 4 Permit or Construction document sets.
5. Additional project tasks and scope of work not specifically referenced in this document may require additional time, not currently budgeted. If this occurs, Avidex will obtain approval in advance for added cost that would attach to continued work.
6. The Avidex scope of work (i.e., to lay the groundwork for a successful AV system deployment) does not precisely align with the general construction project definitions of Tasks 1, 2.1, 2.2 and 2.3. However, every effort has been made to allocate blocks of time deemed appropriate and in sequence to these defined project milestones.

## KEY PERSONNEL

---

Name	Role
<i>Dave Crace</i>	<i>Account Executive</i>
<i>Stan Holt</i>	<i>Audiovisual Design Engineer</i>

**PRICE AND PAYMENT SCHEDULE**

---

AVIDEX TASK 1, PH 3, DESIGN & TECH SERVICES	\$15,385.81
AVIDEX TASK 2.1, PH 4, DOCUMENT DESIGN & TECH SERVICES	\$23,499.77
AVIDEX TASK 2.2, PH 4, SPECIFICATION DESIGN & TECH SERVICES	\$13,114.42
AVIDEX TASK 2.3, PH 4, ADVANCED BUILDING RENDERINGS	\$0.00
AVIDEX TOTAL, DESIGN & TECHNICAL SERVICES	\$52,000.00
Senior Design Engineer, hourly rate:	\$165.00
Project Manager, hourly rate:	\$140.00
CAD Drawing Service: hourly rate:	\$120.00

*\*Includes travel.*

**PAYMENT TERMS**

---

1. Monthly progress invoices will be issued with net 30-day terms.
2. Sales tax to be added at the time of invoice.

**AUTHORIZATION TO PROCEED – DESIGN SERVICES**

---

Avidex will begin the design phase of this project upon receipt of the client purchase order or executed contract referring to this proposal and the mobilization fee.

Submitted by: Avidex Industries, LLC

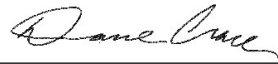
Name: Dave Crace Signature:   
Date: April 13, 2026

Client Approval

Name: \_\_\_\_\_ Signature: \_\_\_\_\_  
Date: \_\_\_\_\_

---

**SUBJECT:** Ordinance No. 2967 - System Development Charges Calculation

**CATEGORY:** Ordinance

---

**BUDGET IMPACT:**

Expenditure Required: None

Within Budget Allocation: N/A

---

**ATTACHMENTS:**

1. Ordinance No. 2967 - System Development Amendments

**STAFF CONTACT:** Doug Beagle, Development Services Director

---

**SUMMARY BACKGROUND:**

The City's sewer utility calculates and assesses, based on a use type, an impact fee (also known as a System Development Charge) based on the proposed new use of a structure or when an applicant proposes a change of use. Ordinance No. 2967 allows for the difference in impact fees charged to be based on what the current use would be charged under the current fee system instead of what had been charged historically. Therefore, it may result in a lower fee for the change of use for a new business than without this change. This amendment has the potential to benefit longstanding uses and the conversion of these businesses/buildings into new businesses.

---

**COUNCIL COMMITTEE/STUDY SESSION:** Community Development Committee

**MEETING/STUDY SESSION DATE:** 4/22/2026

**COMMITTEE RECOMMENDATION:** Do Pass

**STAFF RECOMMENDATIONS/MOTION:**

Move to adopt Ordinance No. 2967, amending sections of Chapter 13.16, of the Sumner Municipal Code addressing System Development Charges.

ORDINANCE NO. 2967  
CITY OF SUMNER, WASHINGTON

AN ORDINANCE OF THE CITY COUNCIL OF THE CITY OF SUMNER, WASHINGTON, AMENDING SMC 13.16 RELATED TO THE CALCULATION OF SYSTEM DEVELOPMENT CHARGES FOR CHANGES OF USE.

**WHEREAS**, the City’s sewer utility calculates and assesses, based on a use type, an impact fee (also known as system development charges) based on the proposed new use of a structure when an applicant proposes to change the use; and

**WHEREAS**, for some permit applications that propose a change of use to a long-standing historical use type that preexisted the current SDC fee calculations or for uses that do not have an appropriately documented utility support for the currently-billed ERUs (Equivalent Residential Units), it can be difficult if not impossible to appropriately assess new SDCs; and

**WHEREAS**, there are several instances, during a change of use permit review, where the current ERUs assessed to a particular city utility account do not adequately reflect the actual use, and thus the impact on the utility(ies) that should have applied; and

**WHEREAS**, in an effort to more reasonably account for the true impact to the City’s utility systems during a change of use that is without recent or justified documentation on the ERU calculations, the City finds that it is appropriate to credit the account consistent with any appropriately justified historic or properly permitted building use, if such use can be proven, in writing, to have been in operation for at least the ten years prior to the date of the change of use application; and

**WHEREAS**, the Community Development Committee reviewed these amendments on April 22, 2026 and recommended a do pass.

**NOW, THEREFORE, THE CITY COUNCIL OF THE CITY OF SUMNER, WASHINGTON, DO ORDAIN AS FOLLOWS:**

**Section 1.** Sumner Municipal Code Section 13.16.030, titled “Definitions” is hereby amended as follows:

...

**Z. Historic Impact.**

For purposes of system development charge (SDC) calculations, “Historic Impact” means the existing ERU credit assigned to a property. The ERU credit shall be based on the current or most recent legally permitted use as verified by retained City records; however, if such records are unavailable or insufficient, the City may determine the ERU credit based on a prior use of the property if the applicant provides written documentation demonstrating that the use has been in continuous operation for at least ten (10) years prior to the application.

The sufficiency of such documentation and the resulting ERU credit determination shall be made by the Development Services Director or designee.

**Section 2.** Sumner Municipal Code Section 13.16.220 “System Development Charges” is hereby amended as follows:

...

**E. ERU Change of Use Calculation.** A permit that proposes a change of use of a property will be given an ERU credit for the Historic Impact as defined in 13.16.030(Z) for that property to be applied towards the resulting system development charge.

**Section 3. Severability.** If a section, subsection, paragraph, sentence, clause, or phrase of this ordinance is declared unconstitutional or invalid for any reason by any court of competent jurisdiction, such decision shall not affect the validity off the remaining portions of this ordinance. If the provisions of this ordinance are found to be inconsistent with other provisions of the Sumner Municipal Code, this ordinance is deemed to control.

**Section 4. Effective Date.** This ordinance shall be effective five (5) days from and after its passage approval and publication as provided by law.

**Section 5. Corrections by City Clerk or Code Reviser.** Upon approval of the city attorney, the city clerk and the code reviser are authorized to make necessary corrections to this ordinance, including the correction of clerical errors; ordinance, section, or subsection number; or references to other local, state, or federal laws, codes, rules, or regulations.

**Section 6. Implementation.** The Mayor is hereby authorized to implement such administrative procedures as may be necessary to carry out the directions of this legislation.

Passed by the City Council and approved by the Mayor the of the City of Sumner, Washington, at a regular meeting thereof this \_\_\_\_\_ day of \_\_\_\_\_, 2026.

\_\_\_\_\_  
Mayor Carla S. Bowman

**ATTEST:**

**APPROVED AS TO FORM:**

\_\_\_\_\_  
Michelle Converse, CMC, City Clerk

\_\_\_\_\_  
Andrea Marquez, City Attorney

*Date Adopted:* XXX XX, 2026  
*Date of Publication:* XX XX, 2026 Online / XX ZZ, 2026  
*Effective Date:* XX, XX, 2026